

**RATIOMETRIC MEASUREMENT  
 (Analog Division)**

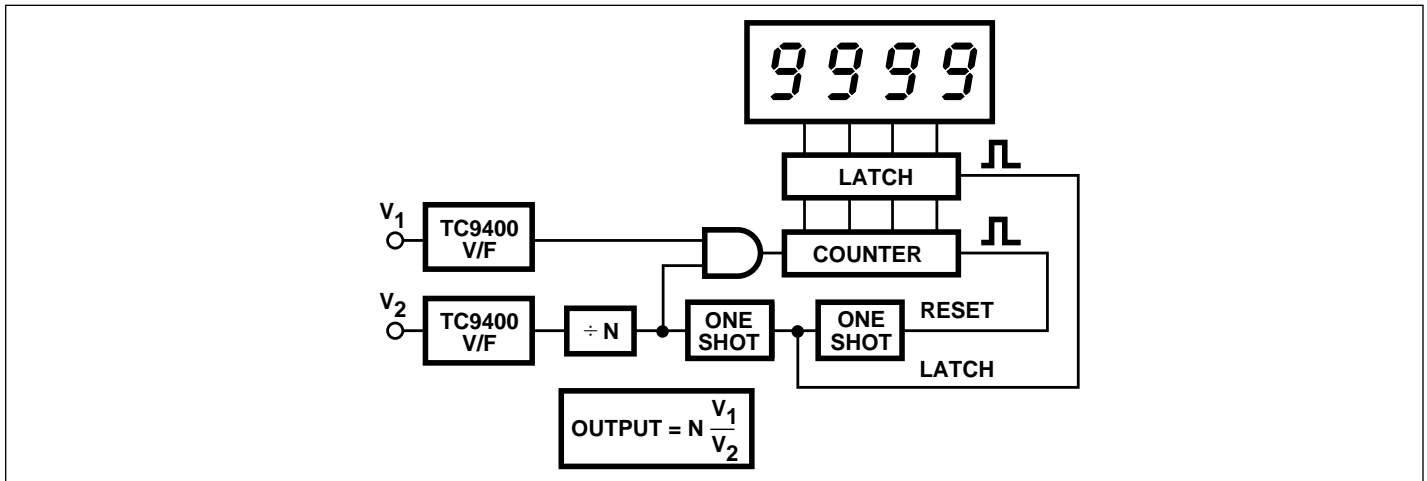

One of the most difficult circuits to build is one which will divide one analog signal by another. Two voltage-to-frequency (V/F) converters can do such division with ease.

The numerator is counted directly as a signal, while the denominator forms the time base.

**RPM/SPEED INDICATOR**

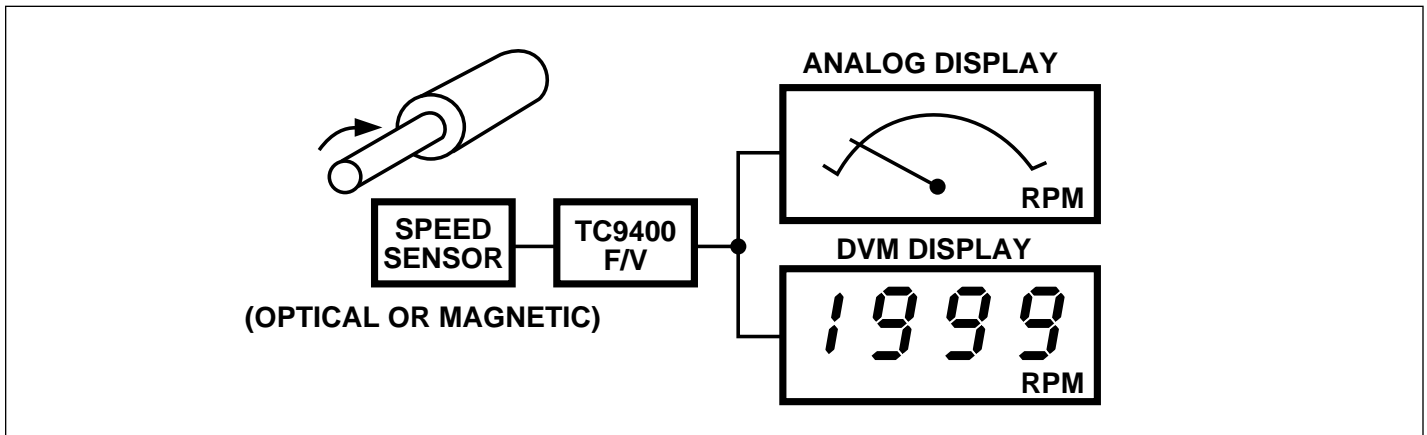

Flow rates and revolutions per second are nothing more than frequency signals, since they measure the number of events per time period. Optical and magnetic sensors will convert these flows and revolutions into a digital

signal which, in turn, can be converted to a proportional voltage by the use of a frequency-to-voltage (F/V) converter. A simple voltmeter will then give a visual indication of the speed.

# APPLICATIONS OF THE TC9400 VOLTAGE-TO-FREQUENCY/ FREQUENCY-TO-VOLTAGE CONVERTER

AN-10

## MOTOR SPEED CONTROL

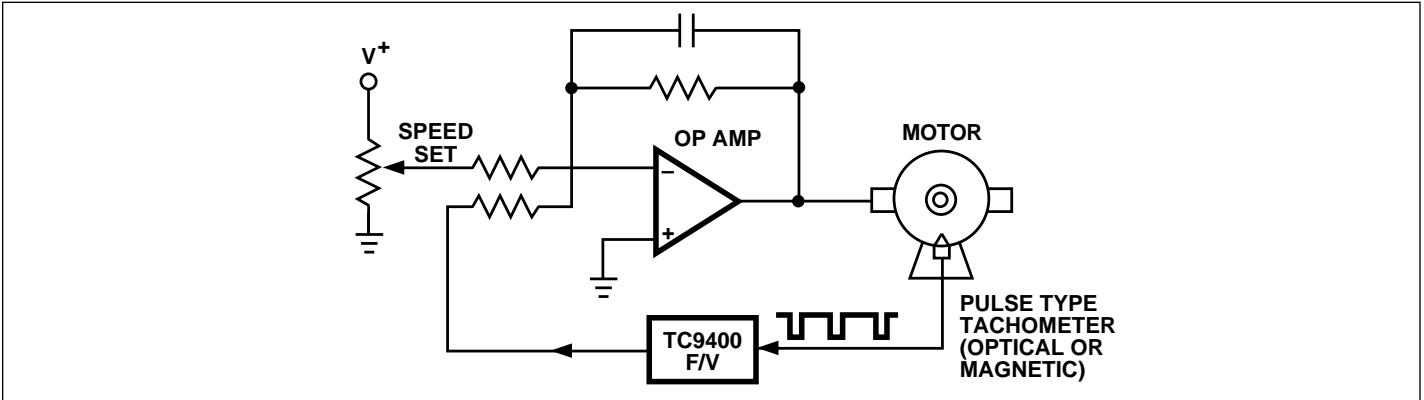

The motor's speed is measured with the F/V converter, which converts RPM into a proportional voltage. This volt-

age is used in a negative feedback system to maintain the motor at the controlled setting.

## PROPORTIONAL FLOW-RATE CONTROLLER

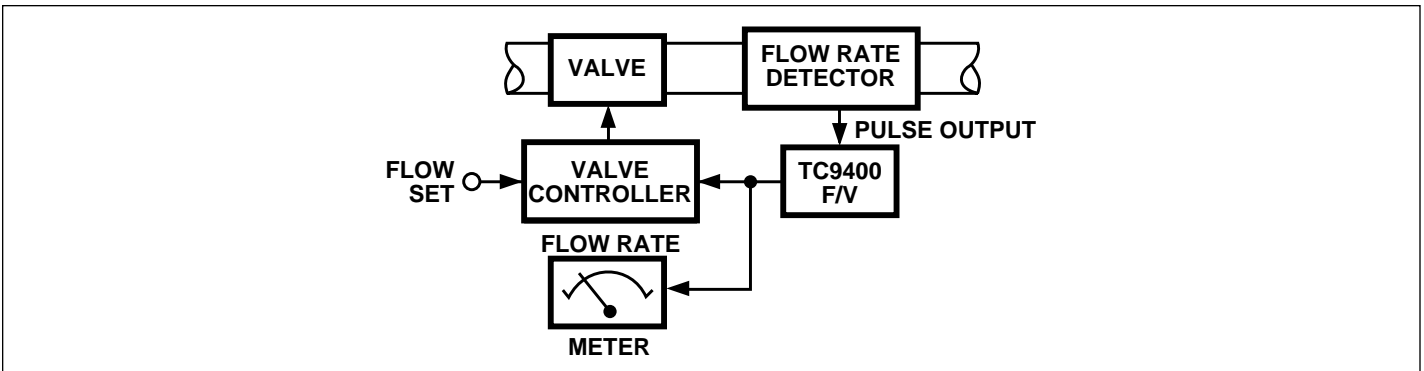

A TC9400 F/V converter can be used to regulate the amount of liquid or gas flowing through a pipeline.

The flow-rate detector generates a pulse train whose frequency is proportional to the rate of flow through it. The F/V converts this frequency to a proportional analog volt-

age which is used to drive the valve controller. The valve controller regulates the valve so that the flow is steady, even though pipeline pressure goes up and down. A voltmeter connected to the F/V converter output will indicate the actual instantaneous flow rate.

# APPLICATIONS OF THE TC9400 VOLTAGE-TO-FREQUENCY/ FREQUENCY-TO-VOLTAGE CONVERTER

AN-10

## TEMPERATURE METER

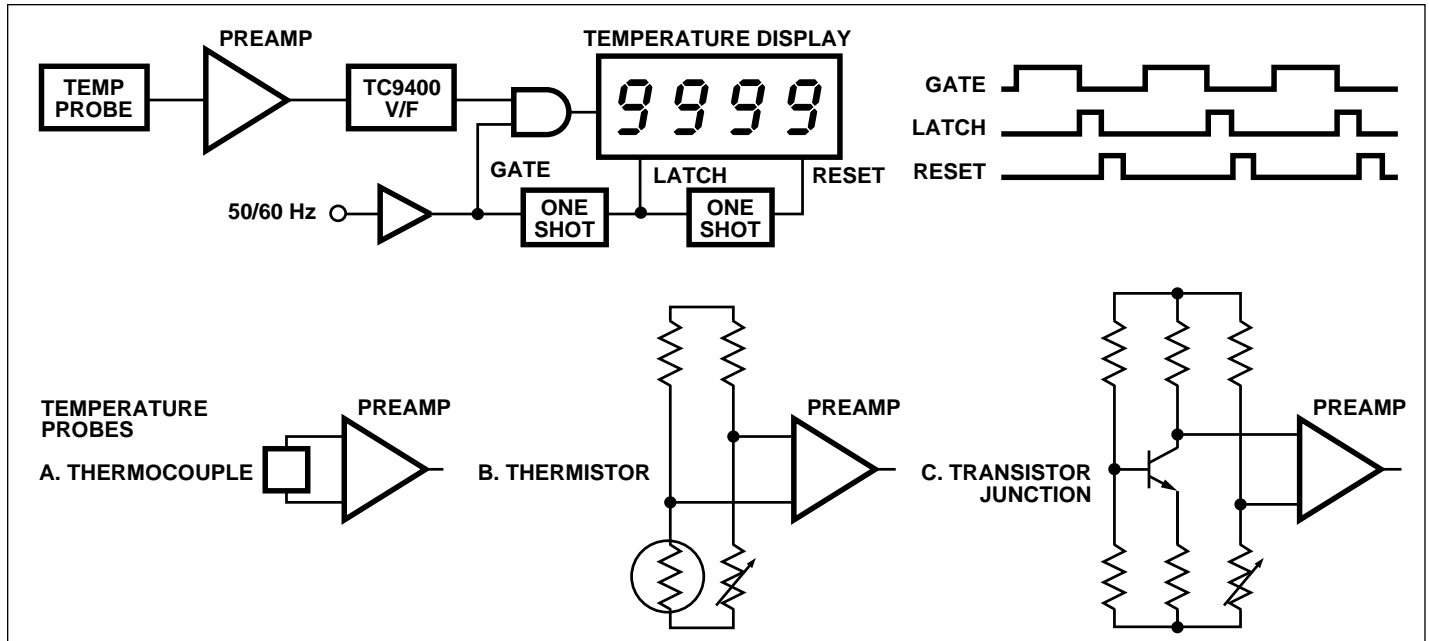

A temperature meter using the voltage output of a probe, such as one of the three shown, can be economically and straightforwardly implemented with the TC9400 V/F converter. The V/F output is simply counted to display the temperature.

For long-distance data transmission, the TC9400 can be used to modulate an RF transmitter.

## A/D CONVERSION WITH A MICROPROCESSOR

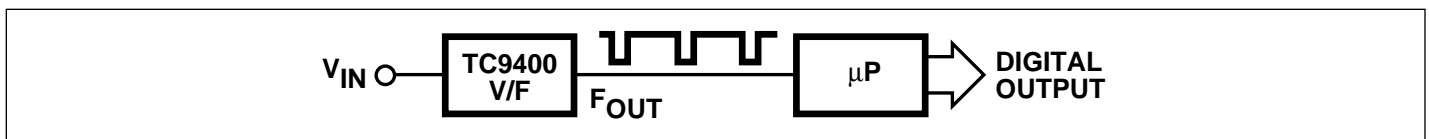

There are two schemes that can be utilized to accomplish A/D conversion with a microprocessor:

- (1) Depending on the number of digits of resolution required,  $V_{OUT}$  is measured by counting the V/F converter's frequency for 1 ms, 10 ms, 100 ms, or 1 second. The final count is then directly proportional to the input voltage. (The microprocessor provides the time base.)
- (2)  $V_{IN}$  is measured by determining the time between two pulses (negative edges). The  $F_{OUT}$  signal is used as a

gate for counting the microprocessor's clock. The final count will then be inversely proportional to the input signal.

By taking the one's complement (changing 1's to 0's and 0's to 1's) of the final binary count, a value directly proportional to the input will result.

This technique will give a faster conversion time when resolution is very important, but dynamic range is limited.

# APPLICATIONS OF THE TC9400 VOLTAGE-TO-FREQUENCY/ FREQUENCY-TO-VOLTAGE CONVERTER

AN-10

## 13-BIT A/D CONVERTER

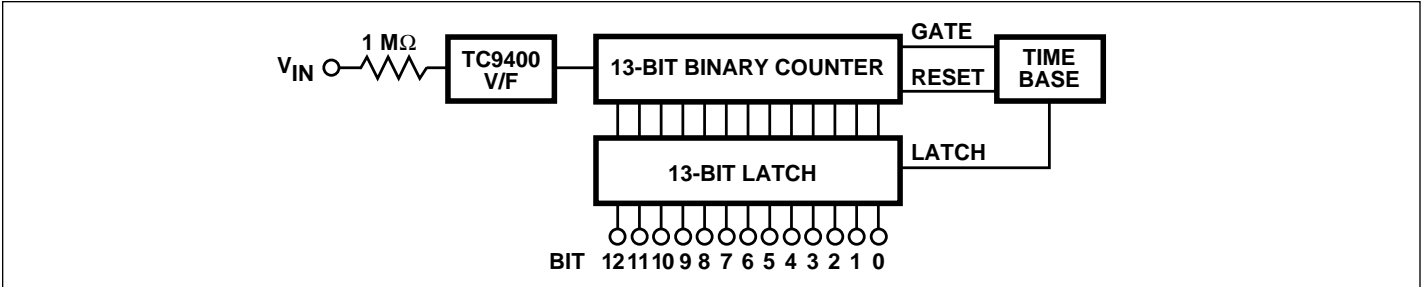

A 13-bit binary or 4-digit BCD A/D converter can be built by combining the TC9400 V/F converter with a counter, latch, and time base. When the V/F converter is set up for

10 kHz full scale, a 1-second time base will provide one conversion per second.

## 4-DIGIT VOLTMETER WITH OPTOISOLATED INPUT

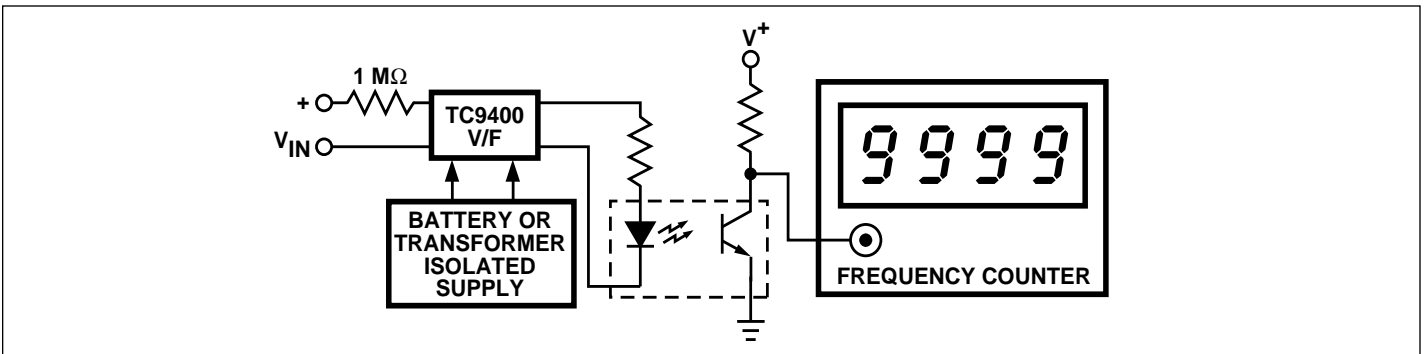

The use of a frequency counter will give a display of the V/F converter's frequency, which is directly proportional to the input voltage.

When the V/F converter is running at 10 kHz full scale, a 0.1-second time base will give 3-digit resolution with 10 readings per second.

The optoisolator is used for transmitting the frequency, so there is no DC path to the frequency counter. This is especially useful in medical applications, where a voltage probe should not be directly connected to the human body.

## LONG-TERM INTEGRATOR WITH INFINITE HOLD

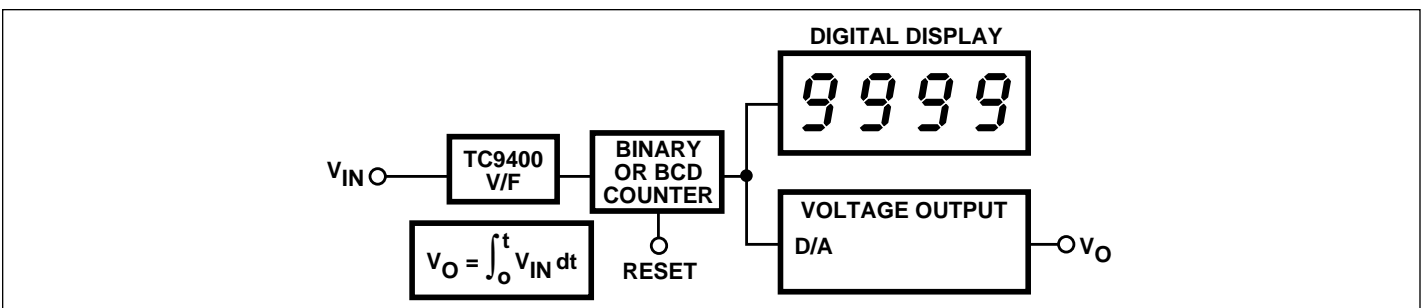

This system will integrate an input signal for minutes or days, and hold its output indefinitely. The data is held in a digital counter and stays there until the counter is reset.

Typical applications involve controlling the amount of surface metal deposited in a plating system or how much charge a battery has taken on.

# APPLICATIONS OF THE TC9400 VOLTAGE-TO-FREQUENCY/ FREQUENCY-TO-VOLTAGE CONVERTER

AN-10

## LONG-TERM INTEGRATOR FOR BIPOLAR ( $\pm$ ) SIGNALS

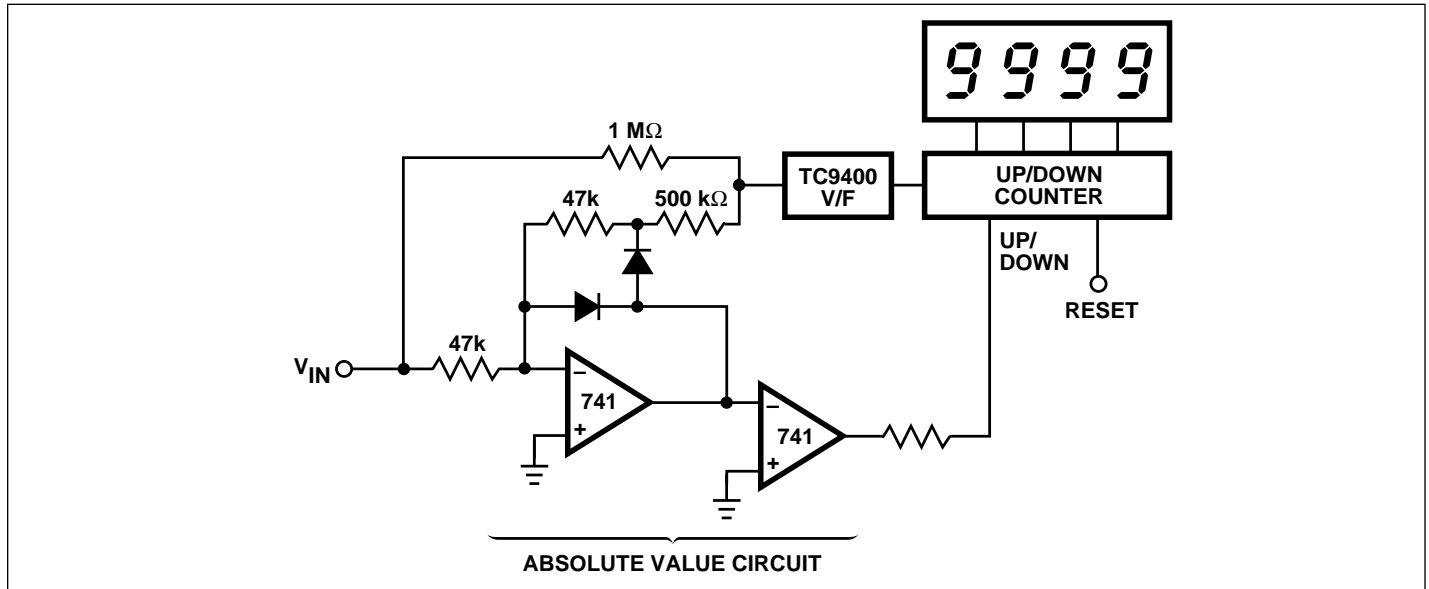

When the input signal is negative as well as positive, there has to be way of generating "negative" frequencies. An absolute value circuit accomplishes this by giving the

V/F converter a positive voltage only; and also telling the counter to count up for a positive voltage and to count down for a negative voltage.

## ANALOG SIGNAL TRANSMISSION OVER TELEPHONE LINES

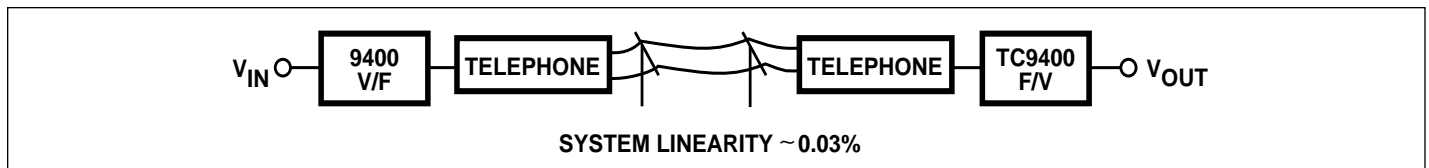

The TC9400's square-wave output is ideal for transmitting analog data over telephone lines. A square wave is actually preferred over a pulse waveform for data transmission, since the square wave takes up less frequency spectrum.

The square wave's spectrum can be further reduced by use of low-pass filters.

At the other end of the telephone line, the TC9400 converts the frequency signal back into a voltage output linearly proportional to the original input voltage.

# APPLICATIONS OF THE TC9400 VOLTAGE-TO-FREQUENCY/ FREQUENCY-TO-VOLTAGE CONVERTER

AN-10

## TELEMETRY

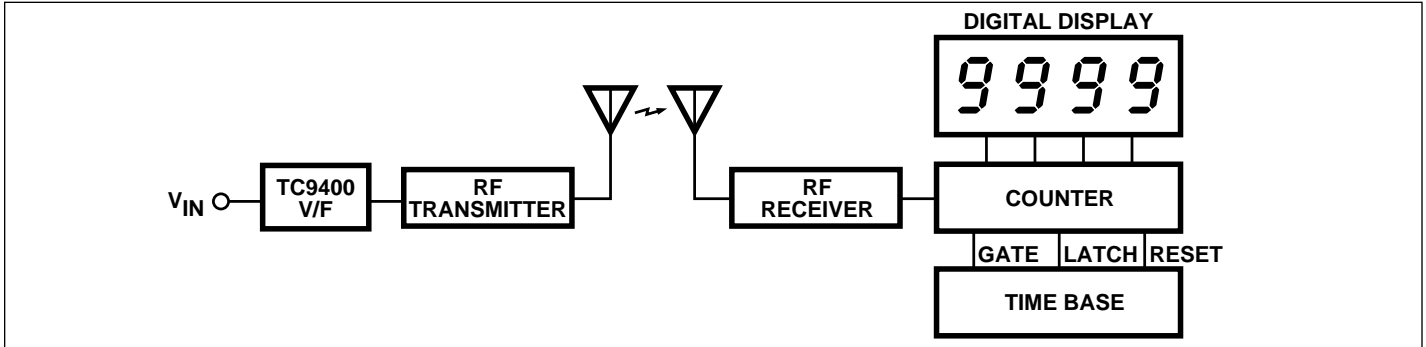

In a telemetry system, the TC9400 converts the analog input ( $V_{IN}$ ) into frequencies (10 Hz to 100 kHz) which can be used to modulate an RF transmitter.

At the other end, a receiver picks up the RF signal and modulates it back into the 10 Hz to 100 kHz spectrum. A frequency counter connected to this signal then gives a

count linearly proportional to the original analog voltage ( $V_{IN}$ ).

If a linearly-proportional analog output voltage is required, the counter can be replaced by a TC9400 used in the F/V mode.

## HIGH NOISE IMMUNITY DATA TRANSMISSION

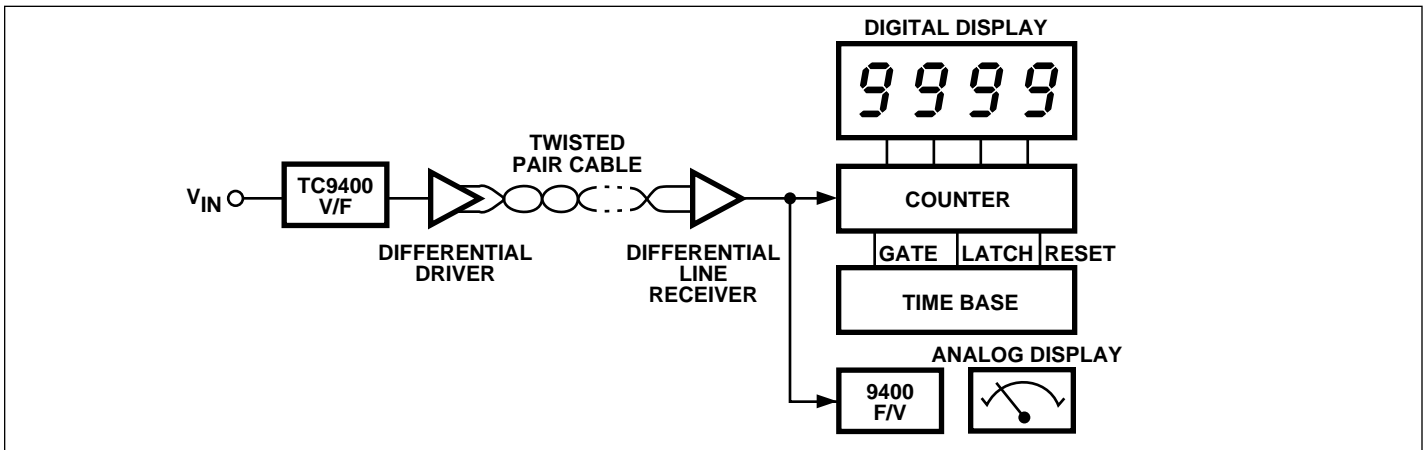

When transmitting analog data over long distances, it is advantageous to convert the analog signal into a digital signal, which is less susceptible to noise pick-up.

In the system shown above, the TC9400 converts the input voltage into a pulse or square wave which is trans-

mitted on a pair of wires by use of a line driver and receiver. At the other end, the original voltage ( $V_{IN}$ ), can be digitally displayed on a frequency counter or converted back to analog voltage by use of a TC9400 F/V converter.

## DC RESPONSE DATA RECORDING SYSTEM

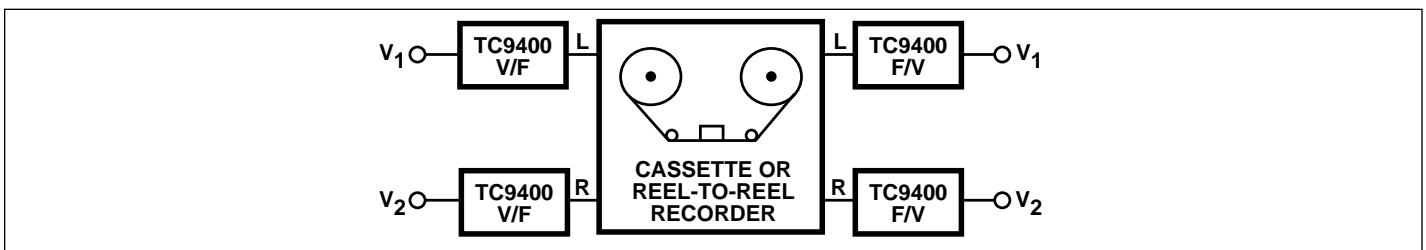

Low-frequency analog data (DC to 10 kHz) can be recorded anywhere, stored, and then reproduced. By vary-

ing the playback speed, the frequency spectrum of the original data can be shifted up or down.

# APPLICATIONS OF THE TC9400 VOLTAGE-TO-FREQUENCY/ FREQUENCY-TO-VOLTAGE CONVERTER

AN-10

## FREQUENCY SHIFT KEYING (FSK) GENERATION AND DECODING

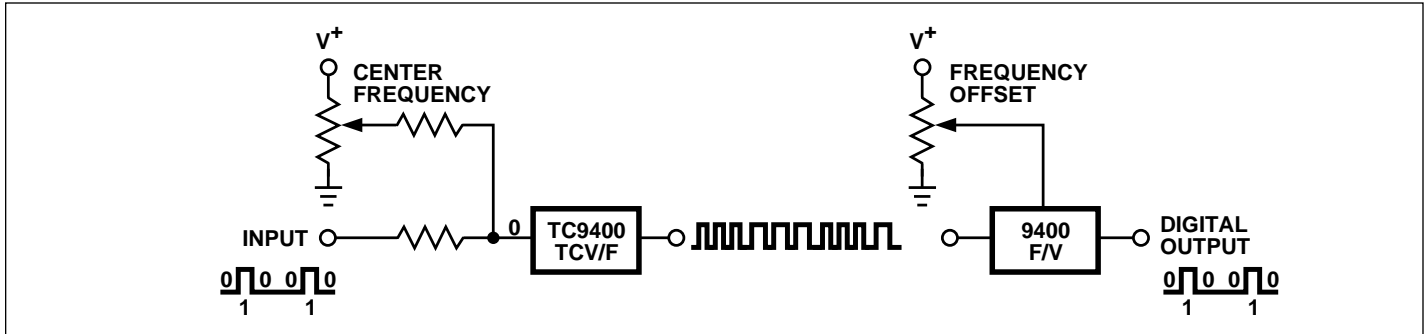

Frequency shift keying (FSK) is a simple means of transmitting digital data over a signal path (two wires, telephone lines, AM or FM transmitters).

Typically, only two frequencies are transmitted. One corresponds to a logical "0," the other to a logical "1".

A TC9400 V/F converter will generate these two frequencies when connected as shown above. The

potentiometer sets the V/F converter to the lower frequency. The digital input then determines which frequency is selected. A "0" selects the lower frequency, a "1" selects the upper frequency.

The digital frequency signal is converted back into a digital format by a TC9400 used in the F/V mode.

## ULTRALINEAR FREQUENCY MODULATOR

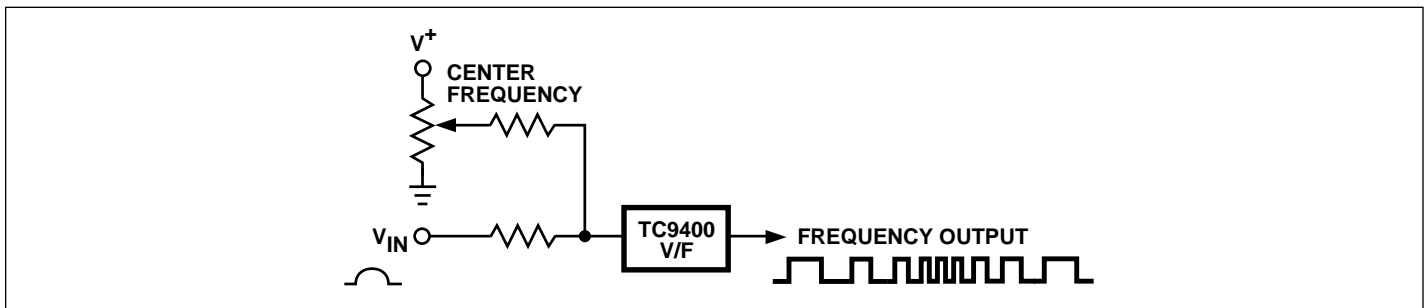

Since the TC9400 is a very linear V/F converter, an FM modulator is very easy to build.

The potentiometer determines the center frequency, while  $V_{IN}$  determines the amount of modulation (FM

deviation) around the center frequency.  $V_{IN}$  can be negative as well as positive.

## FREQUENCY METER

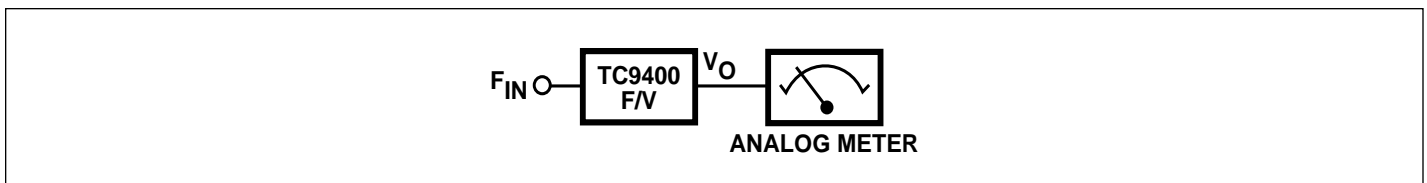

The TC9400 will convert any frequency below 100 kHz into an output voltage, which is linearly proportional to the input frequency. The equivalent frequency is then displayed on an analog meter.

If the incoming frequency is above 100 kHz, a frequency divider in front of the TC9400 can be used to scale the frequency down to the 100 kHz region.

# APPLICATIONS OF THE TC9400 VOLTAGE-TO-FREQUENCY/ FREQUENCY-TO-VOLTAGE CONVERTER

AN-10

## TACHOMETER BAR-GRAPH DISPLAY

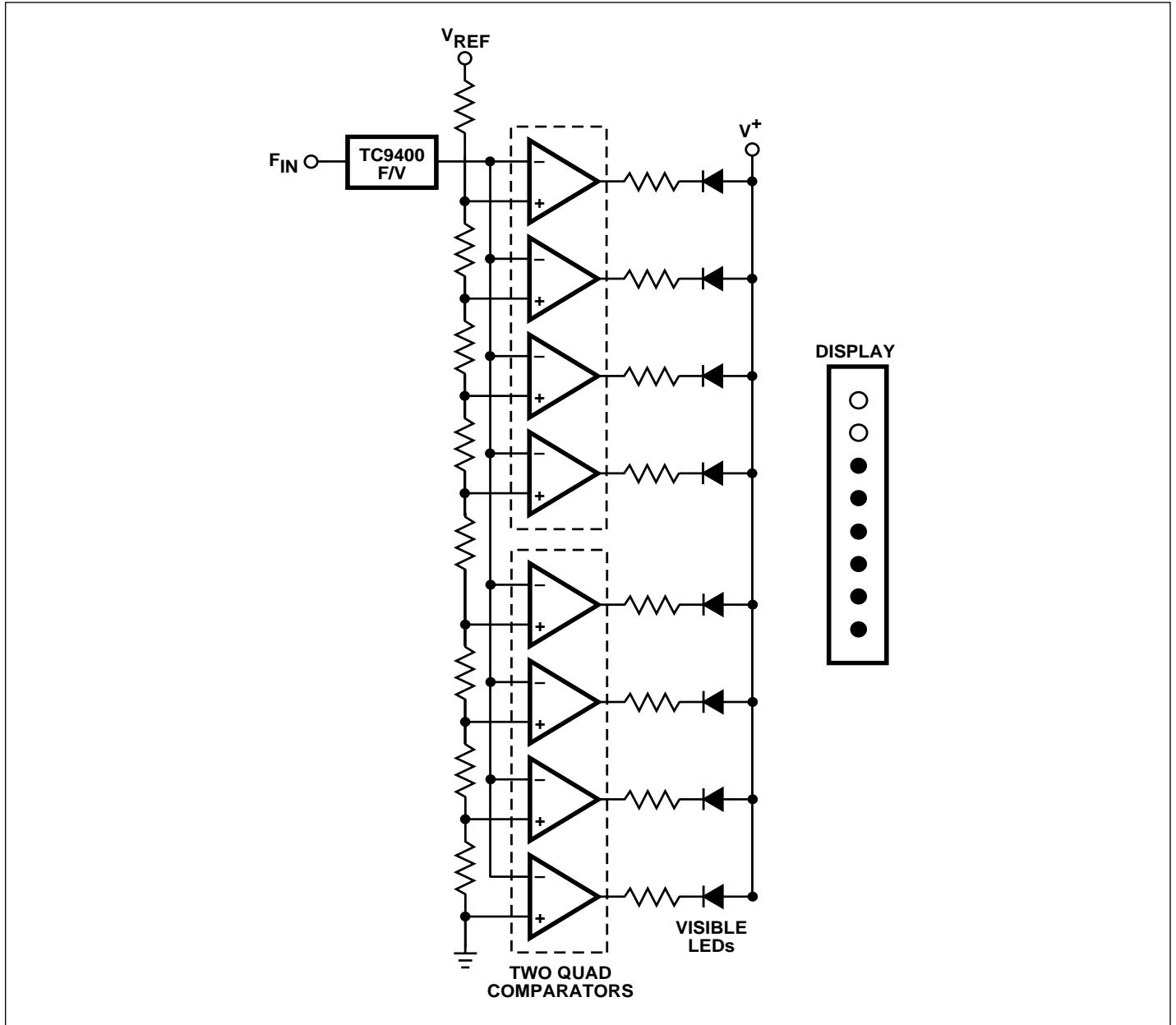

A tachometer can be constructed by using the TC9400 in the F/V mode to convert the frequency information (RPM) into a linearly-proportional voltage. This voltage is then compared to one of "n" comparators (8 in this example). When the voltage exceeds the trip point of a

comparator, the respective LED lights up and will continue to stay lit as long as the voltage exceeds the trip point. This gives a bar-graph-type display, with the height of the bar being proportional to RPM.

# APPLICATIONS OF THE TC9400 VOLTAGE-TO-FREQUENCY/ FREQUENCY-TO-VOLTAGE CONVERTER

AN-10

## FREQUENCY/TONE DECODER

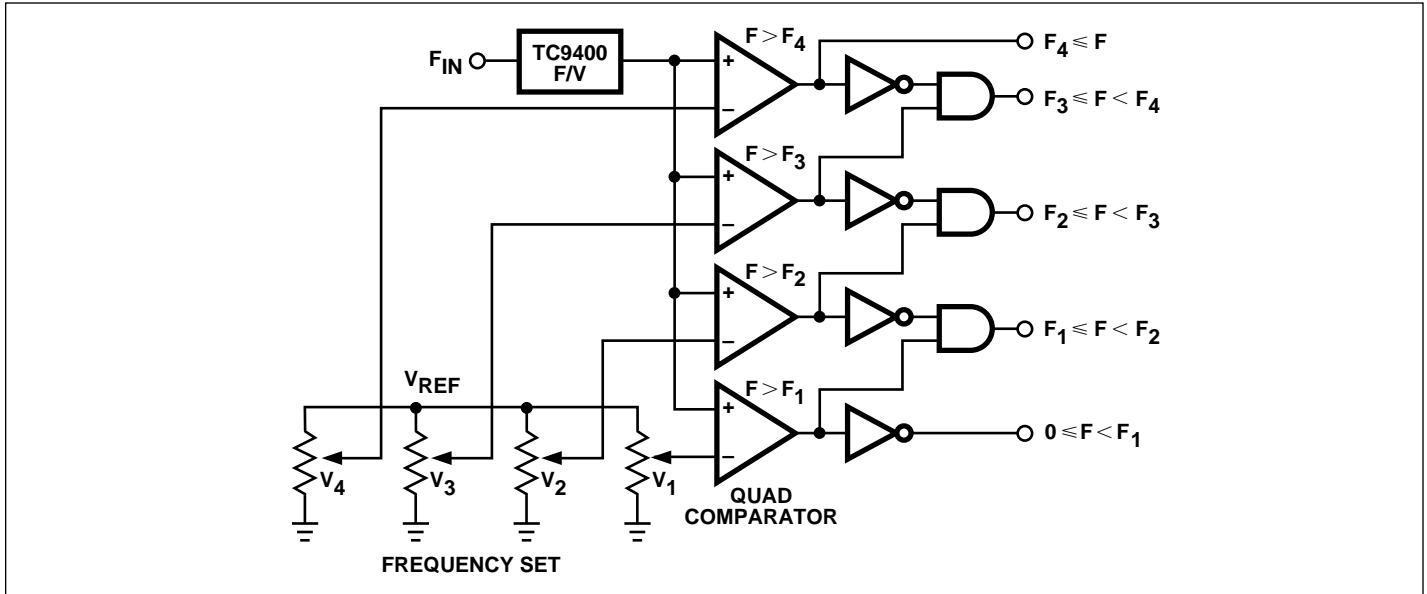

The frequency, or tone, to be detected is converted into a proportional analog voltage by the TC9400 F/V converter. The quad comparators sense when the voltage (frequency) exceeds any of the four preset frequency limits. A logical "1" at any of the five outputs indicates the frequency is within those limits.

This system is useful for determining which frequency band a signal is in, or for remote control, where each frequency band corresponds to a different command.

## FM DEMODULATION WITH A PHASE-LOCKED LOOP

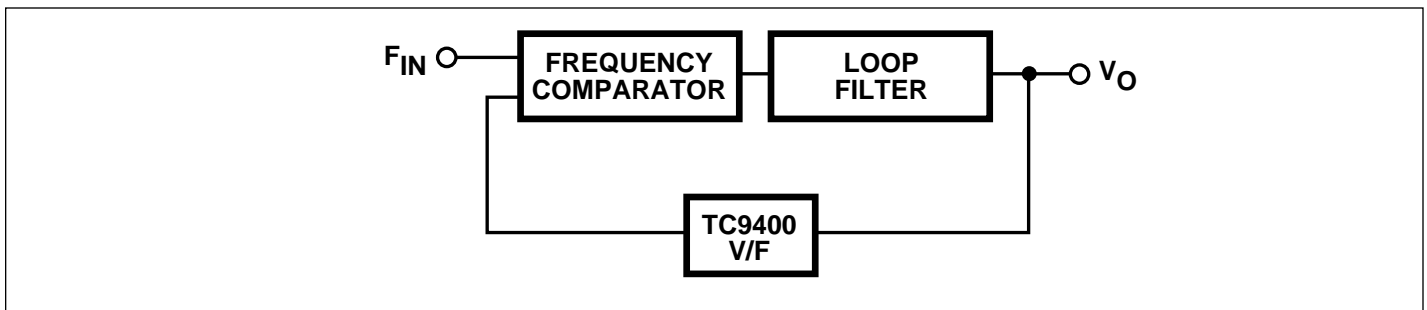

The high linearity of the TC9400 (0.01%) is used to greatly improve the performance of a phase-locked loop, resulting in very precise tracking of  $V_O$  with respect to  $F_{IN}$ .

# APPLICATIONS OF THE TC9400 VOLTAGE-TO-FREQUENCY/ FREQUENCY-TO-VOLTAGE CONVERTER

AN-10

## ANALOG DATA TRANSMISSION ON DC SUPPLY LINES (Two-Wire Transmitter)

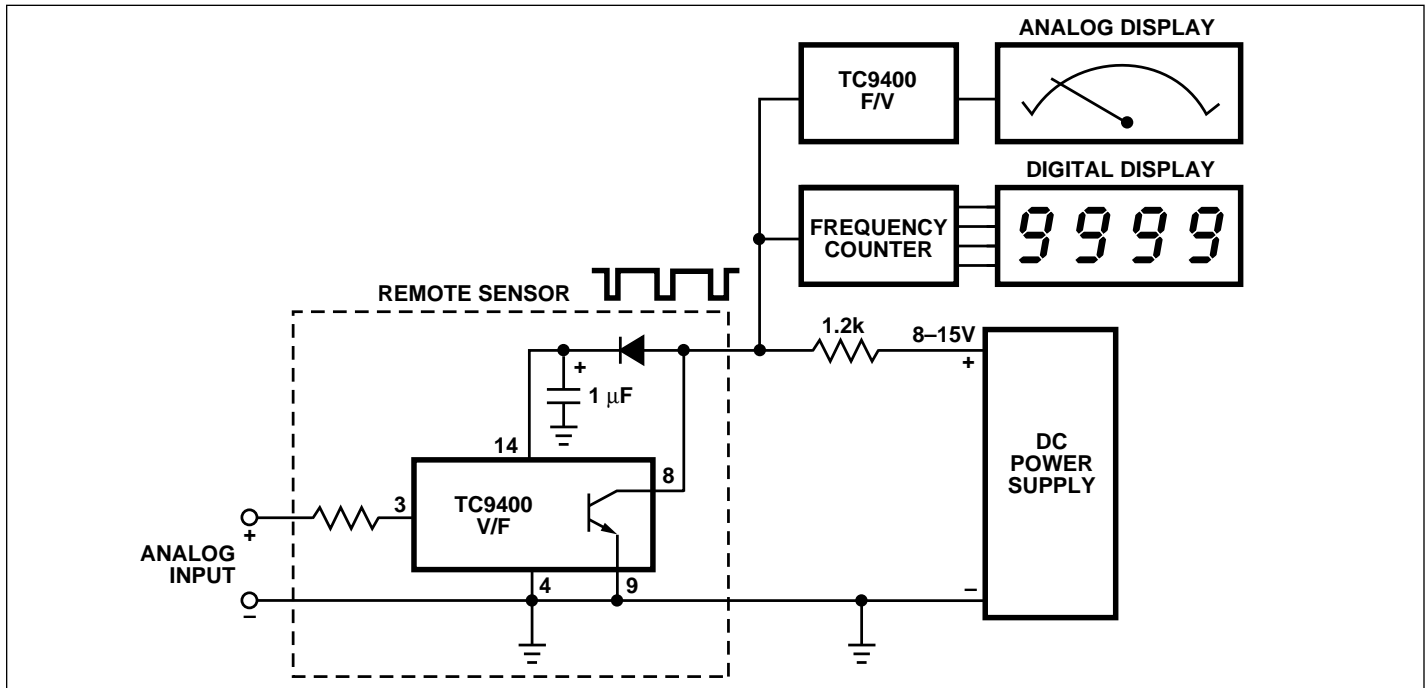

By converting an analog voltage to a linearly-proportional pulse train of short duration, it is possible to transmit this data on the same wires used to energize the V/F converter.

The TC9400 V/F converter shorts out the DC supply for 3  $\mu$ s out of each period. At 100 kHz, the supply line is down 30% of the 10  $\mu$ s period. As the frequency is lowered, the down-time decreases, so that at 1 kHz the line is down only 0.3% of the time.

Two precautions are necessary to assure that the system does not stop functioning during the shorting period. At the power supply end, a 1.2k resistor limits the current to 10 mA on a 15V supply line. This prevents the TC9400 from being operated beyond its output rating and at the same time prevents the supply from being shorted

out. At the V/F end, a capacitor is used to keep the TC9400 energized, while the diode keeps the capacitor from being discharged.

Since the TC9400 requires only 2 mA of current, a 1  $\mu$ F capacitor ensures a stable voltage (the ripple is only 6 mV). Since the 3  $\mu$ s pulses appear at the left side of the 1.2k resistor, it is easy to sense the signal here and convert the data back into a recognizable format. A frequency counter connected at this point will directly display the input voltage by counting the frequency.

If an analog output is required, a TC9400 in the F/V mode can be used to convert the frequency back into a voltage. The overall linearity is on the order of 0.03%, when both V/F and F/V are used. If only the V/F is used, 0.01% linearity can easily be achieved.

## DIGITALLY-CONTROLLED FREQUENCY SOURCE

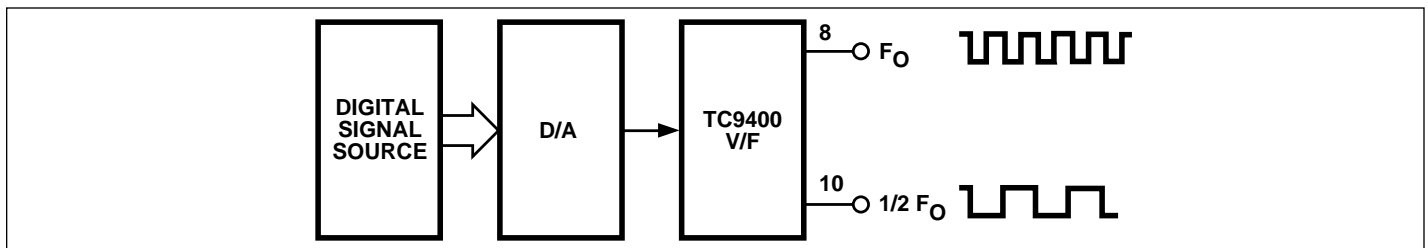

This system generates frequencies controlled by a microprocessor counter, register, or thumb-wheel switches.

Applications for such a system include computer-controlled test equipment and numerically-controlled machine tools.

# APPLICATIONS OF THE TC9400 VOLTAGE-TO-FREQUENCY/ FREQUENCY-TO-VOLTAGE CONVERTER

AN-10

## WIDE FREQUENCY RANGE PULSE GENERATOR

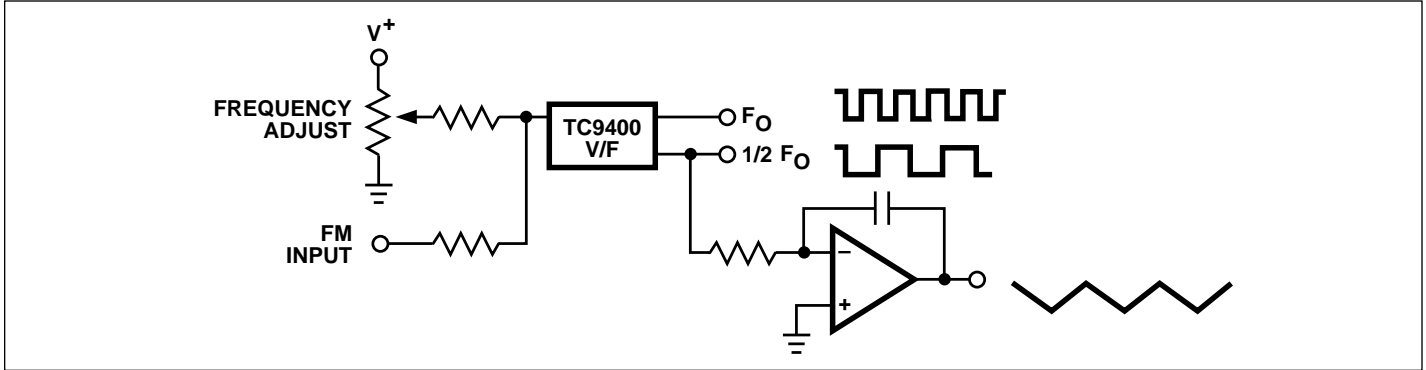

The TC9400 V/F converter is useful in the laboratory as a portable, battery-operated, low-cost frequency source. The TC9400 provides both pulse and square-wave out-

puts. By adding an op-amp integrator, a triangular waveform can also be generated. The outputs can be frequency-modulated via the FM input.

## FREQUENCY MULTIPLIER/DIVIDER WITH INFINITE RESOLUTION

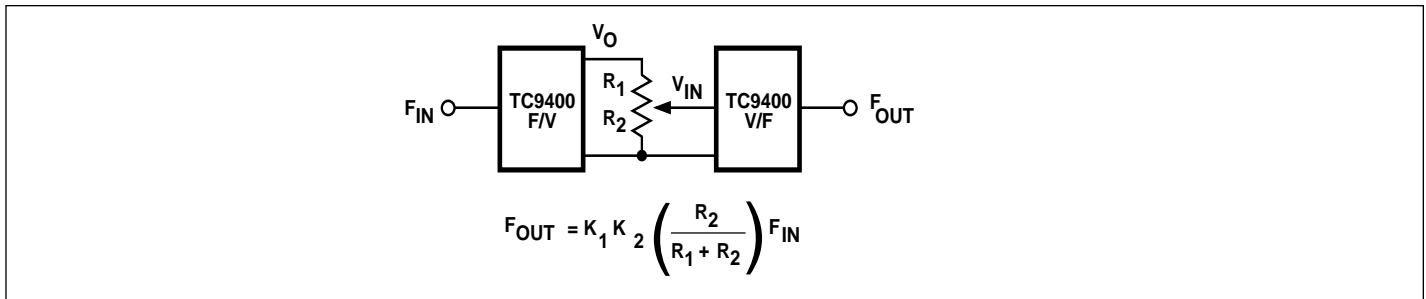

Frequency scaling can easily be performed by first converting the incoming frequency into a proportional DC voltage. This is accomplished by using the TC9400 in the F/V mode. Once the frequency is in a voltage format, it is easy to scale this voltage up or down by use of a single

potentiometer. The resultant voltage is then applied to a TC9400 V/F converter, which generates a proportional output frequency.

Since the potentiometer is infinitely variable, the division/multiplication factor can be any number, including fractions ( $K_1$  is simply  $V_O/F_{IN}$ , while  $K_2$  is  $F_O/V_{IN}$ ).

# APPLICATIONS OF THE TC9400 VOLTAGE-TO-FREQUENCY/ FREQUENCY-TO-VOLTAGE CONVERTER

AN-10

## FREQUENCY-DIFFERENCE MEASUREMENT

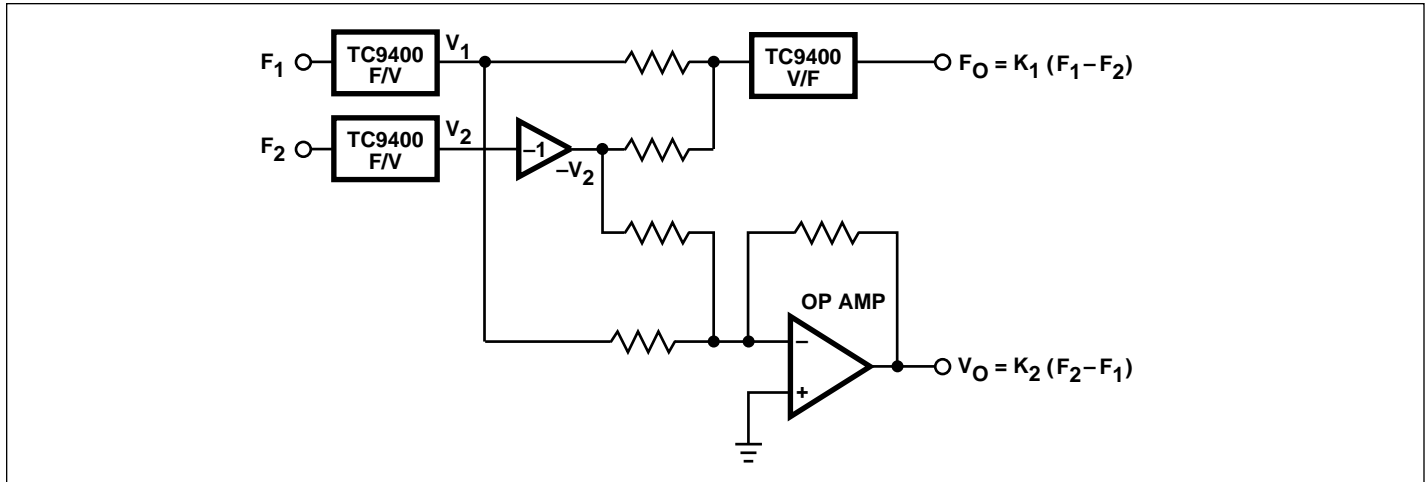

Frequency-difference measurement is accomplished by using two TC9400's in the F/V mode to convert both frequencies into two proportional analog voltages ( $V_1$  and  $V_2$ ).  $V_2$  is inverted by a unity gain inverter.  $V_1$  and  $-V_2$  are then added by the summing op-amp to give a voltage proportional to the frequency difference between  $F_2$  and  $F_1$ .

Since the TC9400 V/F input is actually the summing junction to an op-amp,  $V_1$  and  $-V_2$  can be summed at the TC9400 input to generate a frequency output proportional to the difference between  $F_1$  and  $F_2$ .

## CONVERTERS SIMPLIFY DESIGN OF FREQUENCY MULTIPLIER\*

By using a programmable digital-to-analog converter in combination with frequency-to-voltage and voltage-to-frequency converters, this circuit can multiply an input frequency by any number. Because it needs either combinational logic nor a high-speed counter, it is more flexible than competing designs, uses fewer parts, and is simpler to build.

As shown in the figure below, the V/F converter, a TelCom 9400, transforms the input frequency into a corresponding voltage. An inexpensive device, the converter requires only a few external components for setting its upper operating frequency as high as 100 kilohertz.

Next the signal is applied to the reference port of the DAC-03 d-a converter, where it is amplified by the frequency-

multiplying factor programmed into the converter by thumbwheel switches or a microprocessor. The d-a converter's output is the product of the analog input voltage and the digital gain factor.

$R_3$  sets the gain of the 741 op-amp to any value, providing trim adjustment or a convenient way to scale the d-a converter's output to a much higher or lower voltage for the final stage, a 9400 converter that operates in the voltage-to-frequency mode. The 741 and  $R_3$  can also be used to set circuit gain to non-integer values. The V/F device then converts the input voltage into a proportionally higher or lower frequency.

# APPLICATIONS OF THE TC9400 VOLTAGE-TO-FREQUENCY/ FREQUENCY-TO-VOLTAGE CONVERTER

AN-10

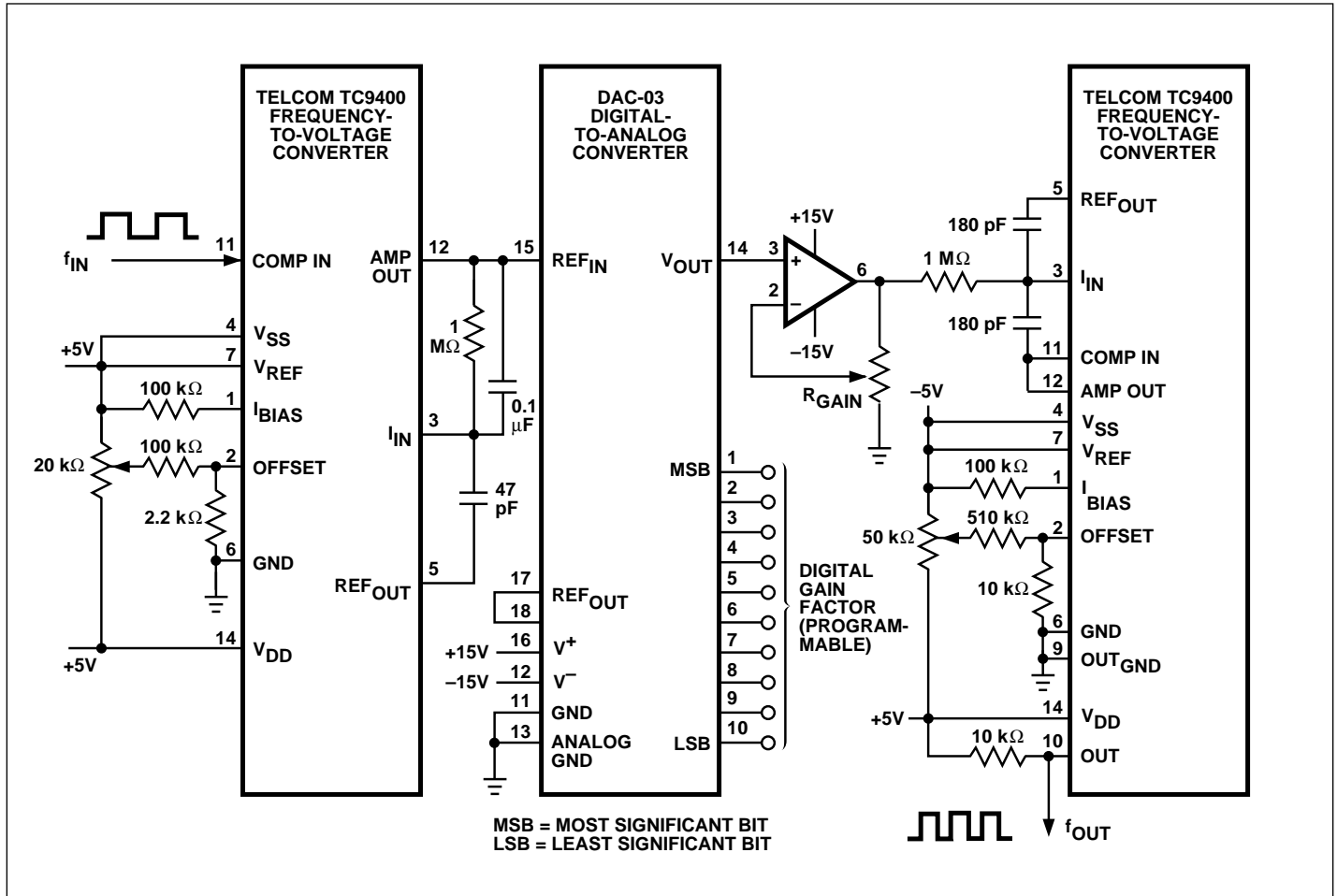

Circuit uses frequency-to-voltage-to-frequency conversion, with intermediate stage of gain between conversions, for multiplying input frequency by any number. Digital-to-analog converter is programmed digitally, by thumbwheel switches or microprocessor, for coarse selection of frequency-multiplying factor; 741 provides fine gain, enables choice of non-integer multiplication values.

\*Reprinted with permission from *Electronics*, October 12, 1978; Copyright © Mc-Graw-Hill, Inc., 1978. All rights reserved.

## Sales Offices

**TelCom Semiconductor**  
1300 Terra Bella Avenue  
P.O. Box 7267  
Mountain View, CA 94039-7267  
TEL: 415-968-9241  
FAX: 415-967-1590  
E-Mail: liter@telcom-semi.com

FAX: 512-873-8236

Hong Kong  
TEL: 852-2324-0122  
FAX: 852-2354-9957

**TelCom Semiconductor H.K. Ltd.**  
10 Sam Chuk Street, Ground  
Floor  
San Po Kong, Kowloon

**TelCom Semiconductor**  
Austin Product Center  
9101 Burnet Rd. Suite 214  
Austin, TX 78758  
TEL: 512-873-7100