

# Assembly Manual for the N3ZI LCD Digital Display Semi Kit

Your kit includes

- a) Assembled LCD Module
- b) Programmed Microcontroller (ATTiny24)
- c) Crystal

You will also need, as a minimum.

- d) 3 each 22pf capacitors
- e) 2 each 100K resistors
- f) One 0.1uF Capacitor.
- g) Circuit Board of some type
- h) Regulated power source, 3.3 to 5V.
- i) 2 pushbutton switches ( SPST, N.O.), temp for programming.
- j) 10K potentiometer (optional) to control the LCD contrast.

Assemble everything per the schematic. Be careful with the power and ground connection to the Microprocessor. It's a 14 Pin DIP, but the power and ground pins are different from most 14 Pin digital IC's. Carefully wire per the schematic. The drawing for the LCD module is attached showing the pin numbering.

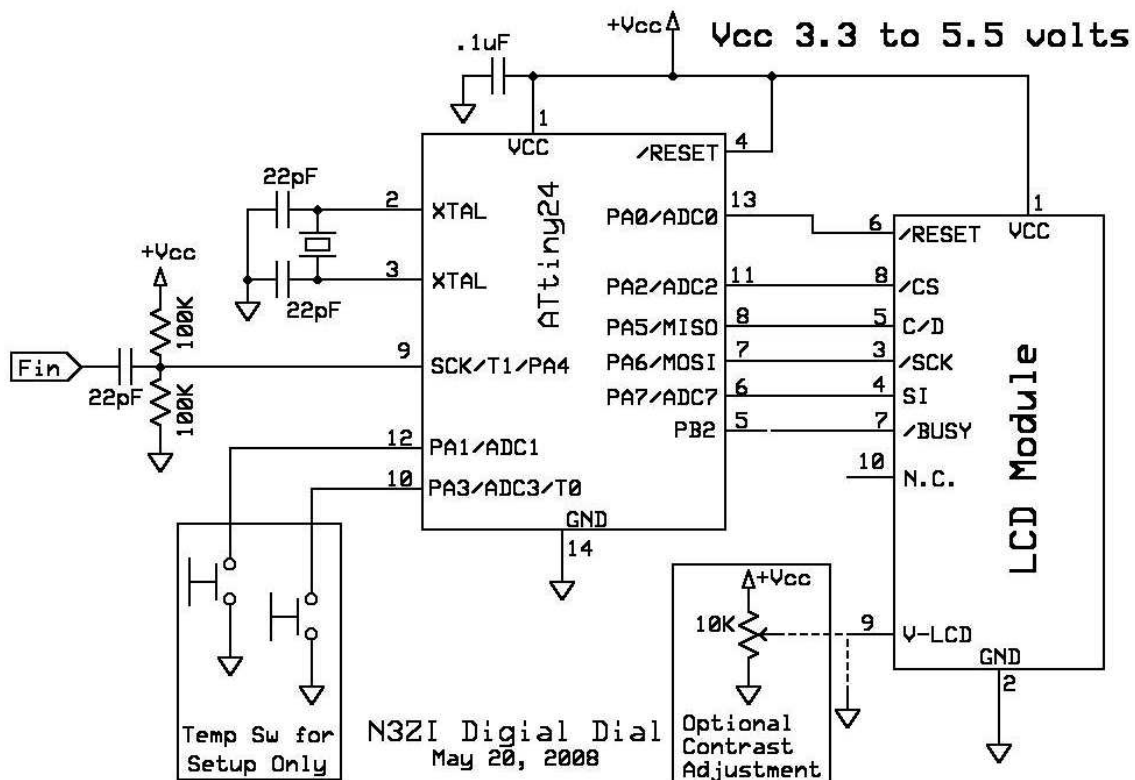

The LCD contrast depends a bit on personal preference. If it's set very wrong, you may see a blank display, or all 8's. I have found that a voltage about 3-4v below the Vcc works well. The easiest thing to do is to run the counter with Vcc = 3.6 volts, and simply ground the V-LCD pin(#9). If you are using a 5v supply you will need the potentiometer, and set it for about 2 volts.

You should also use a regulated power source. I have used it with an adjustable 3 terminal regular (LM317) and it seems to work fine over a range of voltages from 2.7 to 5.5v. But I'm not recommending anything under 3.3v because that would be contrary to the manufacturer's recommendations for the microprocessor. It draws about 10mA during setup up and initialization, but during normal operation it drops to about 3mA. (I put the uP into sleep mode between readings, and the LCD is only actually updated when the value changes.) I've also run mine from a 3.6volt lithium battery, which seems to work fine. If you are using a prescaler I.C, you should probably run everything at 5 volts. Most divider chips will clock faster at 5 volts.

### **Initial Set Up:**

When you first power up the counter, a date code should appear for about 2 seconds, then the frequency reading will show. If there is no input, then the IF frequency will be displayed.

If that all looks ok, turn it off, hold one of the push buttons down, and apply power. The date code will appear and stay there until you release the pushbutton.

The first step is setting the timebase factor. The default is 1. Just do nothing to keep the default, and it will move to the next step in 5 seconds. The way the setup works, is the buttons increase and decrease the number displayed. Once you've gotten to the value you want. Simply release all the buttons and after about 5 seconds it will proceed to the next step. Normally you just keep the default (1) But if you've put a divide by "N" chip in the counter input, then you can change the timebase factor value to match. This factor simply slows the timebase down by that factor. If set to 4 it causes the counter to count the input 4 times over, thus canceling out the effect of your input divider. Of course this also slows the update rate by the same factor. Decrementing beyond 0 will make it negative, be careful not to accidentally enter a negative value for the timebase factor.

The next step is for setting the decimal point position. 12.345.6 will be displayed. Pressing either button sequences the decimal points through the possible positions. The default is with the decimal point between the 1<sup>st</sup> and second digits. You can also turn them off. The position is strictly cosmetic, but the readout can be quite confusing if they are set wrong. Stick with the default, except for some special cases, see table below.

The next parameter is the IF frequency. The way the setup works, is the buttons increase and decrease the number displayed. Once you've gotten to the value you want. Simply release all the buttons and after about 3 seconds it will proceed to the next step. Holding a button down continuously will change the value at an accelerating rate. If the value is negative, a minus sign will appear at the far left on the display. If your radio uses a subtractive frequency plan, you need to enter the IF as a negative number. The minus sign is shown on the far left side of the display. Your unit will likely be shipped with an IF of +11.000.0 If your radio has a subtractive freq scheme (i.e. a 7MHz radio with 4Mhz VFO and a 11Mhz IF.) Then you have to change the IF to -11.000.0 To do this you just keep reducing the IF value by holding the button down, eventually it will go to zero and the minus sign comes on, and you keep going. It takes about 90 seconds to go from +11 to -11 MHz. Once you are close, release the button, and use the buttons to tweak it in. The change speed slows the instant the button is released. After your satisfied, just release both buttons, and after 5 seconds of no buttons being pressed, the values will be saved in EEPROM. Next time you power up these values will be used.

If you want to use it as a frequency counter, just set the IF to 0. If you are not sure of your IF frequency, set it to zero, then use the device as a frequency counter to measure your radio's BFO frequency. Then go through the setup again using that value for the IF.

## Calibration:

Once you get it hooked up to your radio, you may want a fine tweak of the IF, to compensate for a variety of errors, including the frequency error in the crystal. Generally these are less than 1 KHz. Just tune your radio to a known frequency, observe the readout, and compute the error by subtracting the readout value from the expected frequency. Then go through the set-up again, and change your IF setting by exactly that amount. Calibrating this way eliminates the need for a trimmer capacitor in the xtal oscillator circuit. If you want you could use a 50pf trimmer in place of one of the 22pf capacitors, and using that to tweak the crystal oscillator to exactly 13.435MHz. But this isn't necessary. There is also a mathematical parameter inside the software related to the oscillator frequency. In my first version of the software there was a setup step which allowed the user to change this. But I found that this was just too confusing, so I removed it. It's easier to simply tweak the IF setting to calibrate.

You can remove the switches once everything is set, they aren't used for anything during normal operation.

Anti jitter logic. The s/w designed so that the last digit will not jitter between two values. Even if you purposely set your VFO on the edge of two readings, it won't jitter. Now if your VFO is very unstable, then you may see some jitter. In essence you have 1 LSD (100hz) of hysteresis in the counter.

With these default settings, the counter works as a very smooth digital dial for a VFO. If you want higher precision, you can change the timebase factor to 10, and the DP setting to 3. This gives you a 10Hz readout, but at a rather slow update rate. If your VFO is higher than 5.5MHz, you will need to add a counter divider chip, such as a 74HC161, 74HC163, 74HC390, 74HC393. In general you should use the smallest prescale divider possible. The table below shows some of the configuration options possible.

Mode	External Prescaler	Resolution	Update Rate (Hz)	Max VFO Freq	Timebase Factor	Decimal Point
Normal	None	100Hz	50Hz	5.5MHz	1	2
Fine	None	10Hz	5Hz	5.5MHz	10	3
10-Fast	Div / 10	1KHz	50Hz	55MHz	1	1
10-Slow	Div / 10	100Hz	5Hz	55MHz	10	2
5	Div / 5	100Hz	10Hz	27MHz	5	2
4	Div / 4	100Hz	12Hz	21MHz	4	2
2	Div / 2	100Hz	25Hz	11MHz	2	2
16	Div / 16	100Hz	3Hz	88MHz	16	2

## Other Considerations

The readout may show a negative sign, which can be ignored under normal operation. But basically if your radio has a frequency plan that causes the VFO frequency to move in the opposite direction of the operating frequency a minus sign will be shown.

The LCD module has mounting holes in the corners. They are rather small, but I have found that #14 wire fits through nicely, and they are plated so you can solder the wire in place. Alternatively, you could drill them out (at your own risk) or get some very small mounting hardware.

The S/W was written in 'C' using an optimizing compiler. The program memory is full, at last count there were just a few unused bytes. The lock bit in the device is set, so you cannot copy the code. You can however, erase the chip, but you will then lose the code, and I'm not planning on releasing the S/W. However, if you are experienced at programming these micro's and have some ideas, please email me and we can work something out.  
n3zi@pongrance.com

May 22, 2008

Copyright 2008, Douglas Pongrance

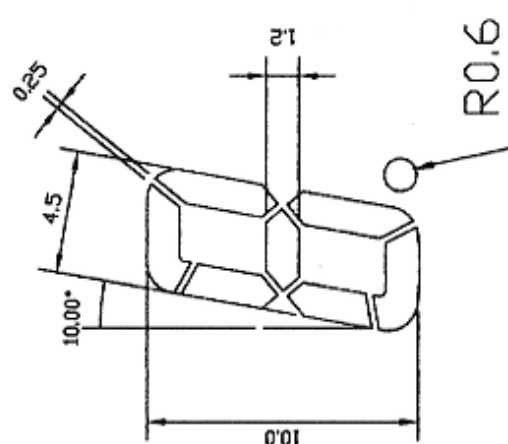
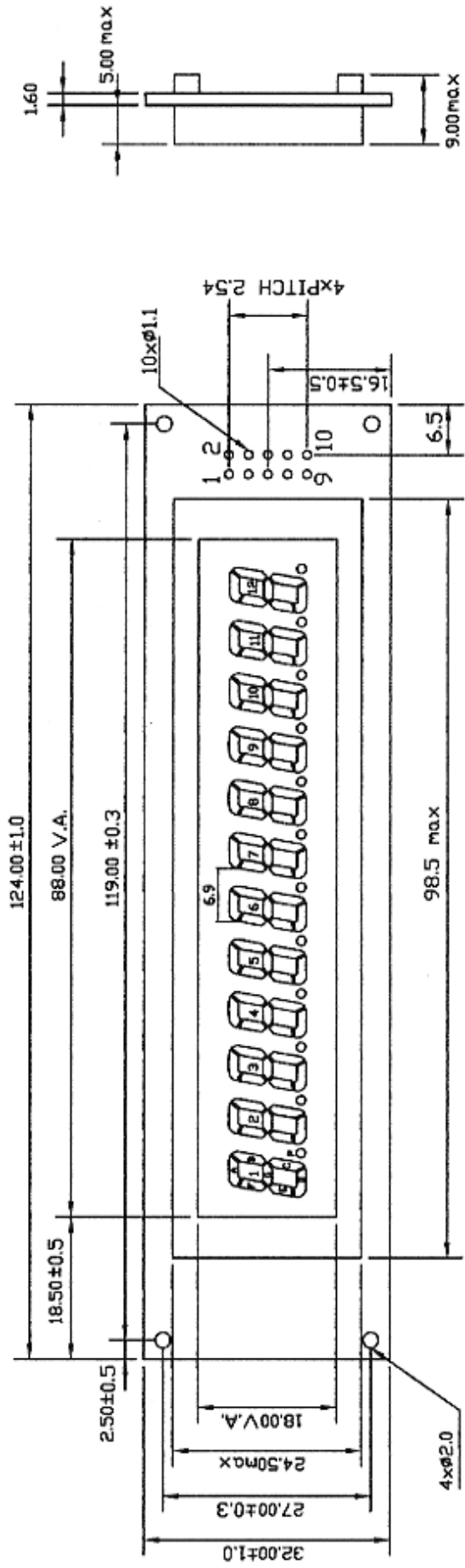

Dfn No	Designation
1	VCC
2	VSS
3	SCK
4	SI
5	C/D
6	RESET
7	BUSY
8	CS
9	V <sub>Lc</sub>
10	N.C

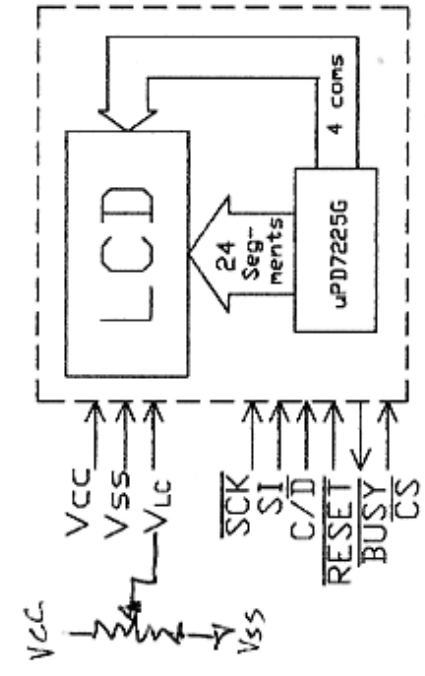

module house			
POLARIZER	VIEWING DIR.	SCALE	DRG. NO.
Reflective	LCD NO.	Not in scale	DATE
VOLTAGE	OPERAT. TEMP.	APP. BY	REV.
	-20 to 70°C	-	1
			SH
			KTM-S1201
			OF