



# Freescle Technology Forum

Collaboration. Innovation. Inspiration.

July 16, 2009

## Solutions for Electrical Traction Motor Drive

Regenerative Breaking (AA119)

**Leos Chalupa, Ph.D.**

Senior System Solution Engineer

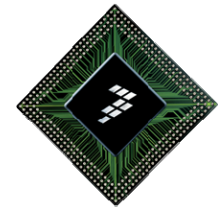

Freescle™ and the Freescle logo are trademarks of Freescle Semiconductor, Inc. All other product or service names are the property of their respective owners. © Freescle Semiconductor, Inc. 2009.



## Session Content

- ▶ Kinetic Energy Recovery System
- ▶ Motor / Generator
- ▶ KERS Control Unit
- ▶ Energy Storage System
- ▶ Freescale Advanced Peripherals
- ▶ Motor Control on Freescale Website

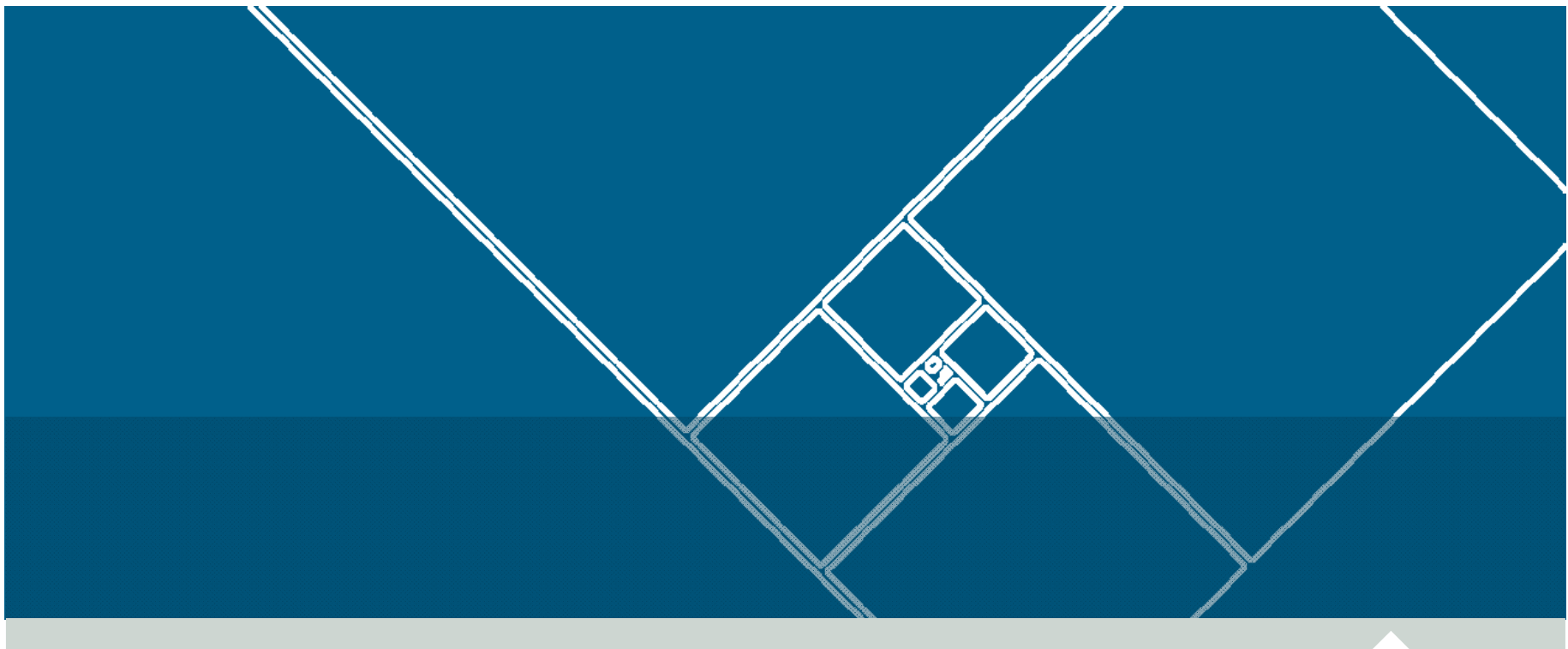

# Kinetic Energy Recovery System

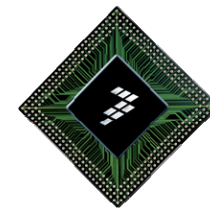

# Typical Hybrid System

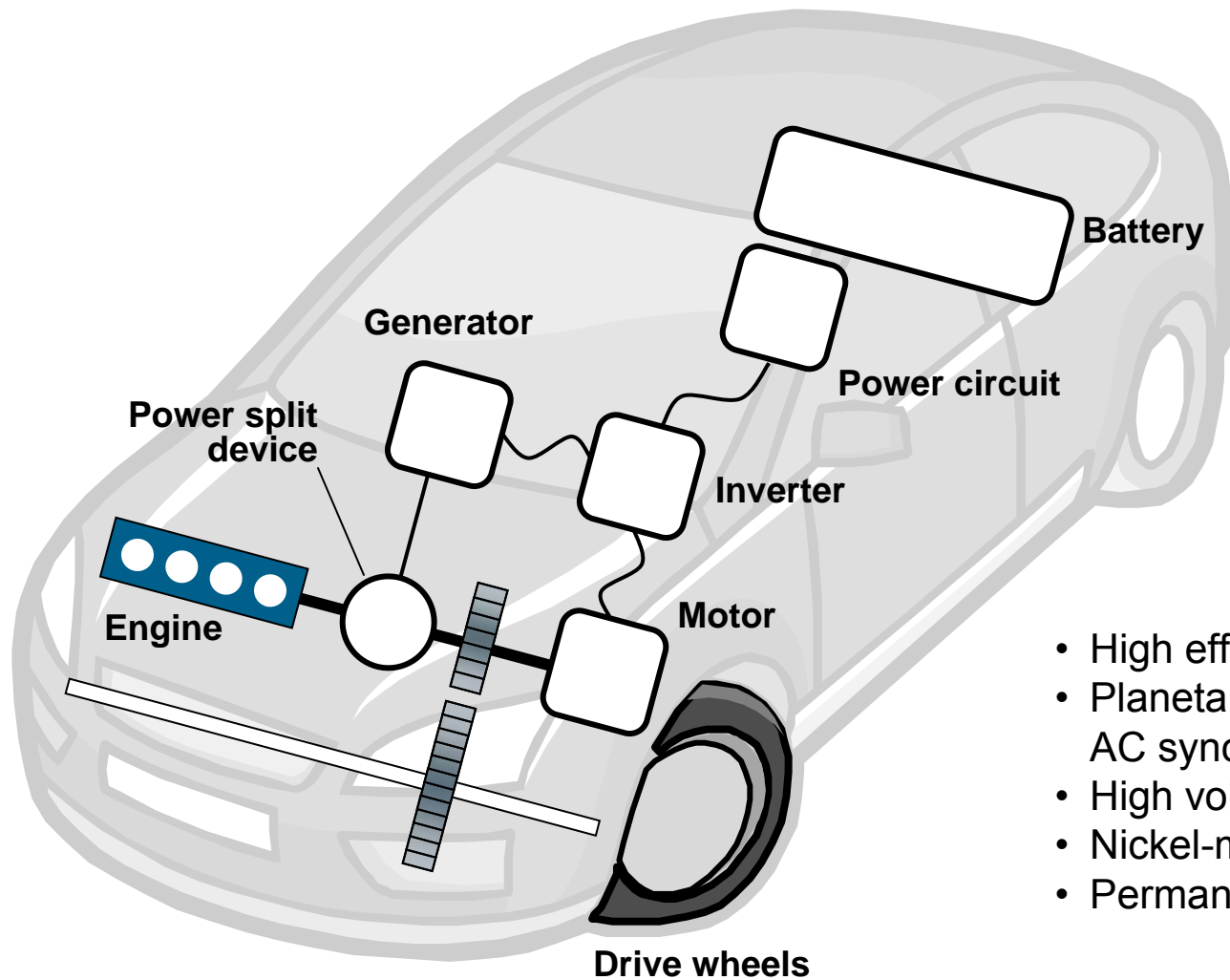

- High efficiency gas engine
- Planetary gear power split device
- AC synchronous generator
- High voltage AC-DC inverter
- Nickel-metal hydride battery
- Permanent magnet AC motor

# Hybrid Powertrain Roadmap

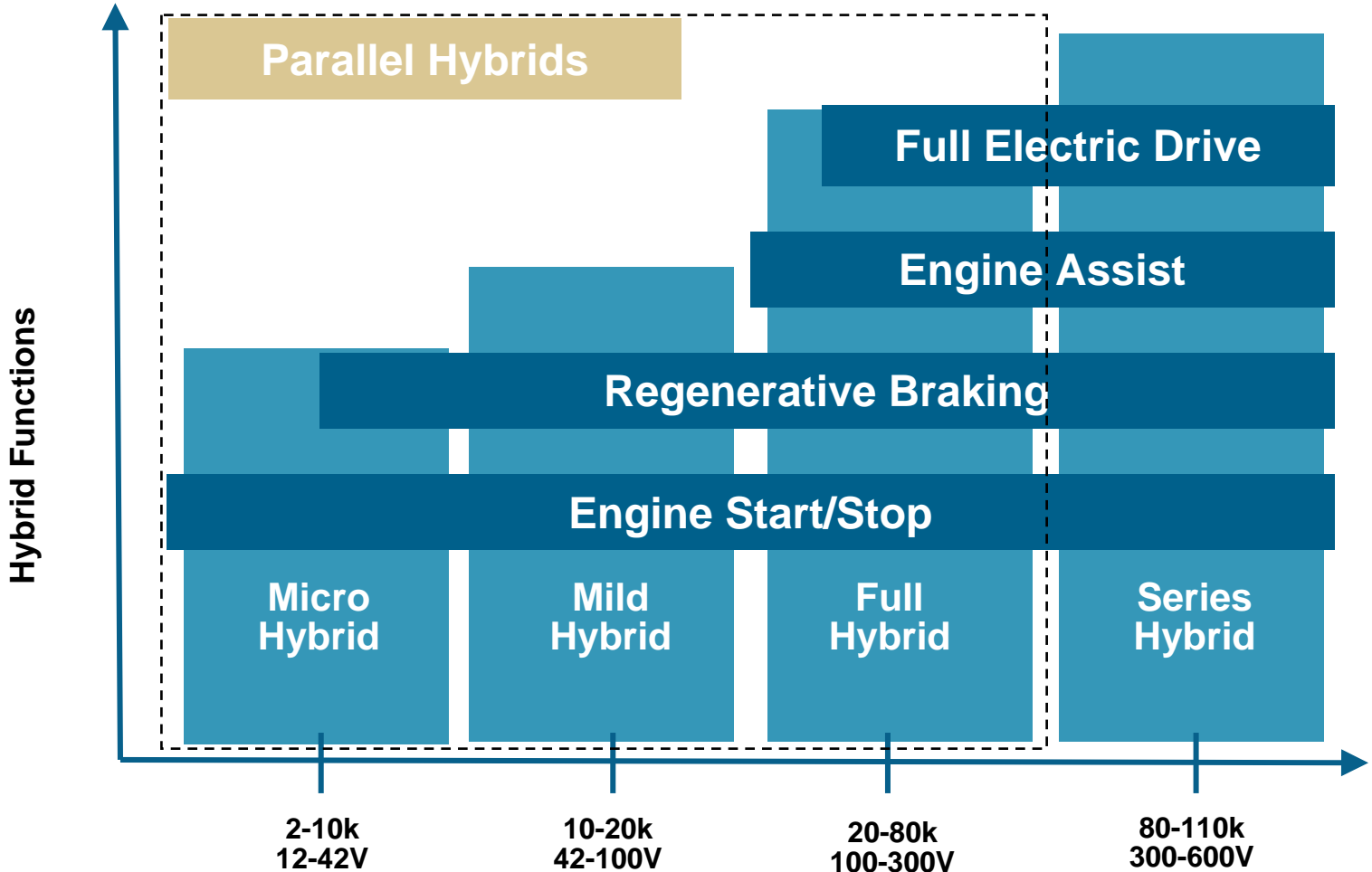

# Driving Hybrid

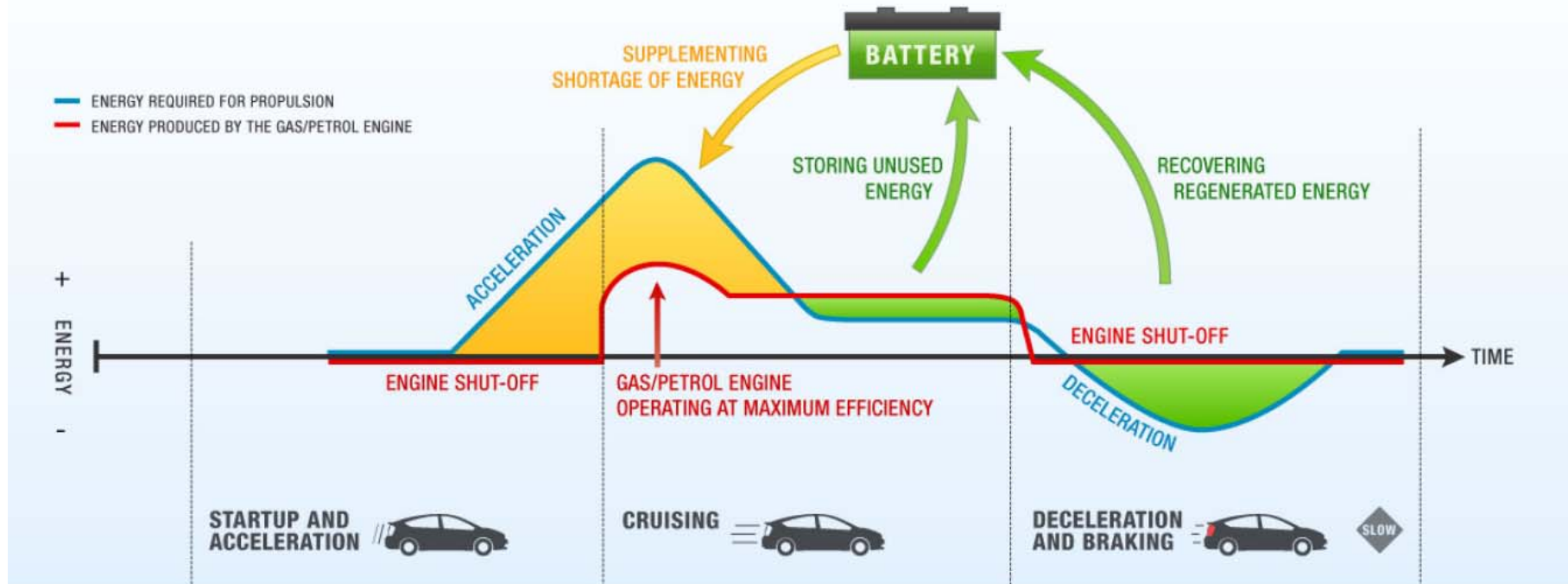

Source: TOYOTA, Hybrid Synergy Drive, Information Portal

## Hybrid strength

- ▶ **Regenerative Braking.** The electric motor applies resistance to the drivetrain causing the wheels to slow down. In return, the energy from the wheels turns the motor, which functions as a generator, converting energy normally wasted during coasting and braking into electricity, which is stored in a battery until needed by the electric motor.
- ▶ **Electric Motor Drive/Assist.** The electric motor provides additional power to assist the engine in accelerating, passing, or hill climbing. This allows a smaller, more efficient engine to be used. In some vehicles, the motor alone provides power for low-speed driving conditions where internal combustion engines are least efficient.

# Kinetic Energy Recovery Systems

- ▶ Kinetic Energy Recovery Systems (KERS) are currently in use for the motor sport Formula One's 2009 season, and under development for road vehicles.

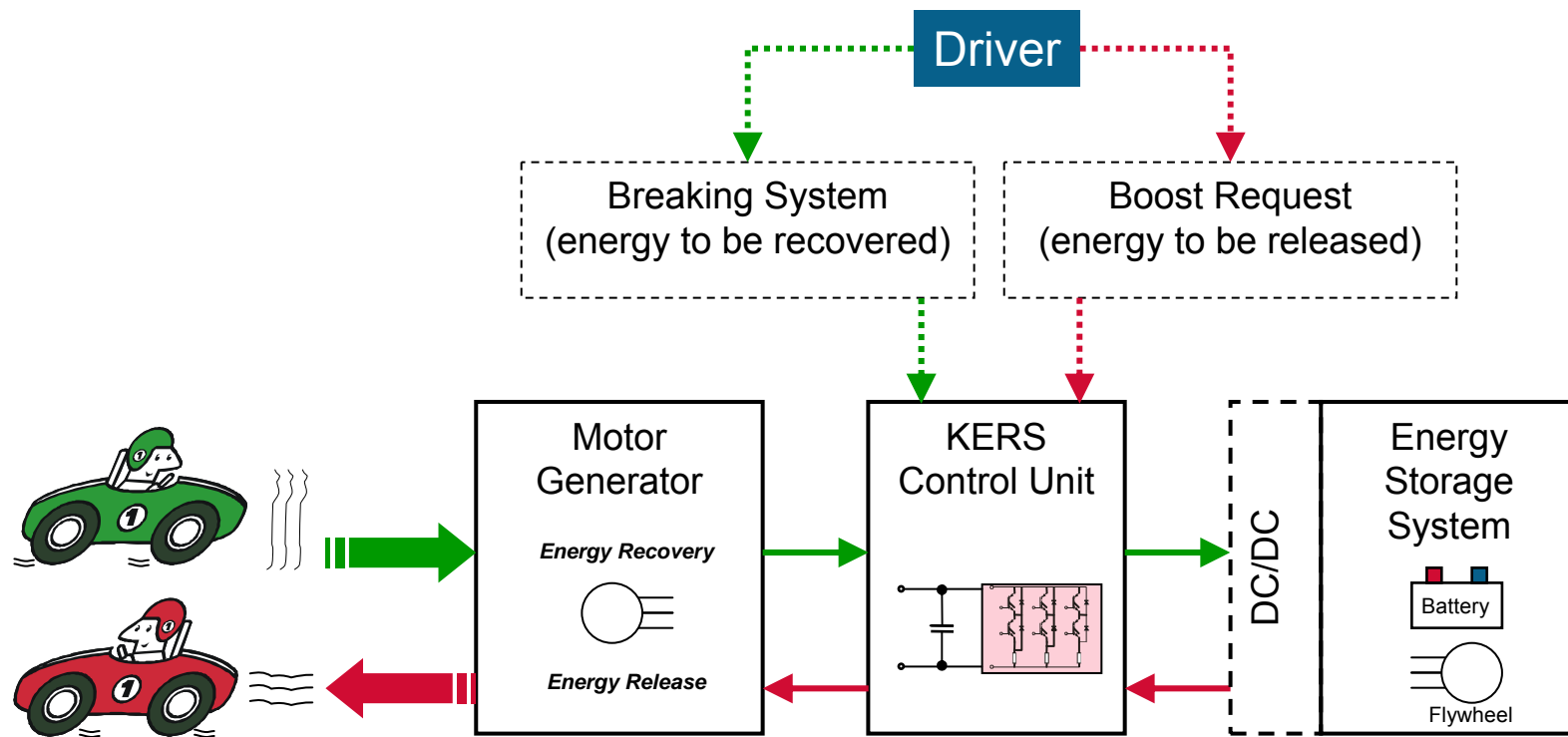

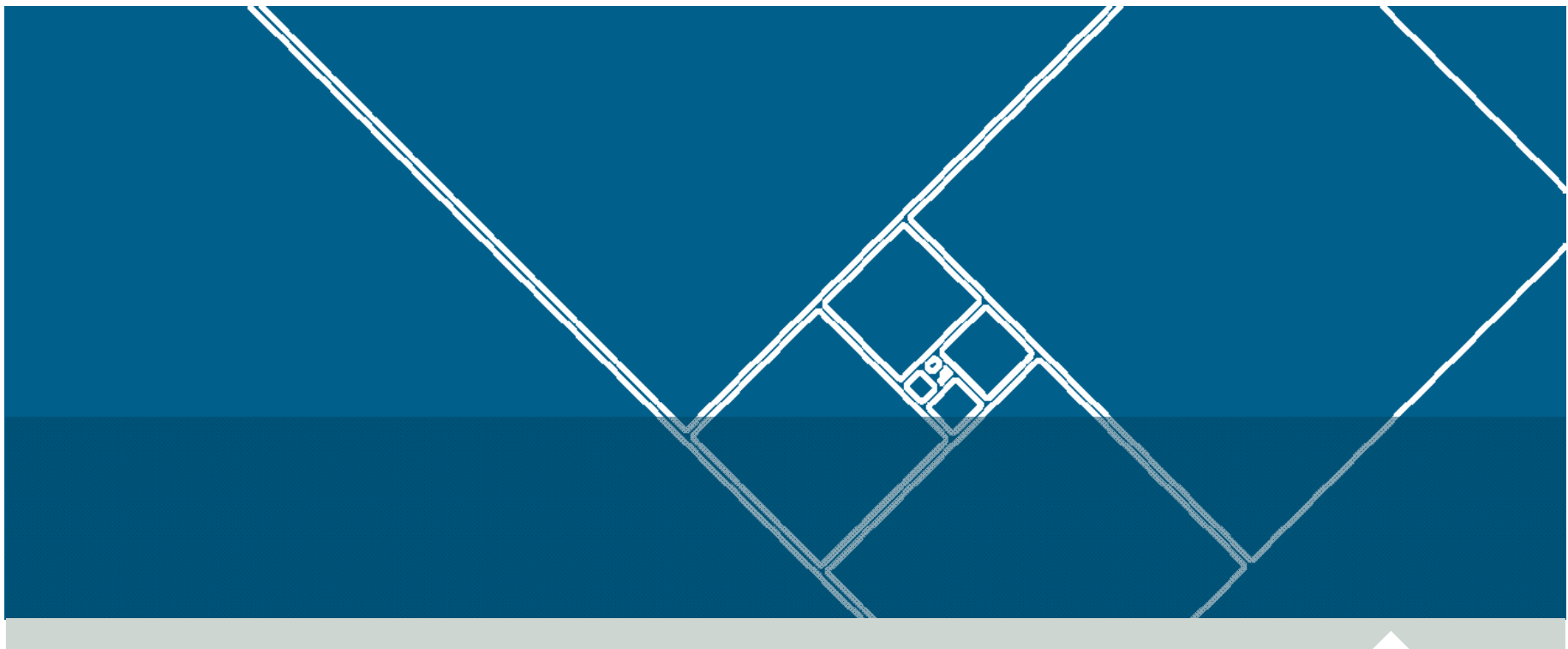

# Motor / Generator

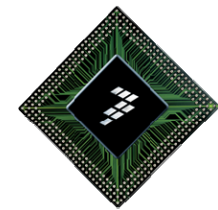

# Electric Motor Type Classification

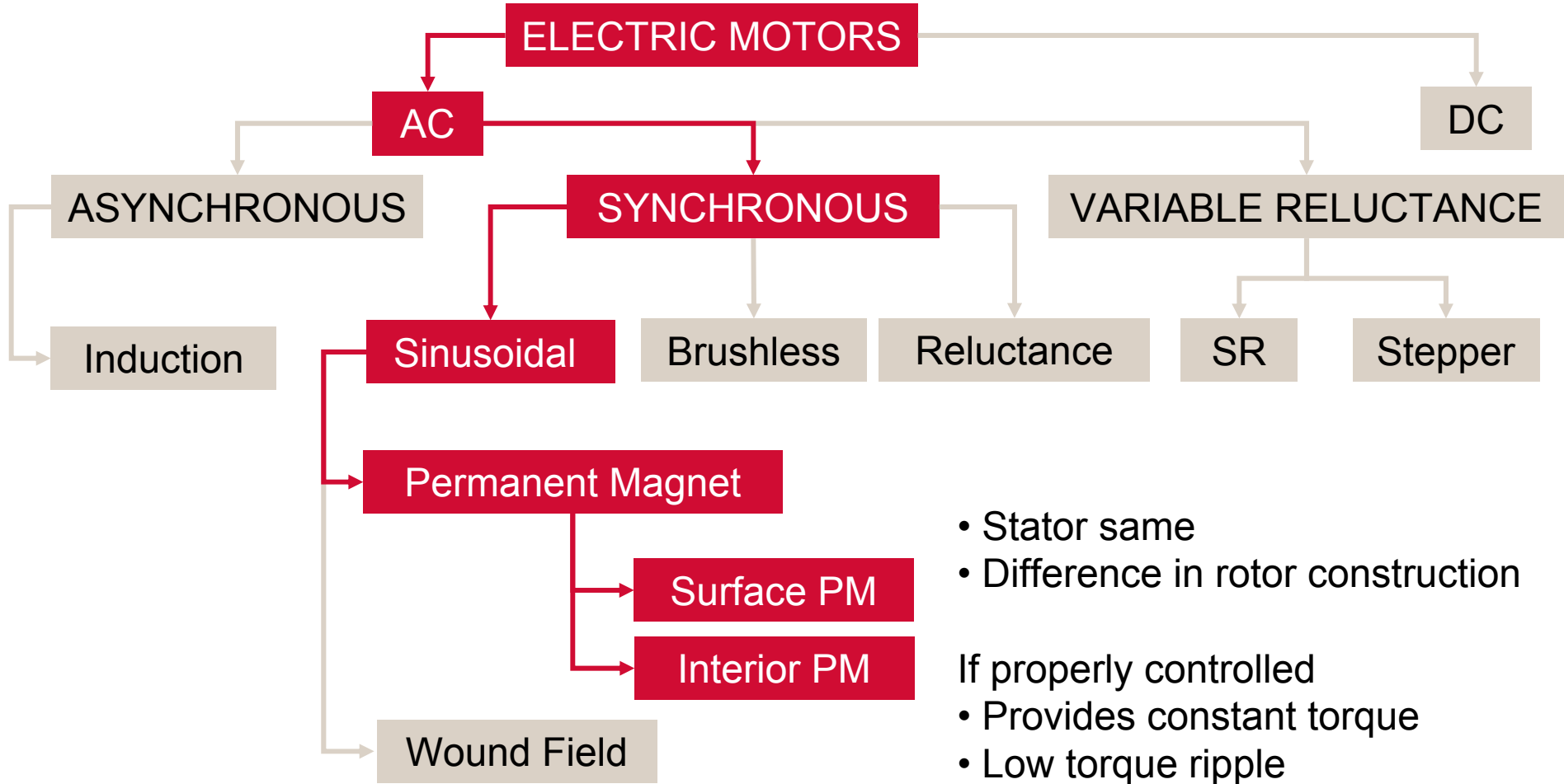

# Asynchronous vs. Synchronous

- ▶ 3-phase winding on the stator
  - distributed or concentrated
- ▶ Assumed sinusoidal flux distribution in air gap
- ▶ Different rotor construction & consequences
  - ACIM
    - Squirrel cage (rugged, reliable, economical)
    - No brushes, no PM
    - Low maintenance cost
  - Synchronous
    - Rotor with permanent magnet
    - High efficiency (no rotor losses)
- ▶ Synchronous motor rotates at the same frequency as the revolving magnetic field
- ▶ Asynchronous means that the mechanical speed of the rotor is generally different from the speed of the revolving magnetic field

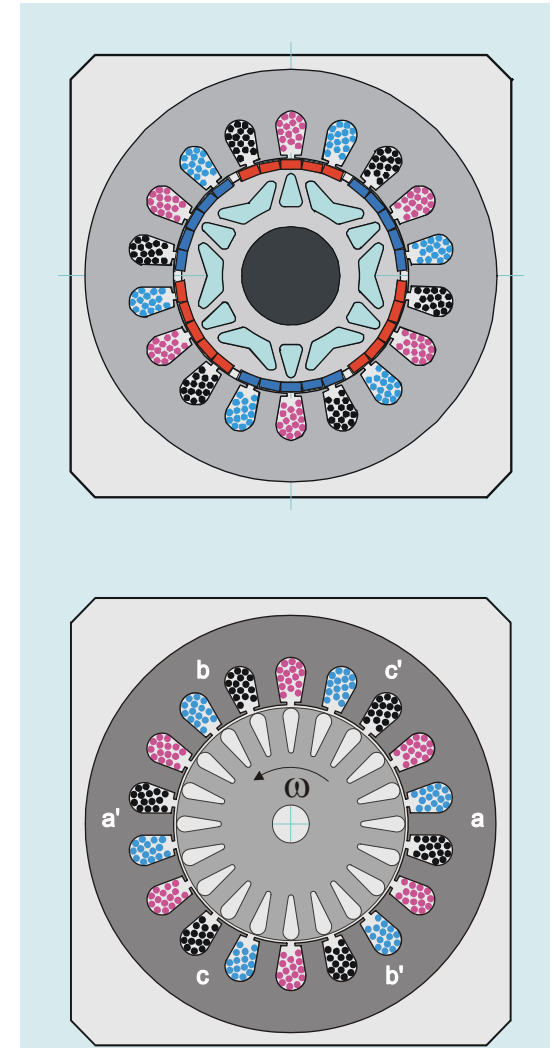

# Trapezoidal vs. Sinusoidal PM Machine

- ▶ Sinusoidal” or “Sinewave” machine means Synchronous (PMSM)
- ▶ Trapezoidal means brushless DC (BLDC) motors
- ▶ Differences in flux distribution
- ▶ Six-Step control vs. Field-Oriented Control
- ▶ Both requires position information
- ▶ BLDC motor control
  - 2 of the 3 stator phases are excited at any time
  - 1 unexcited phase used as sensor (BLDC Sensorless)
- ▶ Synchronous motor
  - All 3 phases persistently excited at any time
  - Sensorless algorithm becomes complicated

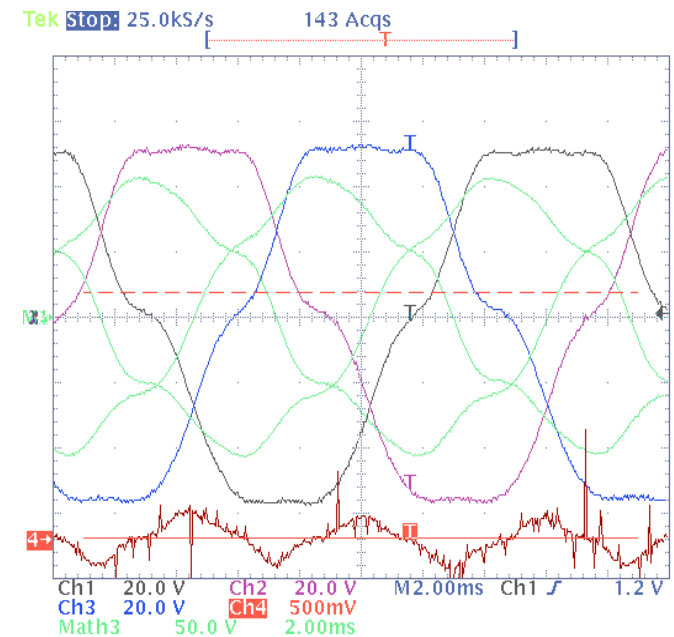

# Motor Reversal

Magnetic Flux Linkages of phase A,B,C

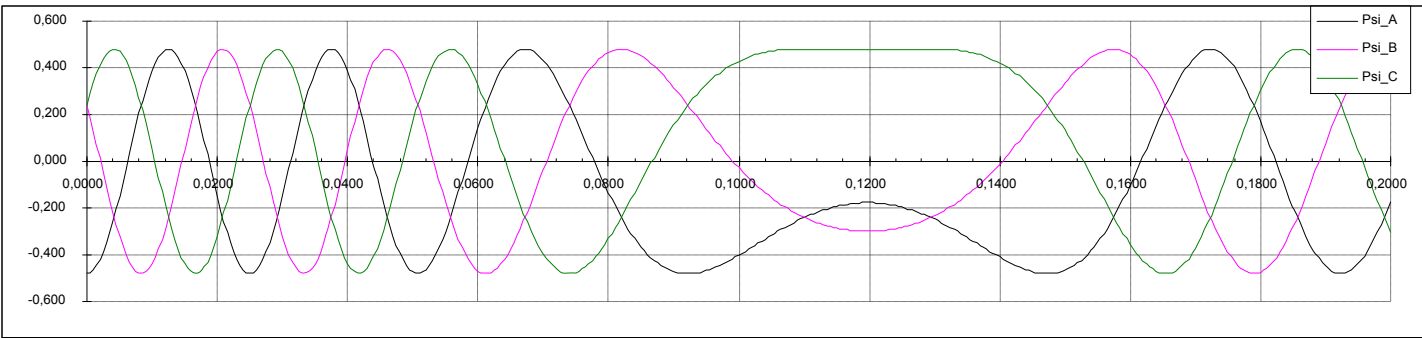

Back-EMF voltages of phase A,B,C

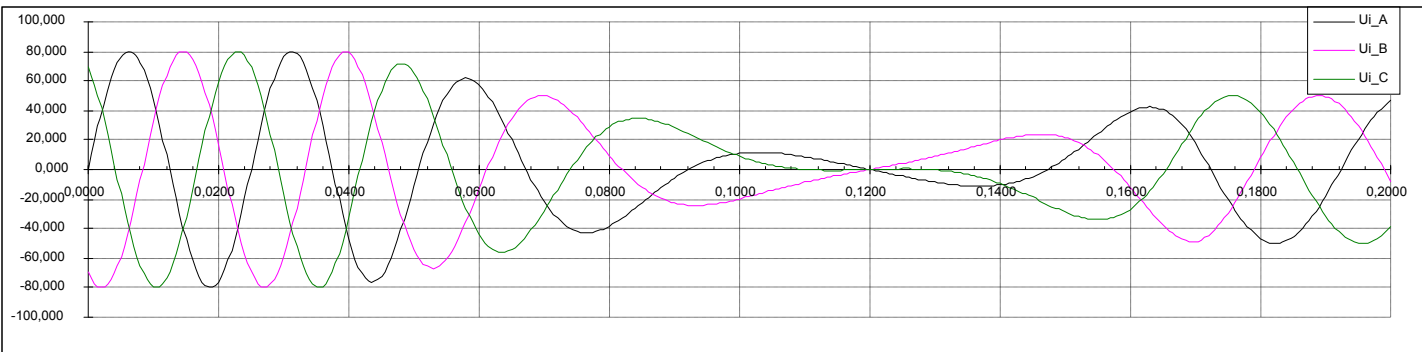

Back-EMF phase-to-phase voltages A,B,C

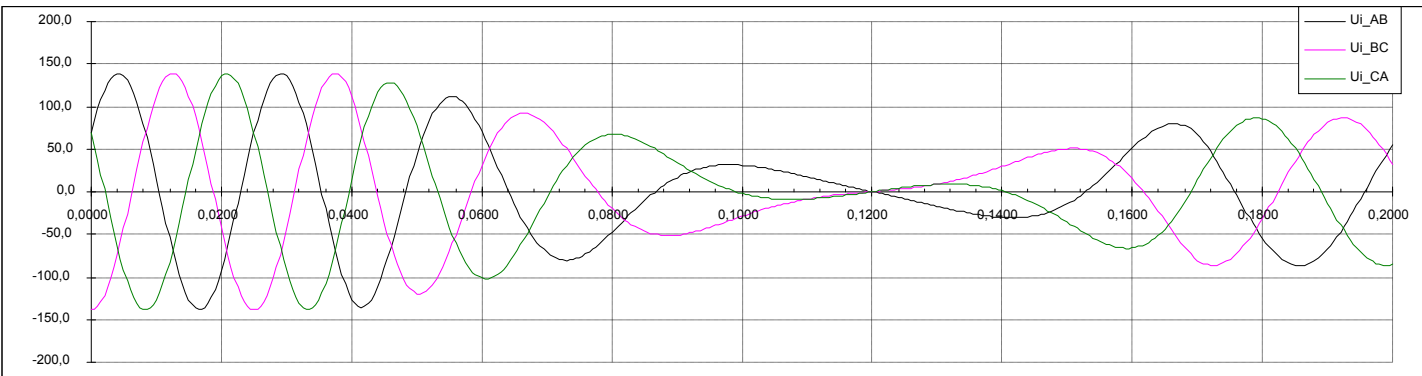

speed

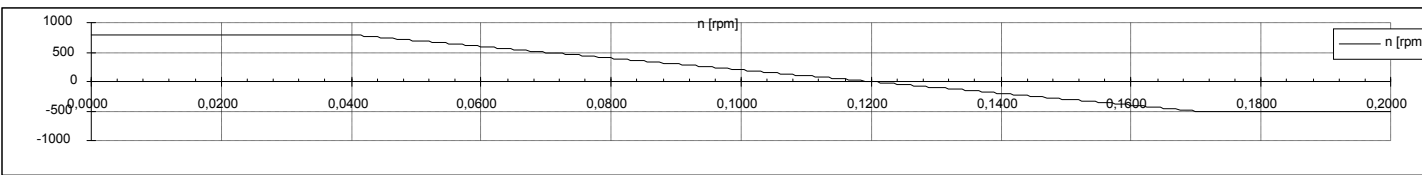

# Radial PMSM Torque Basics

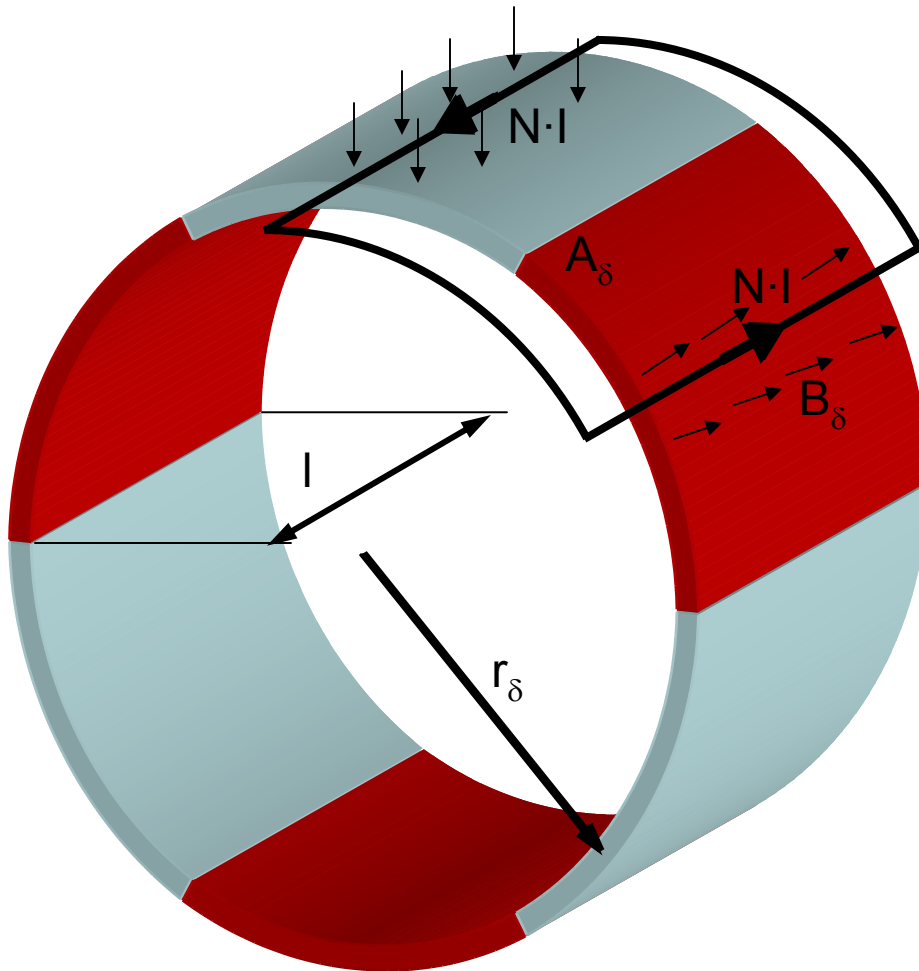

Torque

$$F = B_\delta \cdot N \cdot I \cdot l$$

$$T \approx 2p_p \cdot F \cdot r_\delta = 2p_p \cdot B_\delta \cdot N \cdot I \cdot l \cdot r_\delta$$

$$T \approx \frac{p_p}{\pi} \cdot B_\delta \cdot A_{\delta_\Sigma} \cdot N \cdot I \approx \Psi \cdot I$$

$$T \approx \frac{p_p}{\pi} \cdot B_\delta \cdot A_{\delta_\Sigma} \cdot A_{Cu} \cdot \sigma_{Cu}$$

Power

$$P = T \cdot \omega_m$$

$$P \approx \frac{p_p}{\pi} \cdot \omega_m \cdot B_\delta \cdot A_{\delta_\Sigma} \cdot A_{Cu} \cdot \sigma_{Cu}$$

$$P \approx \frac{1}{\pi} \cdot \omega_e \cdot B_\delta \cdot A_{\delta_\Sigma} \cdot A_{Cu} \cdot \sigma_{Cu} \approx U_i \cdot I$$

where

$$A_{\delta_\Sigma} = 2\pi \cdot l \cdot r_\delta$$

$$N \cdot I = A_{Cu} \cdot \sigma_{Cu}$$

# Radial PMSM Torque Basics

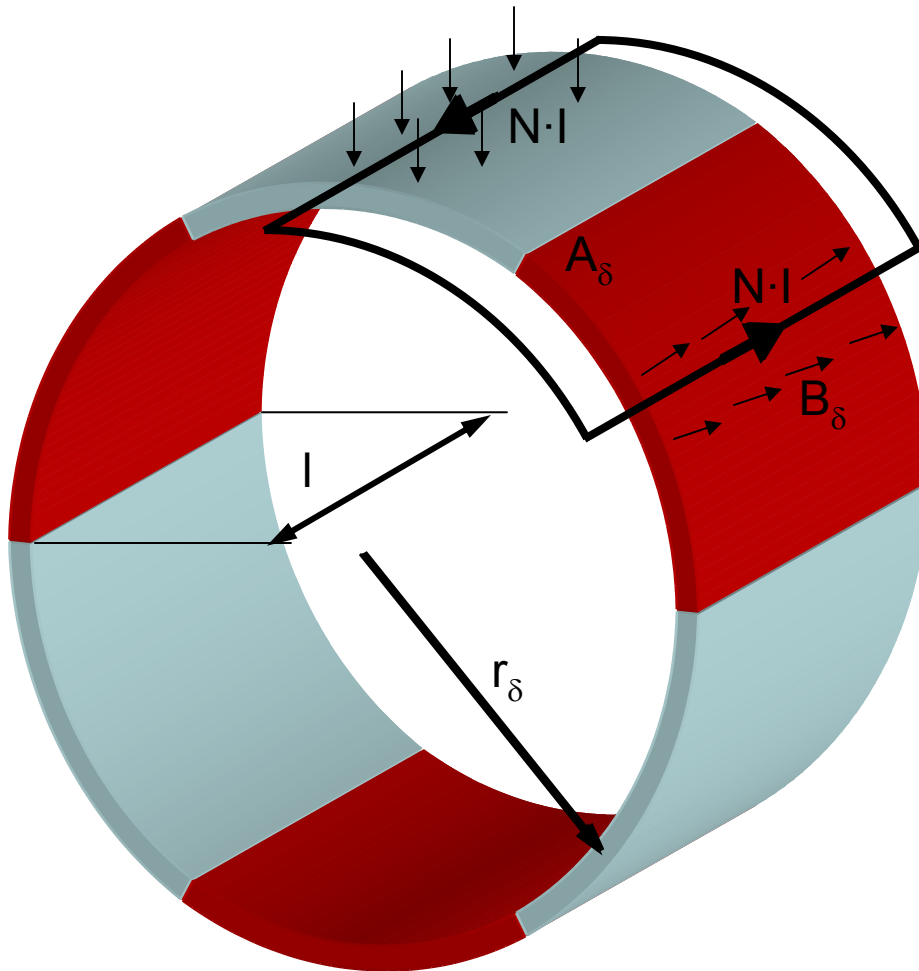

Torque

$$F = B_\delta \cdot N \cdot I \cdot l$$

$$T \approx 2p_p \cdot F \cdot r_\delta = 2p_p \cdot B_\delta \cdot N \cdot I \cdot l \cdot r_\delta$$

$$T \approx \frac{p_p}{\pi} \cdot B_\delta \cdot A_{\delta_\Sigma} \cdot N \cdot I \approx \Psi \cdot I$$

$$T \approx \frac{p_p}{\pi} \cdot B_\delta \cdot A_{\delta_\Sigma} \cdot A_{Cu} \cdot \sigma_{Cu}$$

Power

$$P = T \cdot \omega_m$$

$$P \approx \frac{p_p}{\pi} \cdot \omega_m \cdot B_\delta \cdot A_{\delta_\Sigma} \cdot A_{Cu} \cdot \sigma_{Cu}$$

$$P \approx \frac{1}{\pi} \cdot \omega_e \cdot B_\delta \cdot A_{\delta_\Sigma} \cdot A_{Cu} \cdot \sigma_{Cu} \approx U_i \cdot I$$

where

$$A_{\delta_\Sigma} = 2\pi \cdot l \cdot r_\delta$$

$$N \cdot I = A_{Cu} \cdot \sigma_{Cu}$$

# Radial PMSM Torque Basics

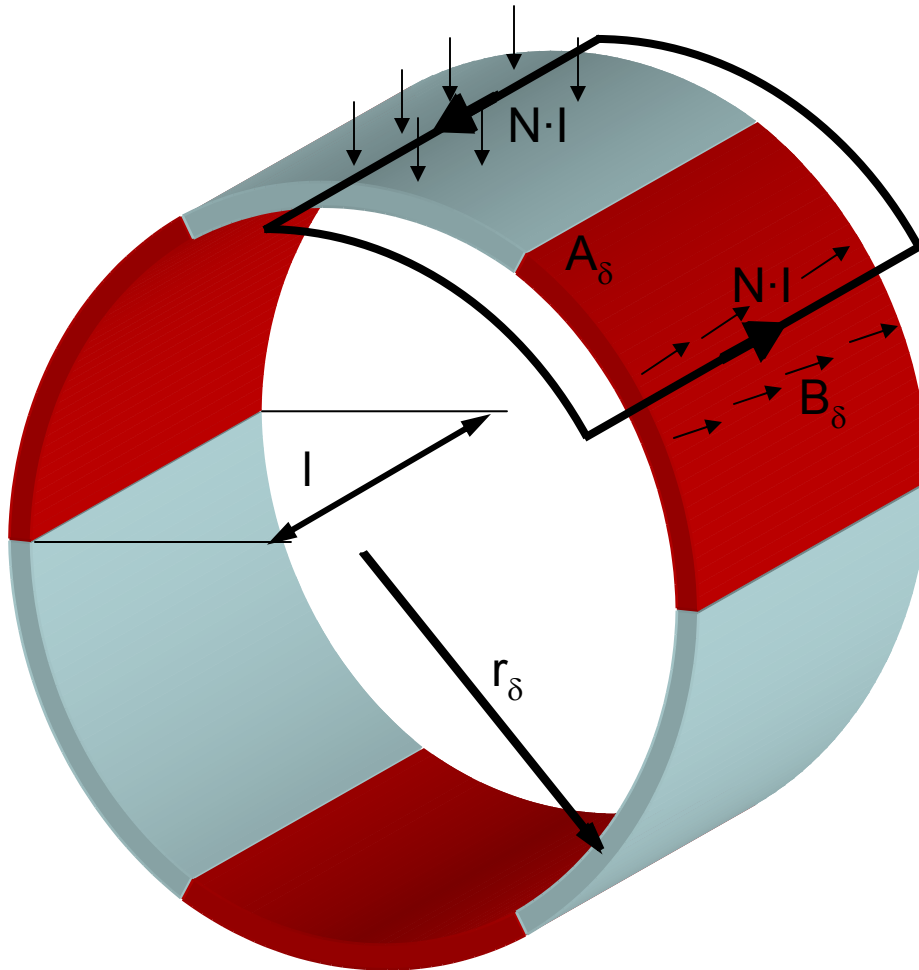

Torque

$$F = B_\delta \cdot N \cdot I \cdot l$$

$$T \approx 2p_p \cdot F \cdot r_\delta = 2p_p \cdot B_\delta \cdot N \cdot I \cdot l \cdot r_\delta$$

$$T \approx \frac{p_p}{\pi} \cdot B_\delta \cdot A_{\delta_\Sigma} \cdot N \cdot I \approx \Psi \cdot I$$

$$T \approx \frac{p_p}{\pi} \cdot B_\delta \cdot A_{\delta_\Sigma} \cdot A_{Cu} \cdot \sigma_{Cu}$$

Power

$$P = T \cdot \omega_m$$

$$P \approx \frac{p_p}{\pi} \cdot \omega_m \cdot B_\delta \cdot A_{\delta_\Sigma} \cdot A_{Cu} \cdot \sigma_{Cu}$$

$$P \approx \frac{1}{\pi} \cdot \omega_e \cdot B_\delta \cdot A_{\delta_\Sigma} \cdot A_{Cu} \cdot \sigma_{Cu} \approx U_i \cdot I$$

where

$$A_{\delta_\Sigma} = 2\pi \cdot l \cdot r_\delta$$

$$N \cdot I = A_{Cu} \cdot \sigma_{Cu}$$

## Motor/Generator Key Points

- ▶ Motor/Generator is used to boost the car performance and to recover the kinetic energy (peak operation)
- ▶ Motor/Generator must be therefore very small and powerful (not to carry unnecessary mass/space). It is designed to work at high electric frequency ( $\sim 1$  kHz) – high number of poles
- ▶ Such design requires high resolution PWM, both in time and amplitude
- ▶ Thus the advanced PWM peripheral (see further section) is key to design powerful electric motors

## 3-phase PMSM Model

- ▶ Considering sinusoidal 3-phase distributed winding and neglecting effect of magnetic saturation and leakage inductances

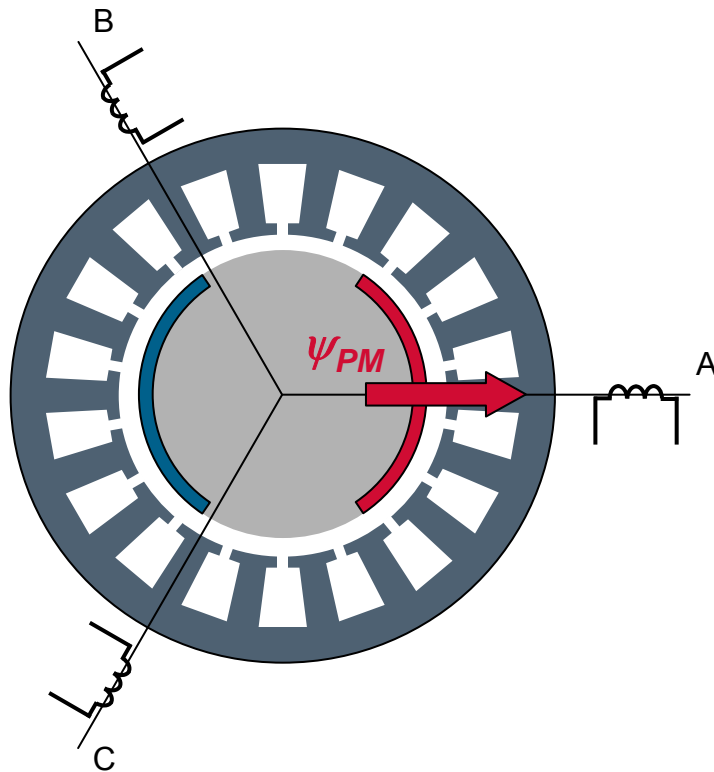

Stator voltage equations

$$\begin{bmatrix} u_A \\ u_B \\ u_C \end{bmatrix} = R_s \begin{bmatrix} i_A \\ i_B \\ i_C \end{bmatrix} + \frac{d}{dt} \begin{bmatrix} \psi_A \\ \psi_B \\ \psi_C \end{bmatrix}$$

Stator linkage flux

$$\begin{bmatrix} \psi_A \\ \psi_B \\ \psi_C \end{bmatrix} = \begin{bmatrix} L_{aa} & L_{ab} & L_{ac} \\ L_{ba} & L_{bb} & L_{bc} \\ L_{ca} & L_{cb} & L_{cc} \end{bmatrix} \begin{bmatrix} i_A \\ i_B \\ i_C \end{bmatrix} + \psi_{PM} \begin{bmatrix} \cos(\theta_e) \\ \cos\left(\theta_e - \frac{2}{3}\pi\right) \\ \cos\left(\theta_e + \frac{2}{3}\pi\right) \end{bmatrix}$$

Internal motor torque

$$T_i = \frac{P_i}{\omega_m} = \frac{p_p}{\omega_e} (u_{iA} i_A + u_{iB} i_B + u_{iC} i_C)$$

$$T_i = p_p \left( -\Psi_{PM} i_A \sin(\theta_e) - \Psi_{PM} i_B \sin\left(\theta_e - \frac{2}{3}\pi\right) - \Psi_{PM} i_C \sin\left(\theta_e + \frac{2}{3}\pi\right) \right)$$

# 3-phase PMSM Model

- ▶ Considering sinusoidal 3-phase distributed winding and neglecting effect of magnetic saturation and leakage inductances

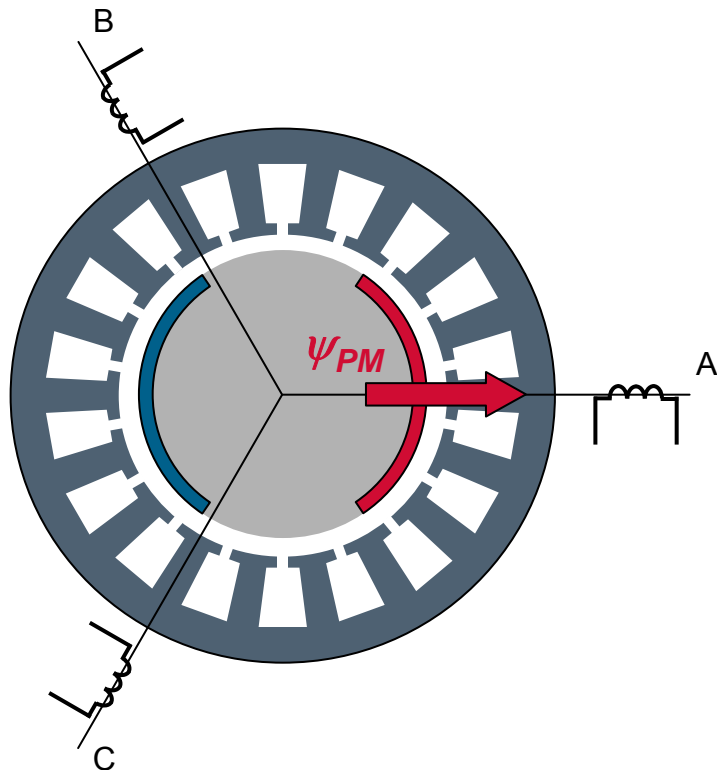

Stator voltage equations

$$\begin{bmatrix} u_A \\ u_B \\ u_C \end{bmatrix} = R \begin{bmatrix} i_A \\ i_B \\ i_C \end{bmatrix} + \frac{d}{dt} \begin{bmatrix} \psi_A \\ \psi_B \\ \psi_C \end{bmatrix}$$

Forward Clarke

Stator linkage flux

$$\begin{bmatrix} \psi_A \\ \psi_B \\ \psi_C \end{bmatrix} = \begin{bmatrix} L_{aa} & L_{ab} & L_{ac} \\ L_{ba} & L_{bb} & L_{bc} \\ L_{ca} & L_{cb} & L_{cc} \end{bmatrix} \begin{bmatrix} i_A \\ i_B \\ i_C \end{bmatrix} + \psi_{PM} \begin{bmatrix} \cos(\theta_e) \\ \cos\left(\theta_e - \frac{2}{3}\pi\right) \\ \cos\left(\theta_e + \frac{2}{3}\pi\right) \end{bmatrix}$$

Internal motor torque

$$T_i = \frac{P_i}{\omega_m} = \frac{p_p}{\omega_e} (u_{iA} i_A + u_{iB} i_B + u_{iC} i_C)$$

$$T_i = p_p \left( -\Psi_{PM} i_A \sin(\theta_e) - \Psi_{PM} i_B \sin\left(\theta_e - \frac{2}{3}\pi\right) - \Psi_{PM} i_C \sin\left(\theta_e + \frac{2}{3}\pi\right) \right)$$

## 2-phase PMSM Model

- ▶ Considering sinusoidal 2-phase distributed winding and neglecting effect of magnetic saturation and leakage inductances

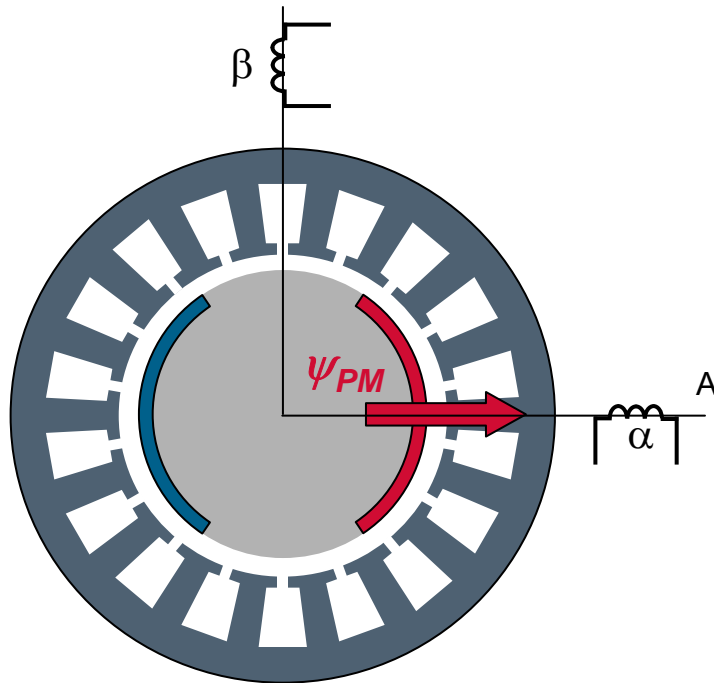

Stator voltage equations

$$\begin{bmatrix} u_\alpha \\ u_\beta \end{bmatrix} = R_s \begin{bmatrix} i_\alpha \\ i_\beta \end{bmatrix} + \frac{d}{dt} \begin{bmatrix} \psi_\alpha \\ \psi_\beta \end{bmatrix}$$

Stator linkage flux

$$\begin{bmatrix} \Psi_{S\alpha} \\ \Psi_{S\beta} \end{bmatrix} = \begin{bmatrix} L_S & 0 \\ 0 & L_S \end{bmatrix} \cdot \begin{bmatrix} i_\alpha \\ i_\beta \end{bmatrix} + \Psi_{PM}|_{i_{sd}=0} \cdot \begin{bmatrix} \cos \theta_{re} \\ \sin \theta_{re} \end{bmatrix}$$

Internal motor torque

$$T_i = \frac{3}{2} \frac{p_p}{\omega_e} (u_{i\alpha} i_\alpha + u_{i\beta} i_\beta) = \frac{3}{2} p_p (\Psi_\alpha i_\beta - \Psi_\beta i_\alpha)$$

## 2-phase PMSM Model

- ▶ Considering sinusoidal 2-phase distributed winding and neglecting effect of magnetic saturation and leakage inductances

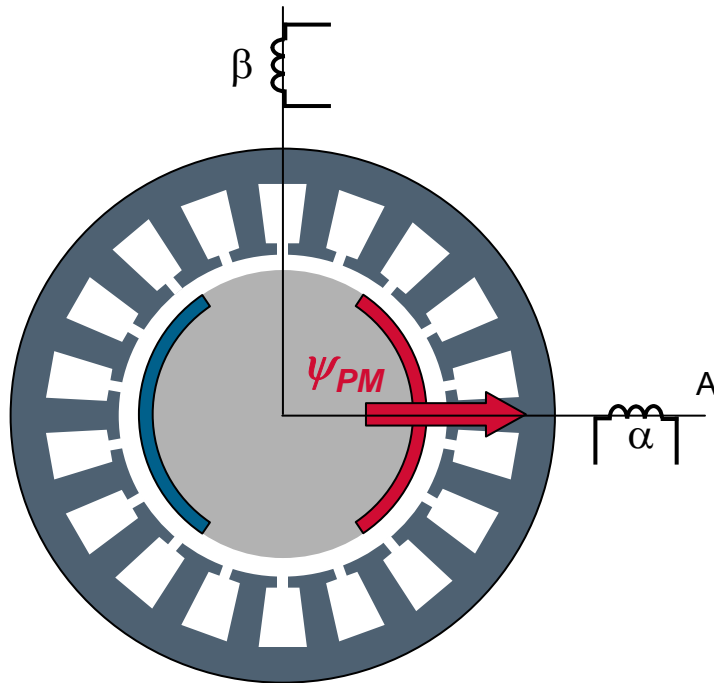

Stator voltage equations

$$\begin{bmatrix} u_\alpha \\ u_\beta \end{bmatrix} = R \begin{bmatrix} i_\alpha \\ i_\beta \end{bmatrix} + \frac{d}{dt} \begin{bmatrix} \psi_\alpha \\ \psi_\beta \end{bmatrix}$$

Forward Park

Stator linkage flux

$$\begin{bmatrix} \Psi_{S\alpha} \\ \Psi_{S\beta} \end{bmatrix} = \begin{bmatrix} L_S & 0 \\ 0 & L_S \end{bmatrix} \cdot \begin{bmatrix} i_\alpha \\ i_\beta \end{bmatrix} + \Psi_{PM} \Big|_{i_{sd}=0} \begin{bmatrix} \cos \theta_{re} \\ \sin \theta_{re} \end{bmatrix}$$

Internal motor torque

$$T_i = \frac{3}{2} \frac{p_p}{\omega_e} (u_{i\alpha} i_\alpha + u_{i\beta} i_\beta) = \frac{3}{2} p_p (\Psi_\alpha i_\beta - \Psi_\beta i_\alpha)$$

# Sinusoidal PM Motor Model in $dq$ Synchronous Frame

► Salient machine model in  $dq$  synchronous frame aligned with the rotor

- Stator Voltage Equations

$$\begin{bmatrix} u_d \\ u_q \end{bmatrix} = R_s \begin{bmatrix} i_d \\ i_q \end{bmatrix} + \begin{bmatrix} s & \omega_e \\ -\omega_e & s \end{bmatrix} \begin{bmatrix} \psi_d \\ \psi_q \end{bmatrix}$$

- Stator Flux Linkages of Salient Machine

$$\begin{bmatrix} \psi_d \\ \psi_q \end{bmatrix} = \begin{bmatrix} L_d & 0 \\ 0 & L_q \end{bmatrix} \begin{bmatrix} i_d \\ i_q \end{bmatrix} + \psi_{PM} \begin{bmatrix} 1 \\ 0 \end{bmatrix}$$

- Resulting stator voltage equations

$$\begin{bmatrix} u_d \\ u_q \end{bmatrix} = R_s \begin{bmatrix} i_d \\ i_q \end{bmatrix} + \begin{bmatrix} sL_d & 0 \\ 0 & sL_q \end{bmatrix} \begin{bmatrix} i_d \\ i_q \end{bmatrix} + \omega_e \begin{bmatrix} -L_q \\ L_d \end{bmatrix} \begin{bmatrix} i_q \\ i_d \end{bmatrix} + \omega_e \psi_{PM} \begin{bmatrix} 0 \\ 1 \end{bmatrix}$$

- Internal motor torque

$$T_i = \frac{3}{2} \frac{p_p}{\omega_e} (u_{id} i_d + u_{iq} i_q) = \frac{3}{2} p_p (\Psi_d i_q - \Psi_q i_d) = \frac{3}{2} p_p \cdot \Psi_{PM} i_q$$

# Sinusoidal PM Motor Model in $dq$ Synchronous Frame

► Salient machine model in  $dq$  synchronous frame aligned with the rotor

- Stator Voltage Equations

$$\begin{bmatrix} u_d \\ u_q \end{bmatrix} = R_s \begin{bmatrix} i_d \\ i_q \end{bmatrix} + \begin{bmatrix} s & \omega_e \\ -\omega_e & s \end{bmatrix} \begin{bmatrix} \psi_d \\ \psi_q \end{bmatrix}$$

- Stator Flux Linkages of Salient Machine

$$\begin{bmatrix} \psi_d \\ \psi_q \end{bmatrix} = \begin{bmatrix} L_d & 0 \\ 0 & L_q \end{bmatrix} \begin{bmatrix} i_d \\ i_q \end{bmatrix} + \psi_{PM} \begin{bmatrix} 1 \\ 0 \end{bmatrix}$$

- Resulting stator voltage equations

$$\begin{bmatrix} u_d \\ u_q \end{bmatrix} = R_s \begin{bmatrix} i_d \\ i_q \end{bmatrix} + \begin{bmatrix} sL_d & 0 \\ 0 & sL_q \end{bmatrix} \begin{bmatrix} i_d \\ i_q \end{bmatrix} + \omega_e \begin{bmatrix} -L_q \\ L_d \end{bmatrix} \begin{bmatrix} i_q \\ i_d \end{bmatrix} + \omega_e \psi_{PM} \begin{bmatrix} 0 \\ 1 \end{bmatrix}$$

R-L circuit

- Internal motor torque

$$T_i = \frac{3}{2} \frac{p_p}{\omega_e} (u_{id} i_d + u_{iq} i_q) = \frac{3}{2} p_p (\Psi_d i_q - \Psi_q i_d) = \frac{3}{2} p_p \cdot \Psi_{PM} i_q$$

# Sinusoidal PM Motor Model in $dq$ Synchronous Frame

► Salient machine model in  $dq$  synchronous frame aligned with the rotor

- Stator Voltage Equations

$$\begin{bmatrix} u_d \\ u_q \end{bmatrix} = R_s \begin{bmatrix} i_d \\ i_q \end{bmatrix} + \begin{bmatrix} s & \omega_e \\ -\omega_e & s \end{bmatrix} \begin{bmatrix} \psi_d \\ \psi_q \end{bmatrix}$$

- Stator Flux Linkages of Salient Machine

$$\begin{bmatrix} \psi_d \\ \psi_q \end{bmatrix} = \begin{bmatrix} L_d & 0 \\ 0 & L_q \end{bmatrix} \begin{bmatrix} i_d \\ i_q \end{bmatrix} + \psi_{PM} \begin{bmatrix} 1 \\ 0 \end{bmatrix}$$

- Resulting stator voltage equations

$$\begin{bmatrix} u_d \\ u_q \end{bmatrix} = R_s \begin{bmatrix} i_d \\ i_q \end{bmatrix} + \begin{bmatrix} sL_d & 0 \\ 0 & sL_q \end{bmatrix} \begin{bmatrix} i_d \\ i_q \end{bmatrix} + \omega_e \begin{bmatrix} -L_q \\ L_d \end{bmatrix} \begin{bmatrix} i_q \\ i_d \end{bmatrix} + \omega_e \psi_{PM} \begin{bmatrix} 0 \\ 1 \end{bmatrix}$$

R-L circuit

cross-coupling

- Internal motor torque

$$T_i = \frac{3}{2} \frac{p_p}{\omega_e} (u_{id} i_d + u_{iq} i_q) = \frac{3}{2} p_p (\Psi_d i_q - \Psi_q i_d) = \frac{3}{2} p_p \cdot \Psi_{PM} i_q$$

# Sinusoidal PM Motor Model in $dq$ Synchronous Frame

► Salient machine model in  $dq$  synchronous frame aligned with the rotor

- Stator Voltage Equations

$$\begin{bmatrix} u_d \\ u_q \end{bmatrix} = R_s \begin{bmatrix} i_d \\ i_q \end{bmatrix} + \begin{bmatrix} s & \omega_e \\ -\omega_e & s \end{bmatrix} \begin{bmatrix} \psi_d \\ \psi_q \end{bmatrix}$$

- Stator Flux Linkages of Salient Machine

$$\begin{bmatrix} \psi_d \\ \psi_q \end{bmatrix} = \begin{bmatrix} L_d & 0 \\ 0 & L_q \end{bmatrix} \begin{bmatrix} i_d \\ i_q \end{bmatrix} + \psi_{PM} \begin{bmatrix} 1 \\ 0 \end{bmatrix}$$

- Resulting stator voltage equations

$$\begin{bmatrix} u_d \\ u_q \end{bmatrix} = R_s \begin{bmatrix} i_d \\ i_q \end{bmatrix} + \begin{bmatrix} sL_d & 0 \\ 0 & sL_q \end{bmatrix} \begin{bmatrix} i_d \\ i_q \end{bmatrix} + \omega_e \begin{bmatrix} -L_q \\ L_d \end{bmatrix} \begin{bmatrix} i_q \\ i_d \end{bmatrix} + \omega_e \psi_{PM} \begin{bmatrix} 0 \\ 1 \end{bmatrix}$$

R-L circuit

cross-coupling back-EMF

- Internal motor torque

$$T_i = \frac{3}{2} \frac{p_p}{\omega_e} (u_{id} i_d + u_{iq} i_q) = \frac{3}{2} p_p (\Psi_d i_q - \Psi_q i_d) = \frac{3}{2} p_p \cdot \Psi_{PM} i_q$$

# Field Weakening - Why Is It Needed?

- ▶ For given strength of the rotor magnetic field there is point (base speed) where external voltage ( $U_{dc}$ ) can not “push” any more current “into” the el. motor against the back-EMF ( $U_i$ ).
- ▶ Spinning el. motor above the “base speed” requires to lower the back-EMF ( $U_i$ ) by weakening the rotor magnetic field.

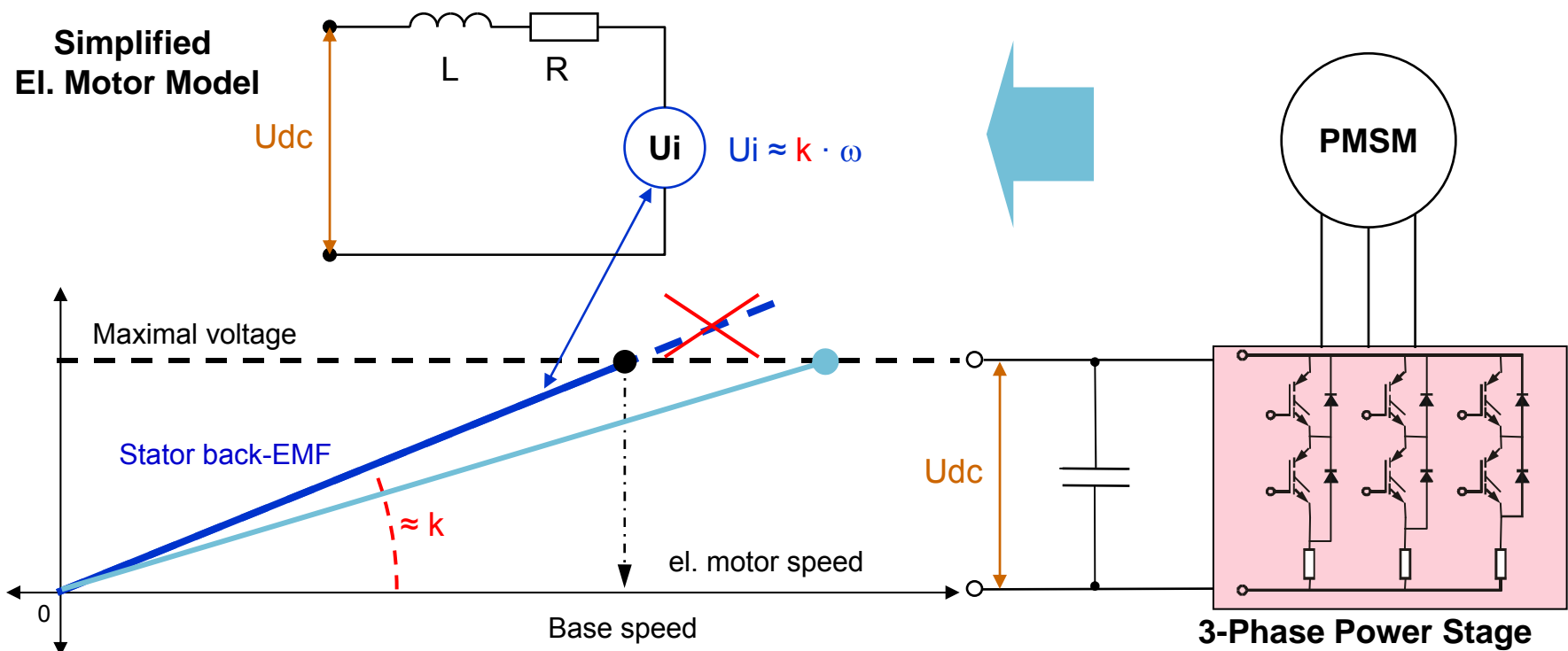

# PMSM Field Weakening

- ▶ Required to get above motor base speed, where voltage capacity to overcome the back-EMF starts to be limited
  - ▶ Makes the rotor magnetic field “weaker” in order to lower back-EMF voltage induced in the stator winding
  - ▶ For PM motors FW means to apply opposite magnetic field to the permanent magnets (since PM rotates this FW field has to rotate as well).
- Note: the FW changes the angle between the stator and the rotor magnetic fluxes (in d, q rotor related coordinates)

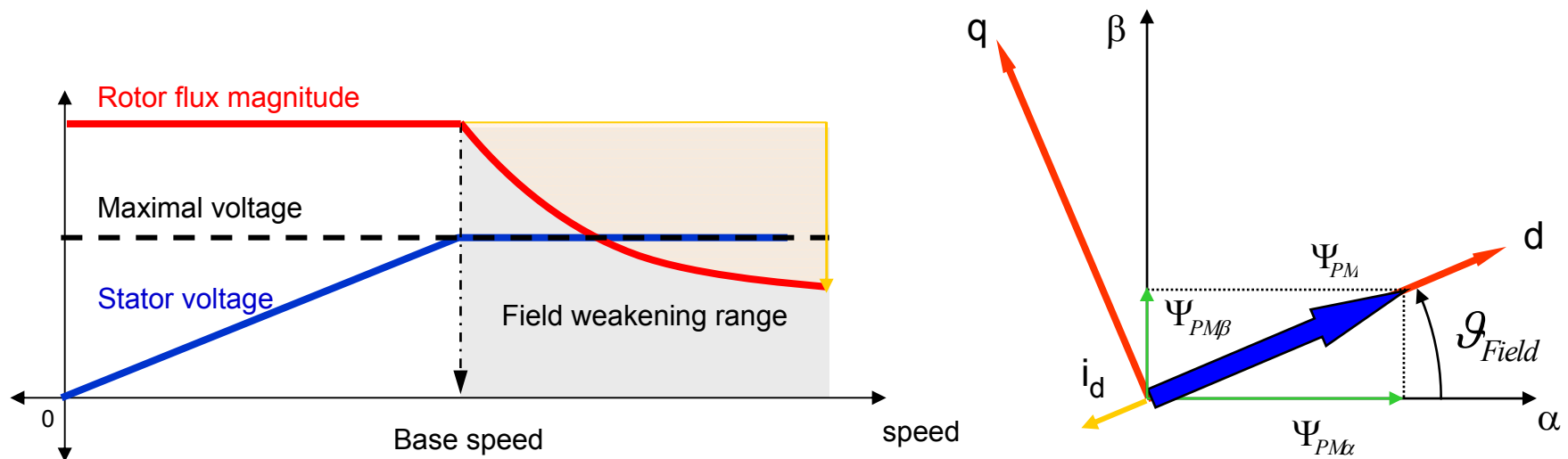

# PM Demagnetization Characteristic

PM -typical hysteresis loop in both normal and intrinsic forms

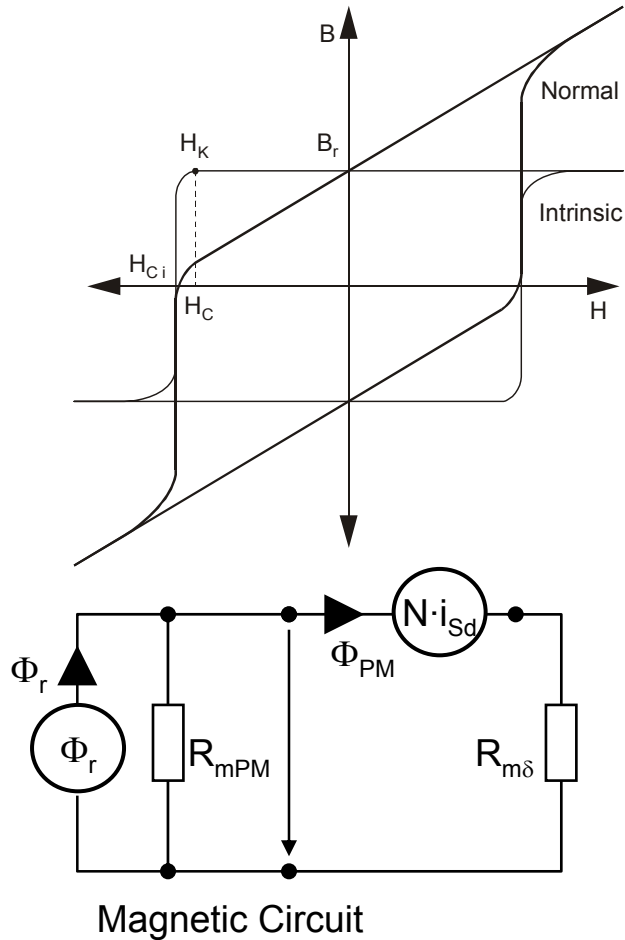

PM Demagnetization Characteristic

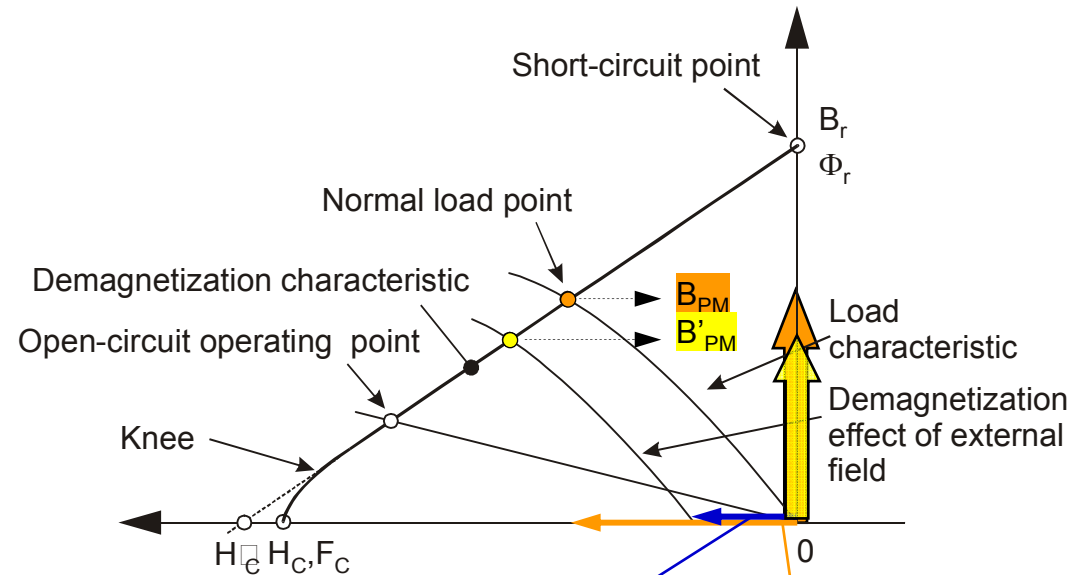

Model for linear region  
( $0 > H > H_K$ )

$$B_{PM} = B_r + \mu_{rec} \cdot H$$

$$\Phi_{PM} = \Phi_r \frac{R_{mPM}}{\sum R_m} - \frac{N \cdot i_{fw}}{\sum R_m} = \frac{-H'_C \cdot l_{PM}}{\sum R_m} - \frac{N \cdot i_{fw}}{\sum R_m}$$

$$\frac{N \cdot i_{Sd}}{l_{PM}}$$

$$H_{PM} = \frac{1}{\mu_{rec}} (B_{PM} - B_r)$$

# Static Sine PMSM Motor Model

## ► Static Machine Model in d-q rotating frame

- Stator Voltage Equations

$$\begin{bmatrix} u_{Sd} \\ u_{Sq} \end{bmatrix} = \begin{bmatrix} R_S & 0 \\ 0 & R_S \end{bmatrix} \cdot \begin{bmatrix} i_{Sd} \\ i_{Sq} \end{bmatrix} + \begin{bmatrix} 0 & -\omega_{re} \\ \omega_{re} & 0 \end{bmatrix} \cdot \begin{bmatrix} \Psi_{Sd} \\ \Psi_{Sq} \end{bmatrix} \quad s = \frac{d}{dt} = 0$$

- Stator Flux Linkages

$$\begin{bmatrix} \Psi_{Sd} \\ \Psi_{Sq} \end{bmatrix} = \begin{bmatrix} L_S & 0 \\ 0 & L_S \end{bmatrix} \cdot \begin{bmatrix} i_{Sd} \\ i_{Sq} \end{bmatrix} + \Psi_{PM} \Big|_{i_{Sd}=0} \cdot \begin{bmatrix} 1 \\ 0 \end{bmatrix}$$

- Stator equations for non field weakening ( $i_{Sd} = 0$ )

$$u_{Sd} = R_S \cdot i_{Sd} - \omega_{re} \cdot \Psi_{Sq} = -\omega_{re} \cdot L_S \cdot i_{Sq}$$

$$u_{Sq} = R_S \cdot i_{Sq} + \omega_{re} \cdot \Psi_{Sd} = R_S \cdot i_{Sq} + \omega_{re} \cdot \Psi_{PM0}$$

- Stator equations for non field weakening ( $i_{Sd} = -i_{fw}$ )

$$u_{Sd} = R_S \cdot i_{Sd} - \omega_{re} \cdot \Psi_{Sq} = -R_S \cdot i_{fw} - \omega_{re} \cdot L_S \cdot i_{Sq}$$

$$u_{Sq} = R_S \cdot i_{Sq} + \omega_{re} \cdot \Psi_{Sd} = R_S \cdot i_{Sq} - \omega_{re} \cdot L_S \cdot i_{fw} + \omega_{re} \cdot \Psi_{PM0}$$

reduced  $U_i$  by increased  $i_{fw}$

# Torque of PMSM

## ► Torque Model in d-q rotating frame

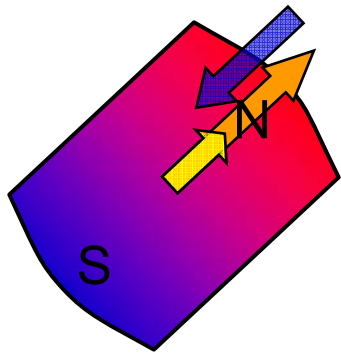

$$\psi_d = \psi_{PM0} = konst.$$

$$T_i = \frac{3}{2} p_p \cdot \Psi_{PM0} \cdot i_q$$

Below nominal speed

$$\psi_d = \Psi_{PM0} - L_s \cdot i_{Sd} \neq konst.$$

$$T_i = \frac{3}{2} p_p \cdot \Psi_{PM0} \cdot i_q$$

Above nominal speed

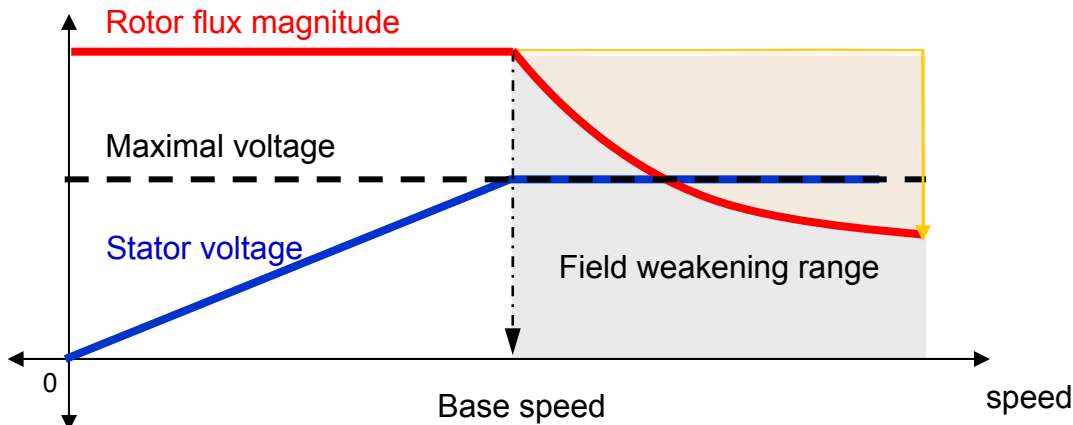

**Torque constant is not reduced !**

$$I_{\max} = \sqrt{i_{Sd}^2 + i_{Sq}^2}$$

$$T_i = \frac{3}{2} p_p \cdot \Psi_{PM0} \cdot \sqrt{I_{\max}^2 - i_{Sd}^2}$$

**Torque ( $i_q$ ) is reduced !**

# Natural Limitations of the Control

- ▶ Available voltage amplitude is limited by used type of power stage.
- ▶ Phase current amplitude is limited by capabilities of power devices and motor thermal design.

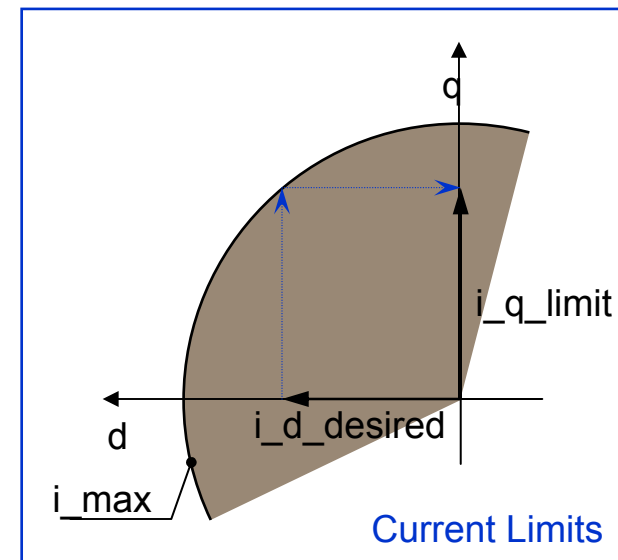
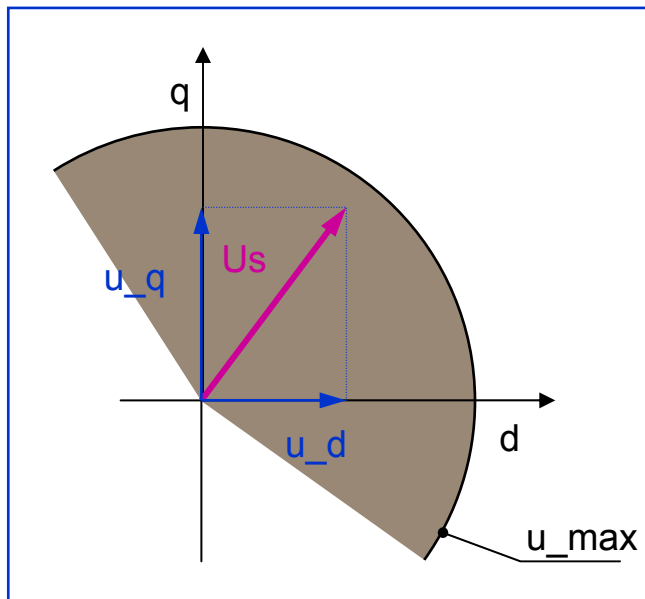
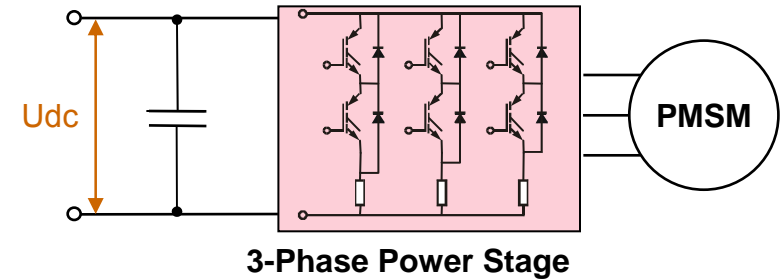

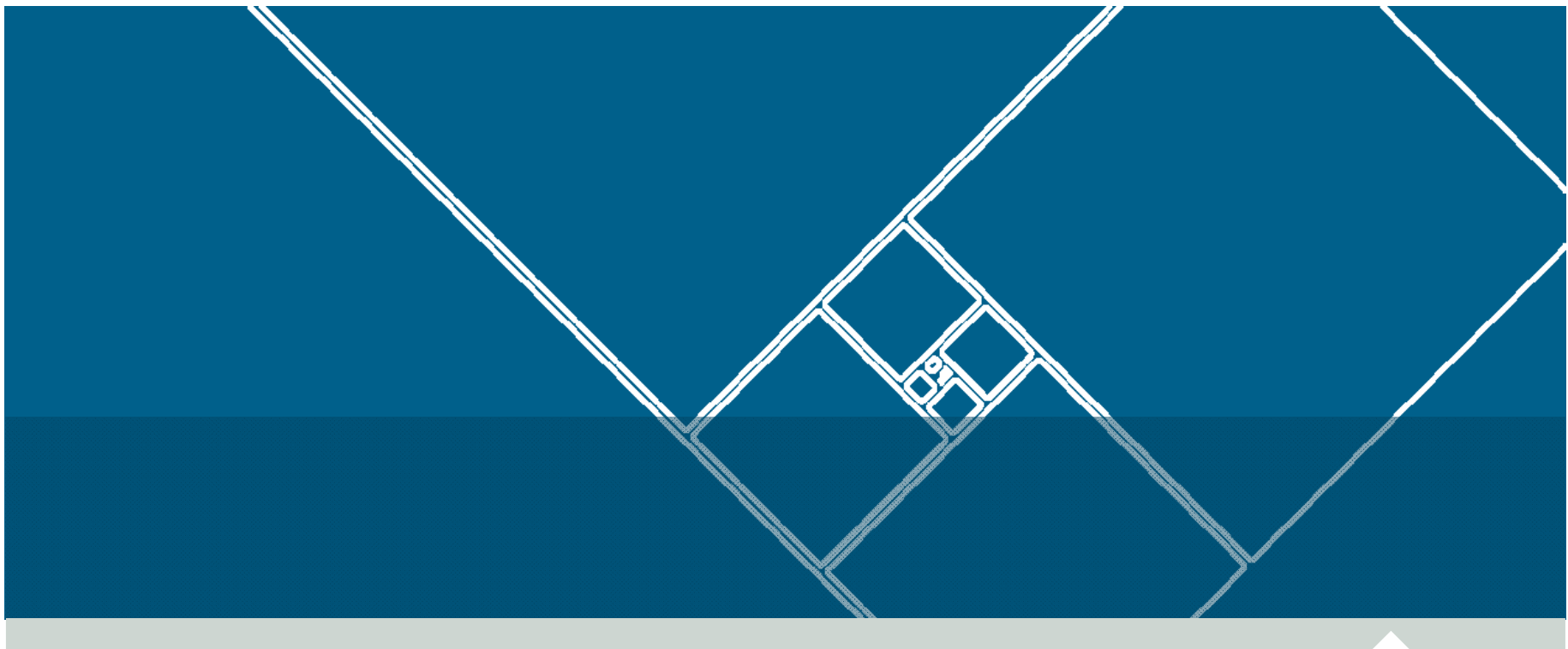

# KERS Control Unit

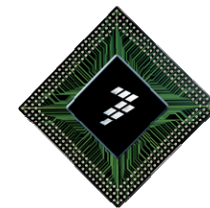

# KERS Energy/Power Flow

## ► Main KCU tasks:

- control energy flow in the system
- control eMotor
- monitor ESS
- command DC/DC

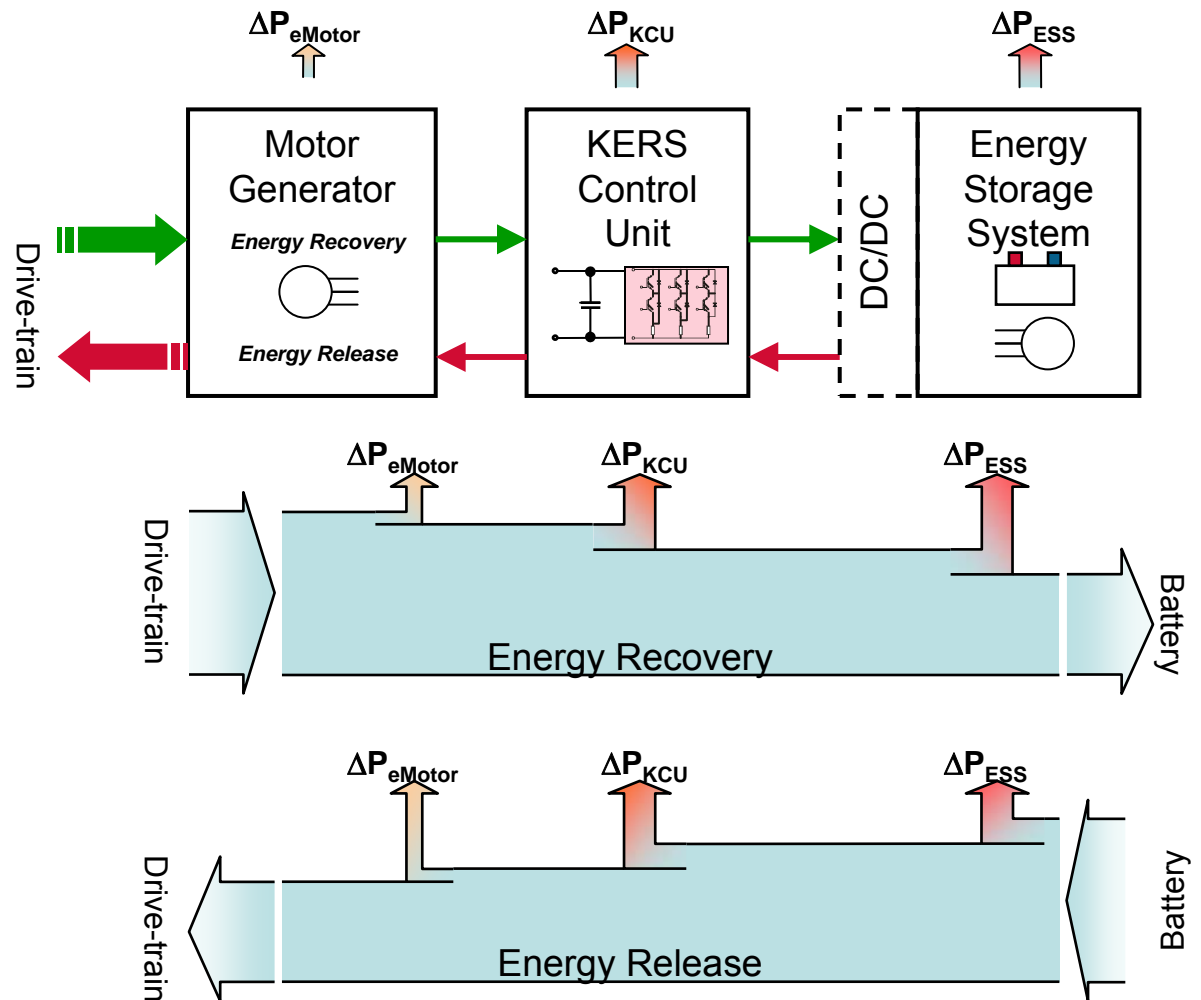

# Fast and Precise Control — FOC

## ► Motor Control – Field Oriented Control (FOC)

- The PI controllers operate in the d-q reference frame of the rotor, they are isolated from the sinusoidal variation of motor currents and voltages and therefore perform equally well at low and high speeds.  $i_q$  is made to equal the Torque Command, while  $i_d$  is equal to zero which allows motors, when operating below base speed, to produce the rated torque at any speed. When  $i_d$  is not equal to zero then the motor is in Field Weakening, operating above the base speed, where the maximum torque is reduced with increase speed.

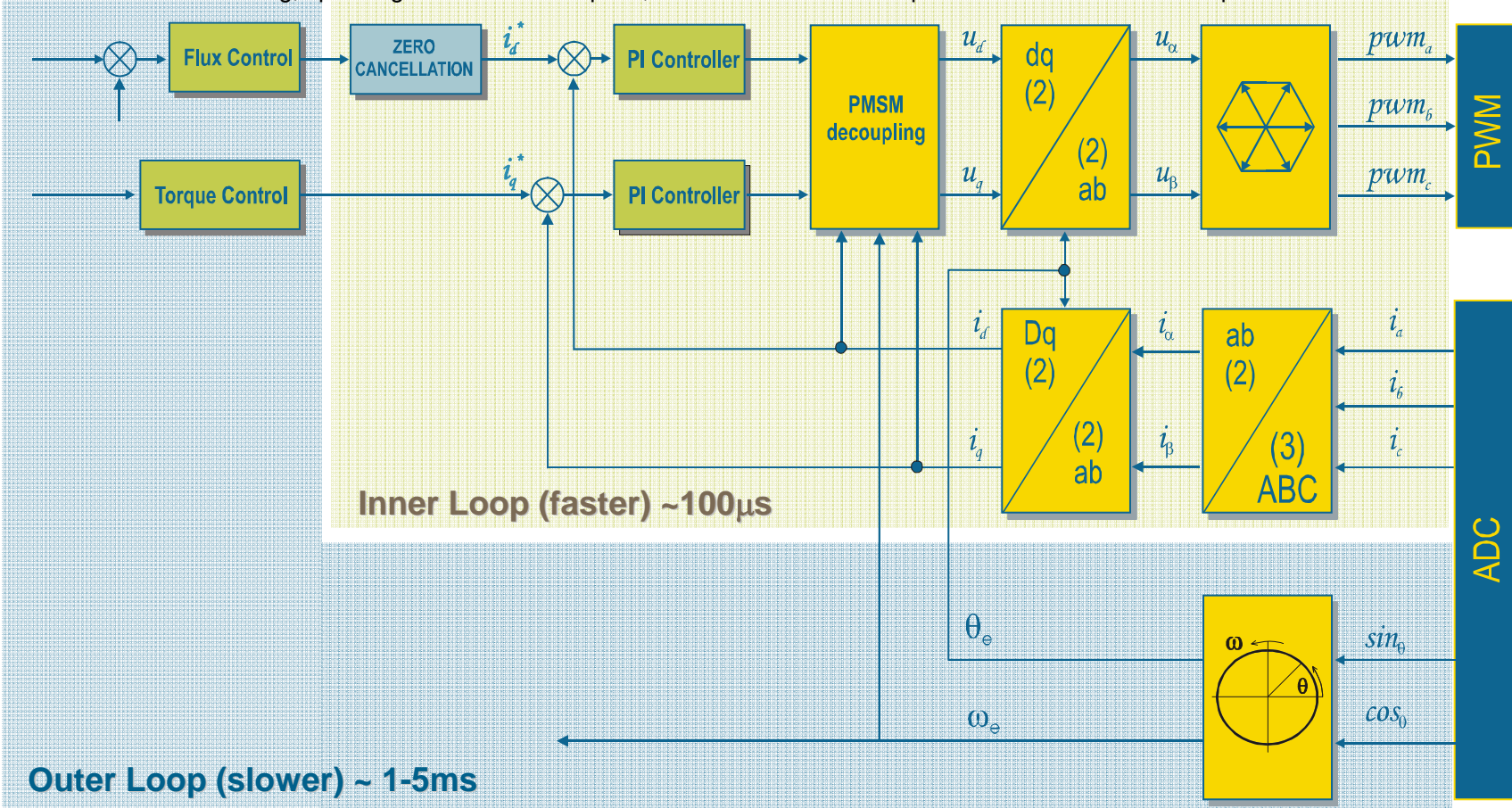

# FOC Transformation Sequencing

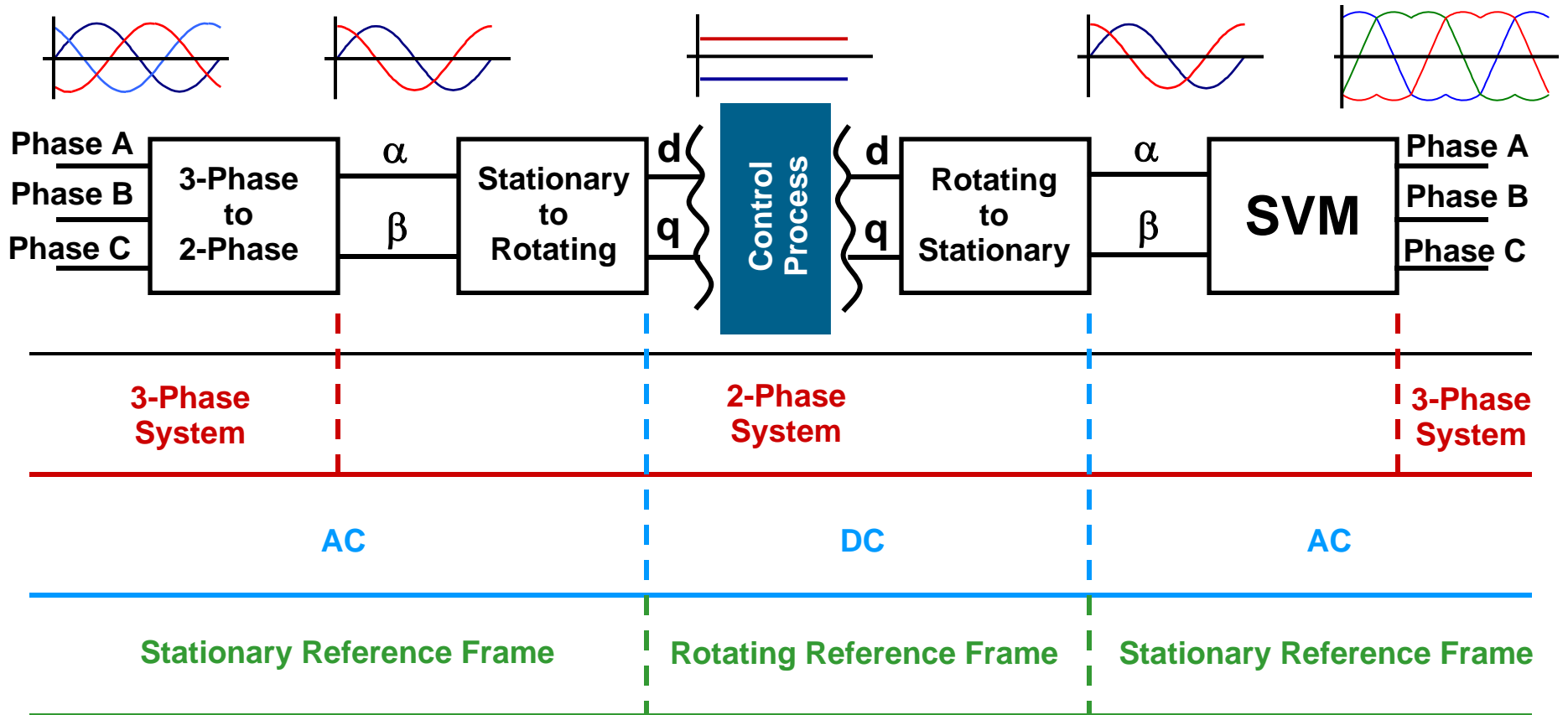

# FOC Transformation Sequencing

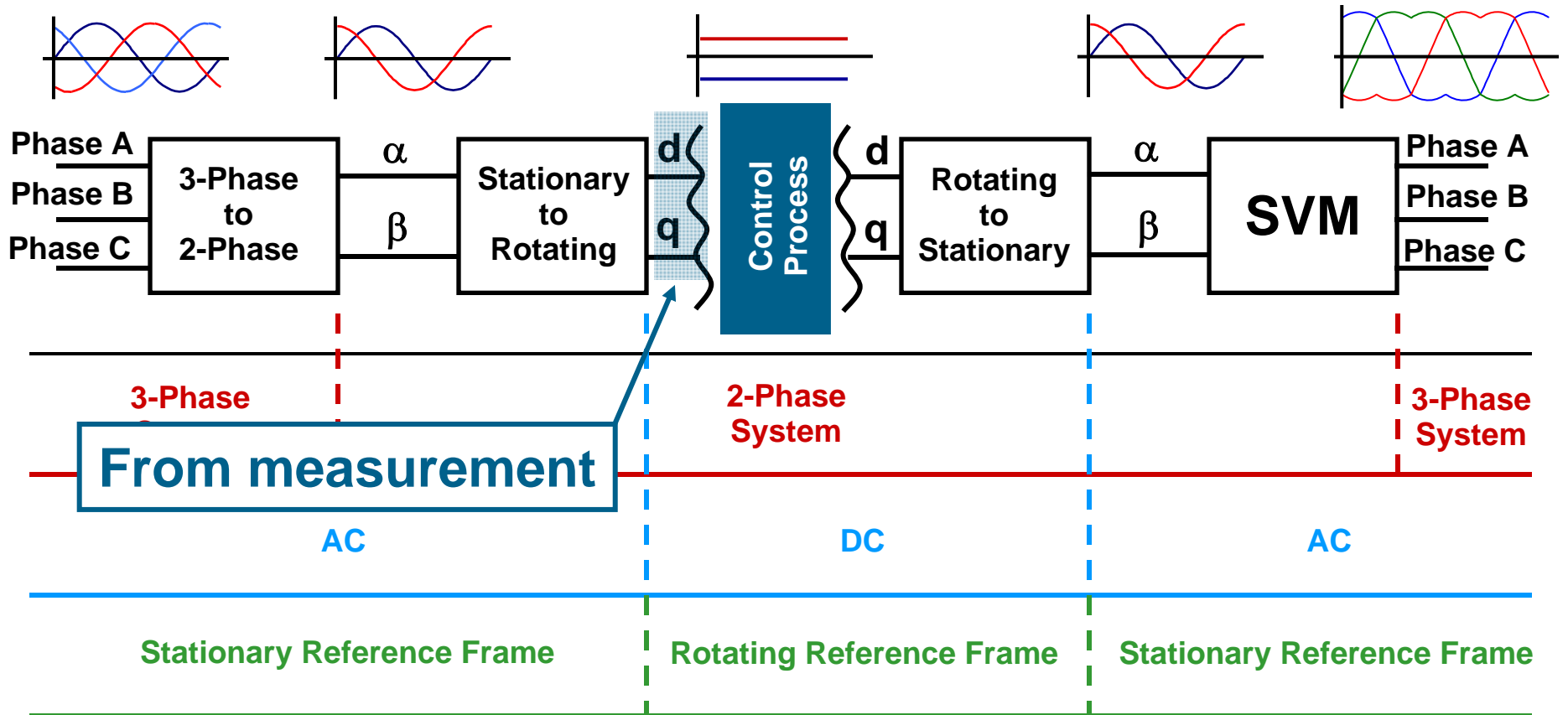

# FOC Transformation Sequencing

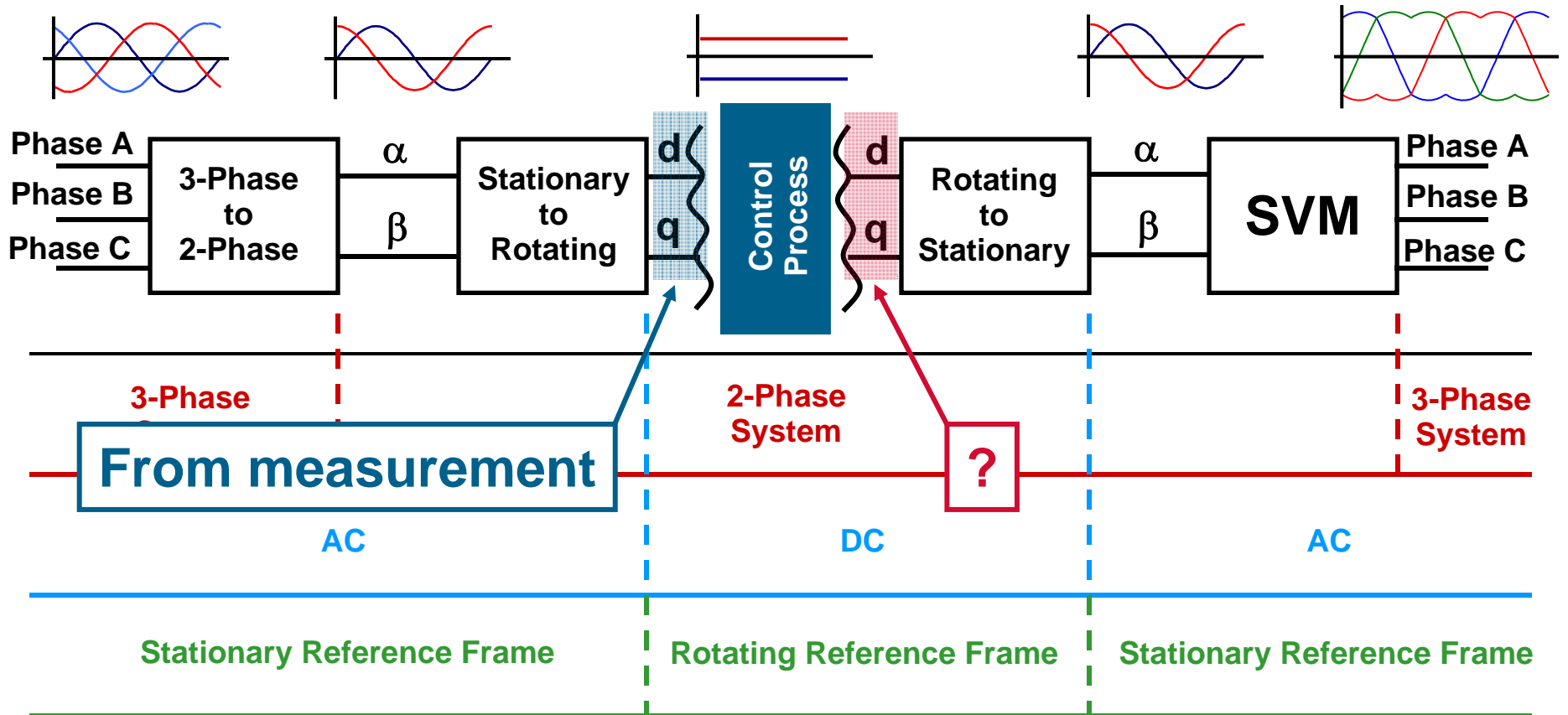

# PMSM Current Control

$$\begin{bmatrix} u_d \\ u_q \end{bmatrix} = R_s \begin{bmatrix} i_d \\ i_q \end{bmatrix} + \begin{bmatrix} sL_d & 0 \\ 0 & sL_q \end{bmatrix} \begin{bmatrix} i_d \\ i_q \end{bmatrix} + \omega_e \begin{bmatrix} -L_q \\ L_d \end{bmatrix} \begin{bmatrix} i_q \\ i_d \end{bmatrix} + \omega_e \psi_{PM} \begin{bmatrix} 0 \\ 1 \end{bmatrix}$$

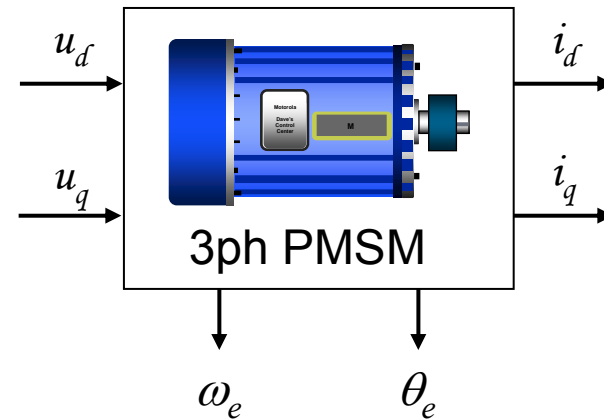

# PMSM Current Control

$$\begin{bmatrix} u_d \\ u_q \end{bmatrix} = R_s \begin{bmatrix} i_d \\ i_q \end{bmatrix} + \begin{bmatrix} sL_d & 0 \\ 0 & sL_q \end{bmatrix} \begin{bmatrix} i_d \\ i_q \end{bmatrix} + \omega_e \begin{bmatrix} -L_q \\ L_d \end{bmatrix} \begin{bmatrix} i_q \\ i_d \end{bmatrix} + \omega_e \psi_{PM} \begin{bmatrix} 0 \\ 1 \end{bmatrix}$$

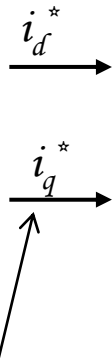

Two axis components of  
required current vector

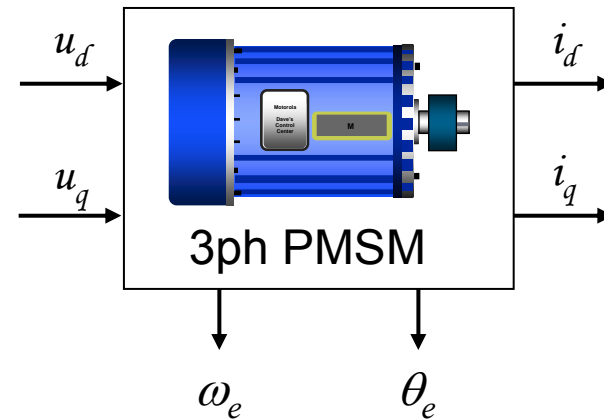

# PMSM Current Control

$$\begin{bmatrix} u_d \\ u_q \end{bmatrix} = R_s \begin{bmatrix} i_d \\ i_q \end{bmatrix} + \begin{bmatrix} sL_d & 0 \\ 0 & sL_q \end{bmatrix} \begin{bmatrix} i_d \\ i_q \end{bmatrix} + \omega_e \begin{bmatrix} -L_q \\ L_d \end{bmatrix} \begin{bmatrix} i_q \\ i_d \end{bmatrix} + \omega_e \psi_{PM} \begin{bmatrix} 0 \\ 1 \end{bmatrix}$$

back-EMF

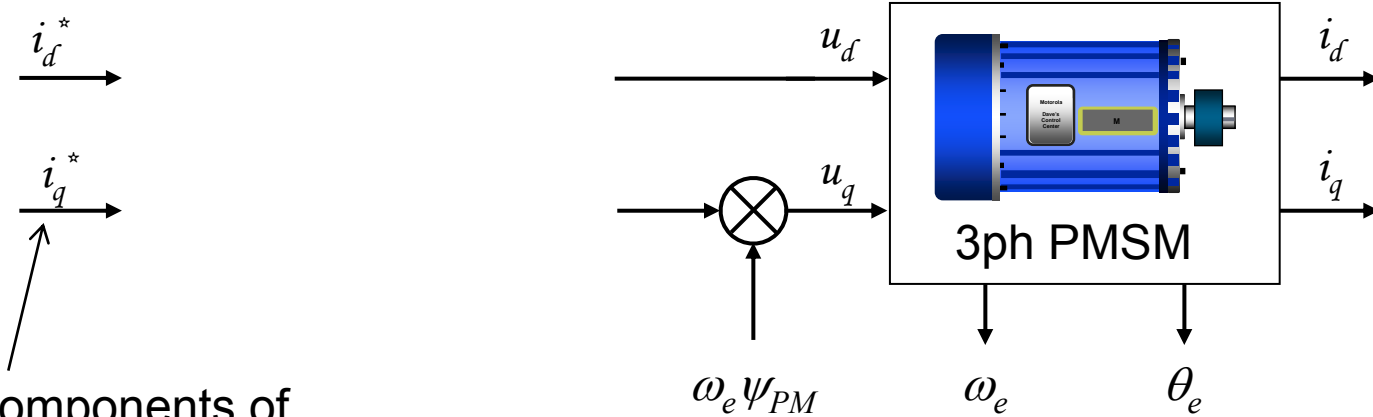

Two axis components of required current vector

# PMSM Current Control

$$\begin{bmatrix} u_d \\ u_q \end{bmatrix} = R_s \begin{bmatrix} i_d \\ i_q \end{bmatrix} + \begin{bmatrix} sL_d & 0 \\ 0 & sL_q \end{bmatrix} \begin{bmatrix} i_d \\ i_q \end{bmatrix} + \omega_e \begin{bmatrix} -L_q \\ L_d \end{bmatrix} \begin{bmatrix} i_q \\ i_d \end{bmatrix} + \omega_e \psi_{PM} \begin{bmatrix} 0 \\ 1 \end{bmatrix}$$

cross-coupling back-EMF

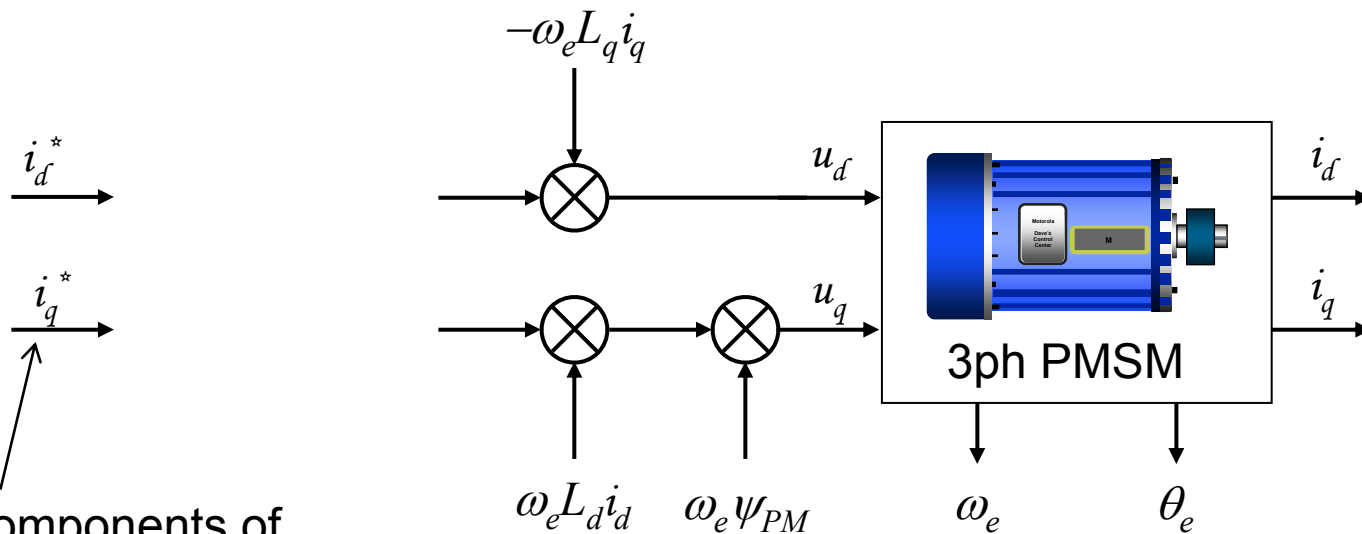

Two axis components of required current vector

# PMSM Current Control

$$\begin{bmatrix} u_d \\ u_q \end{bmatrix} = R_s \begin{bmatrix} i_d \\ i_q \end{bmatrix} + \begin{bmatrix} sL_d & 0 \\ 0 & sL_q \end{bmatrix} \begin{bmatrix} i_d \\ i_q \end{bmatrix} + \omega_e \begin{bmatrix} -L_q \\ L_d \end{bmatrix} \begin{bmatrix} i_q \\ i_d \end{bmatrix} + \omega_e \psi_{PM} \begin{bmatrix} 0 \\ 1 \end{bmatrix}$$

R-L circuit      cross-coupling back-EMF

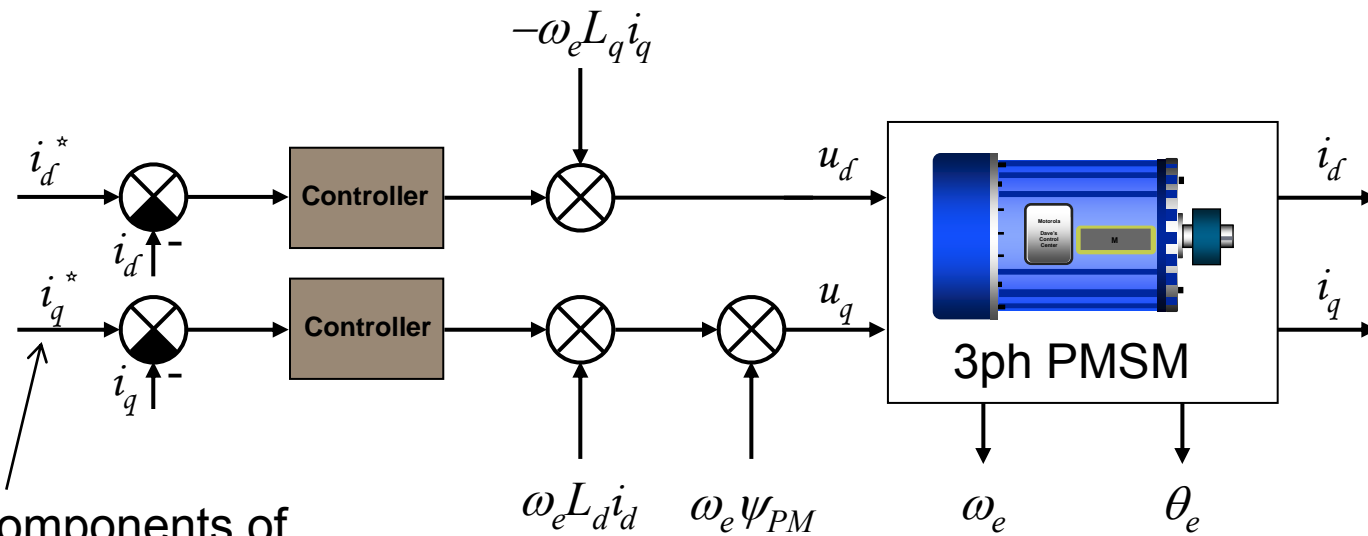

Two axis components of required current vector

# PMSM Current Control

$$\begin{bmatrix} u_d \\ u_q \end{bmatrix} = R_s \begin{bmatrix} i_d \\ i_q \end{bmatrix} + \begin{bmatrix} sL_d & 0 \\ 0 & sL_q \end{bmatrix} \begin{bmatrix} i_d \\ i_q \end{bmatrix} + \omega_e \begin{bmatrix} -L_q \\ L_d \end{bmatrix} \begin{bmatrix} i_q \\ i_d \end{bmatrix} + \omega_e \psi_{PM} \begin{bmatrix} 0 \\ 1 \end{bmatrix}$$

R-L circuit      cross-coupling back-EMF

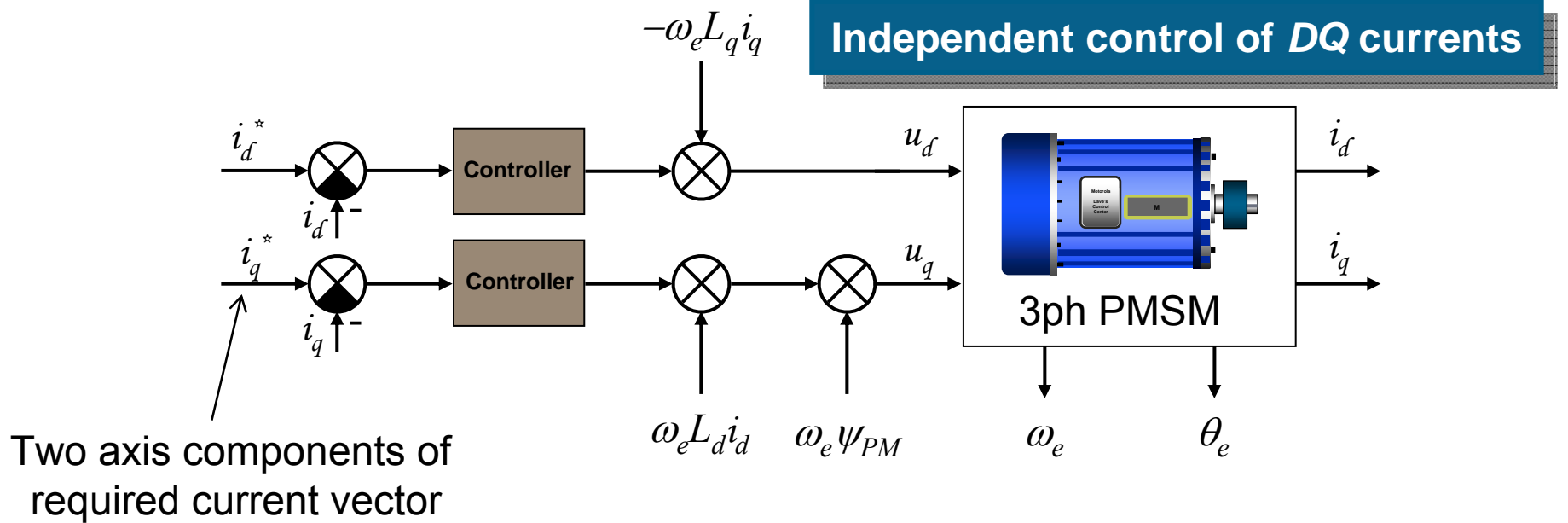

# PMSM Current Control

$$\begin{bmatrix} u_d \\ u_q \end{bmatrix} = R_s \begin{bmatrix} i_d \\ i_q \end{bmatrix} + \begin{bmatrix} sL_d & 0 \\ 0 & sL_q \end{bmatrix} \begin{bmatrix} i_d \\ i_q \end{bmatrix} + \omega_e \begin{bmatrix} -L_q \\ L_d \end{bmatrix} \begin{bmatrix} i_q \\ i_d \end{bmatrix} + \omega_e \psi_{PM} \begin{bmatrix} 0 \\ 1 \end{bmatrix}$$

R-L circuit      cross-coupling back-EMF

## Independent control of *DQ* currents

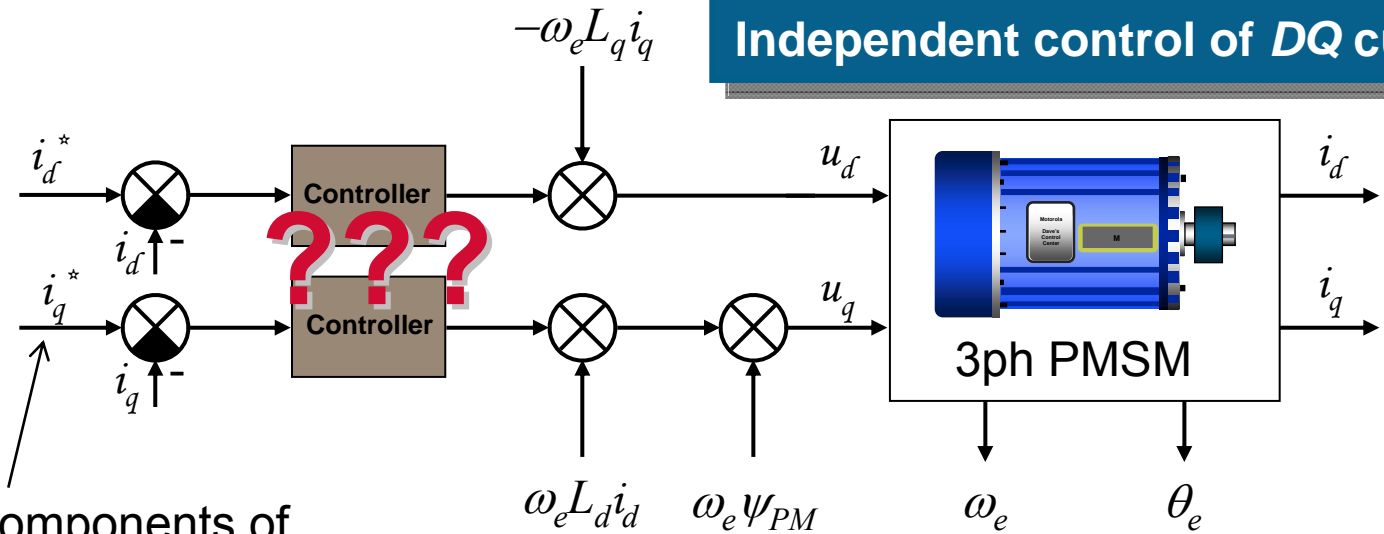

Two axis components of required current vector

# PI Controller Gain Calculation

- ▶ Implementation of zero Cancellation allows precise matching of characteristic polynomial coefficients
- ▶ Enables simple tuning of the current loop bandwidth and attenuation

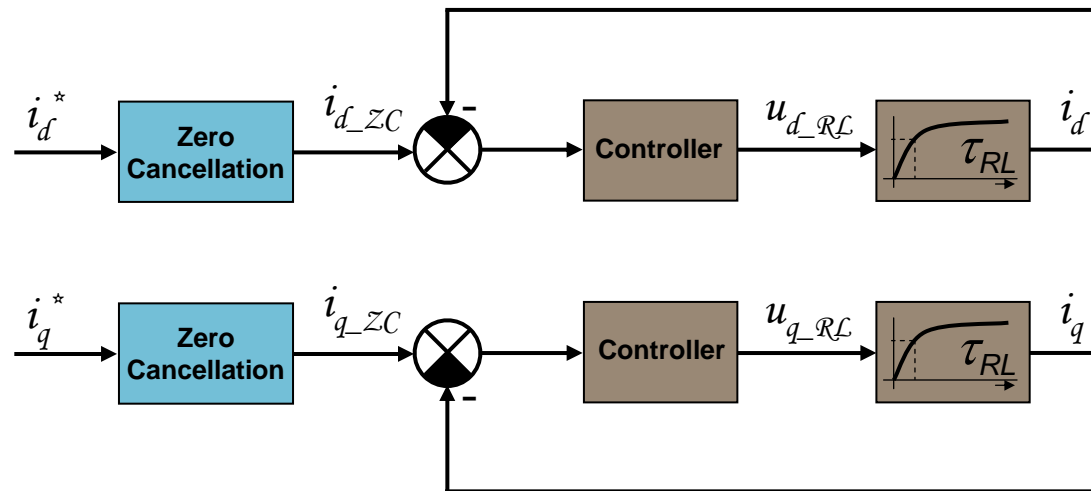

## PI controller gains

$$K_P = 2\xi\omega_0L - R$$

$$K_I = \omega_0^2L$$

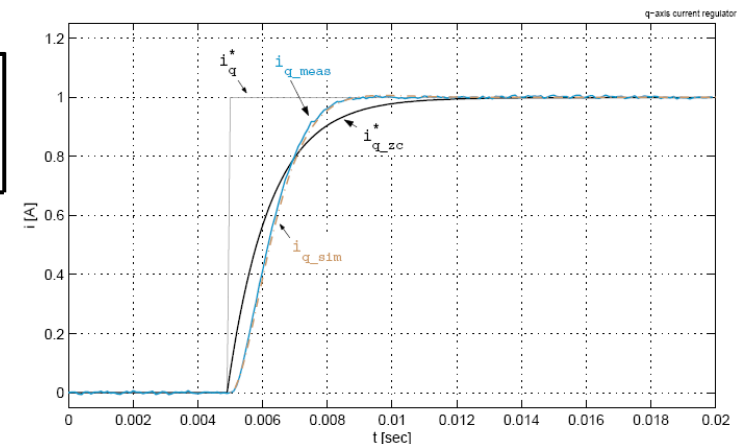

# Natural Limitations of the Control

- ▶ Available voltage amplitude is limited by used type of power stage
- ▶ Phase current amplitude is limited by capabilities of power devices and motor thermal design

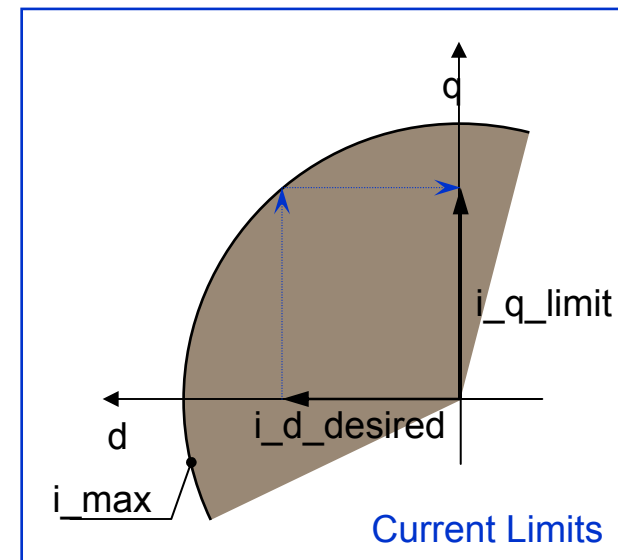
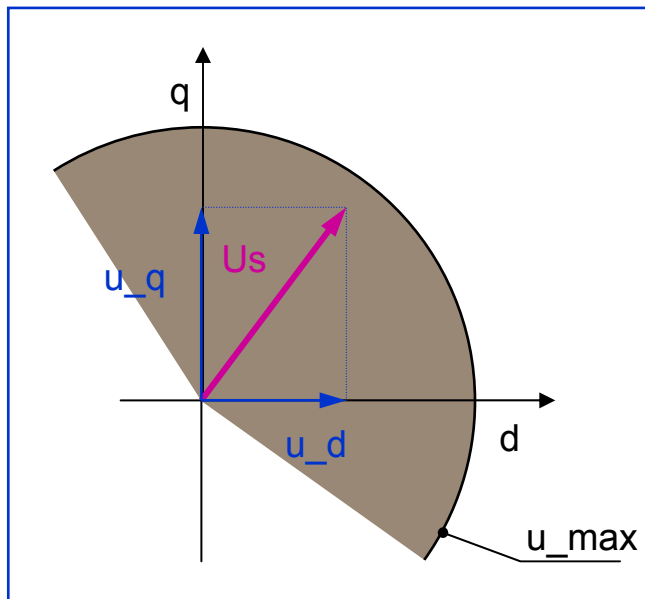
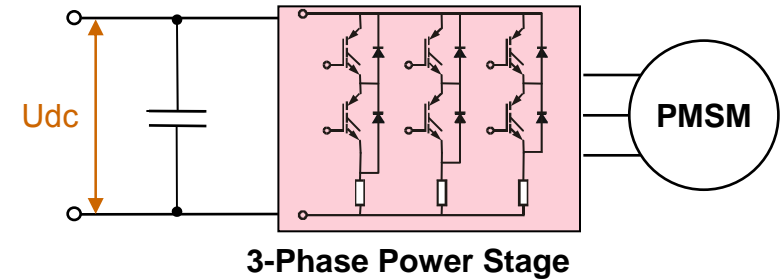

# Three Phase Voltage Generation

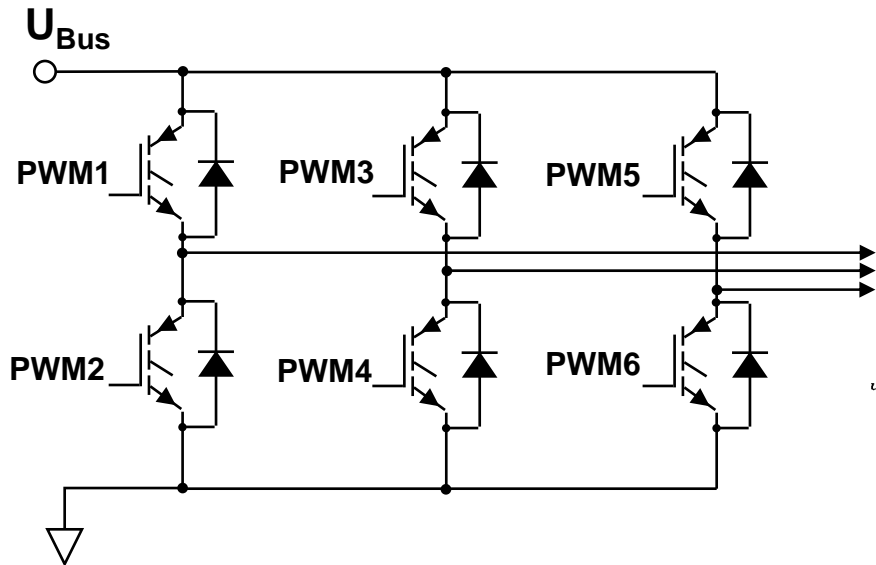

Source: Power Electronics, by Ned Mohan, Tore Undeland, and William Robbins, John Wiley & Sons, 1995

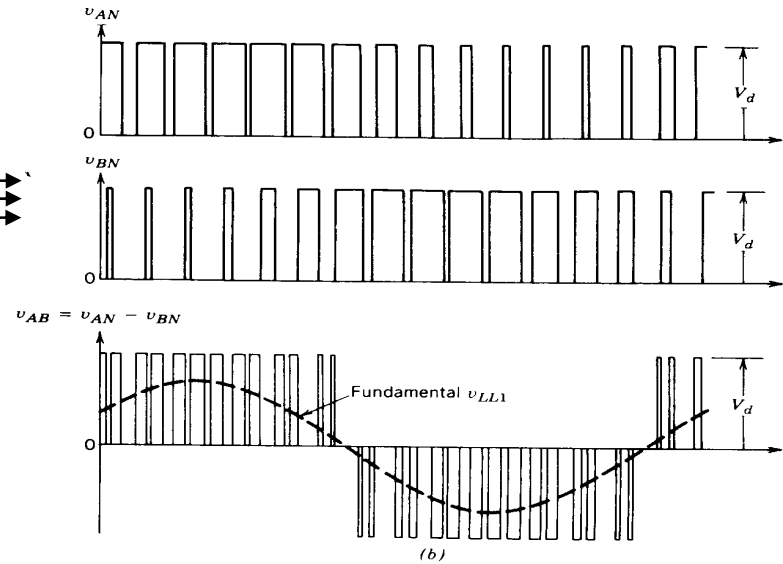
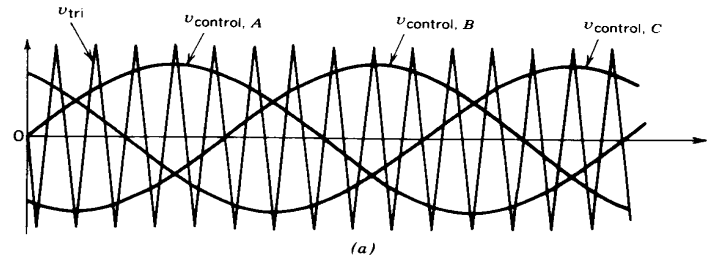

$$\frac{(\hat{V}_{LL})_h}{V_d}$$

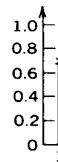

Three-phase PWM waveforms and harmonic spectrum.

$$m_a = 0.8, m_f = 15$$

Harmonics of  $f_1$

# Sinusoidal Modulation - Limited in Amplitude

- ▶ In sinusoidal modulation the amplitude is limited to half of the DC-bus voltage
- ▶ The phase to phase voltage is then lower than the DC-bus voltage (although such voltage can be generated between the terminals)

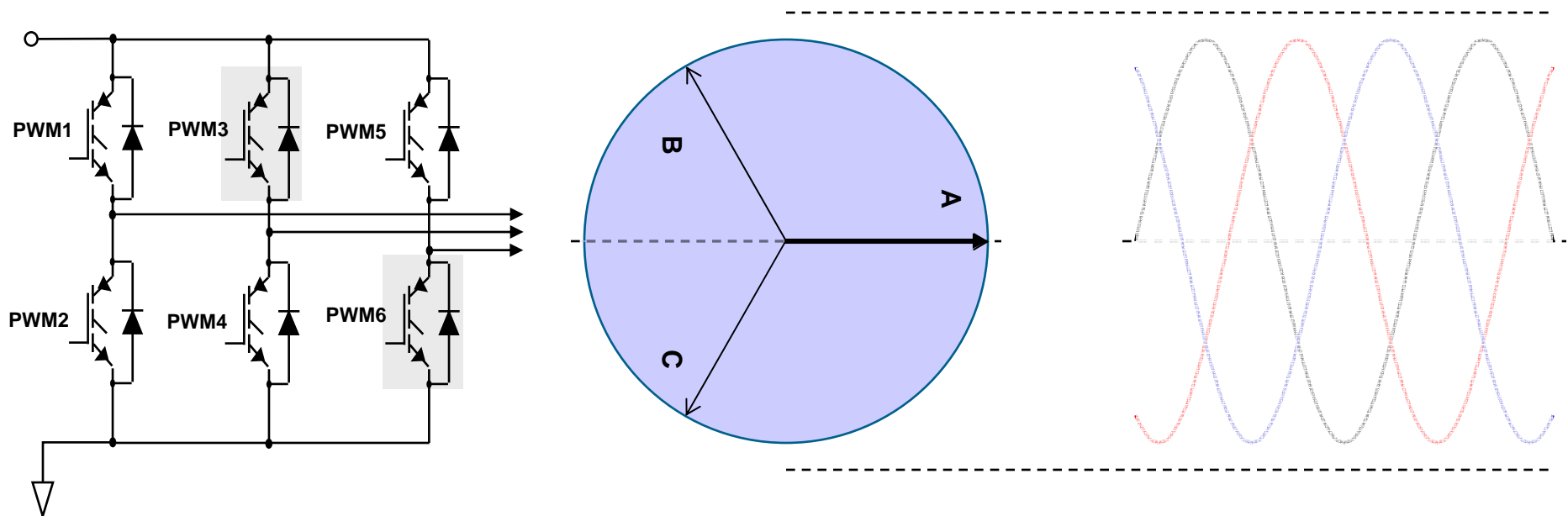

Can such a modulation technique be found that would generate full phase-to-phase voltage?

# Sinusoidal Modulation - Limited in Amplitude

- ▶ In sinusoidal modulation the amplitude is limited to half of the DC-bus voltage
- ▶ The phase to phase voltage is then lower than the DC-bus voltage (although such voltage can be generated between the terminals)

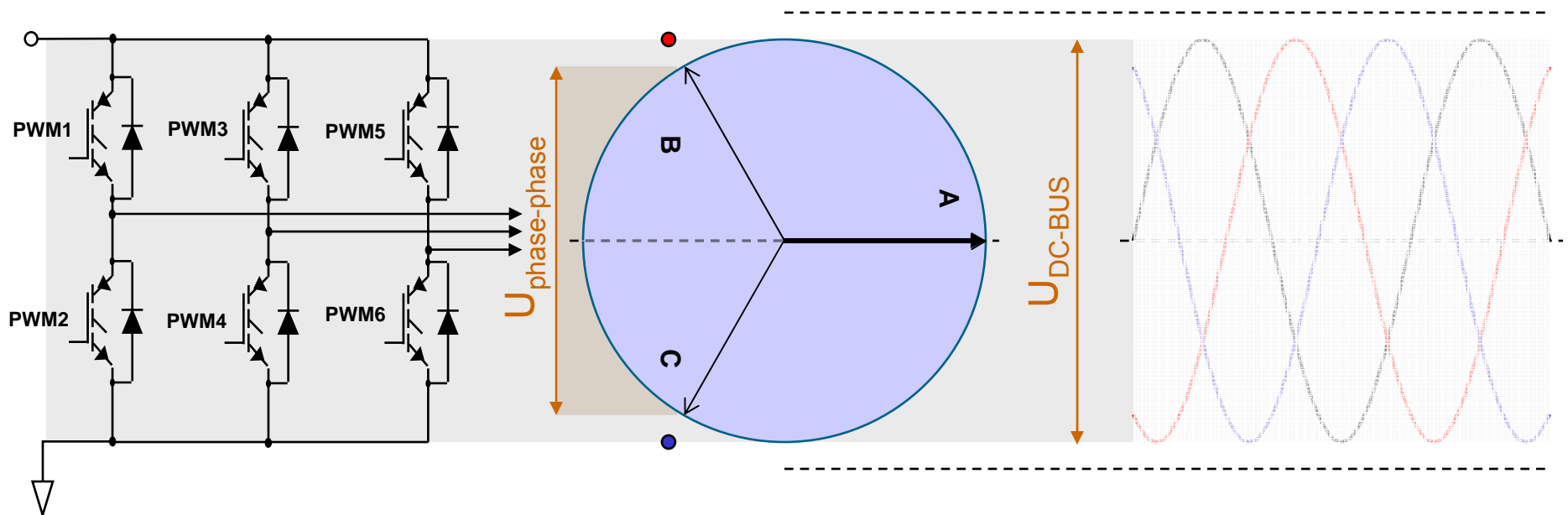

Can such a modulation technique be found that would generate full phase-to-phase voltage?

# Full Phase-to-Phase Voltage Generation

- ▶ Full phase-to-phase voltage can be generated by continuously shifting the 3-phase voltage system
- ▶ The amplitude of the first harmonic can be then increased by 15.5%

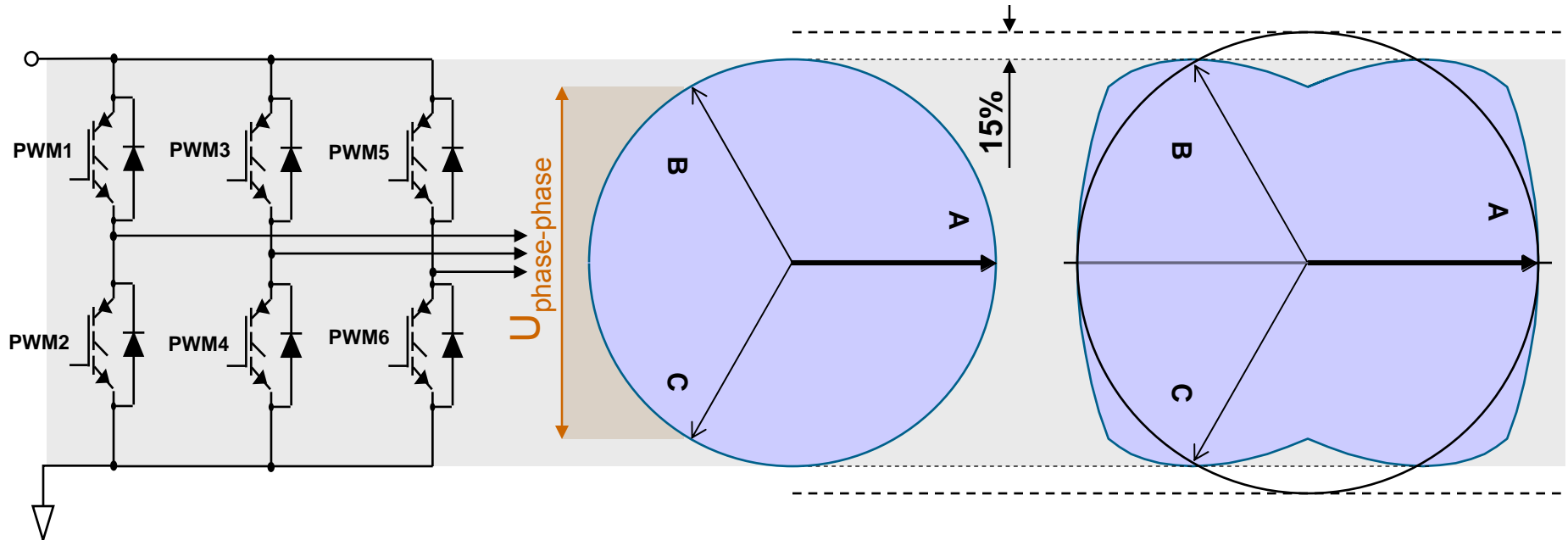

# Full Phase-to-Phase Voltage Generation

- ▶ Full phase-to-phase voltage can be generated by continuously shifting the 3-phase voltage system
- ▶ The amplitude of the first harmonic can be then increased by 15.5%

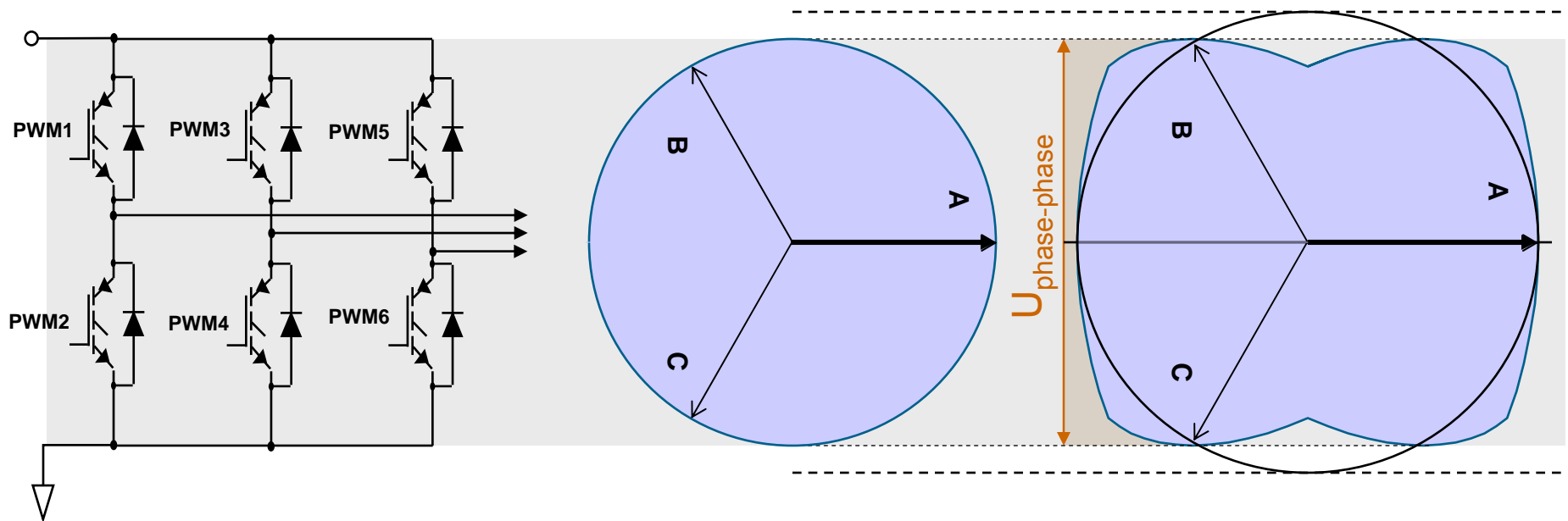

# How to Increase Modulation Index

- ▶ Modulation index is increased by adding the “shifting” voltage  $u_0$  to first harmonic
- ▶ “Shifting” voltage  $u_0$  must be the same for all three phases, thus it can only contain 3<sup>r</sup> harmonics!

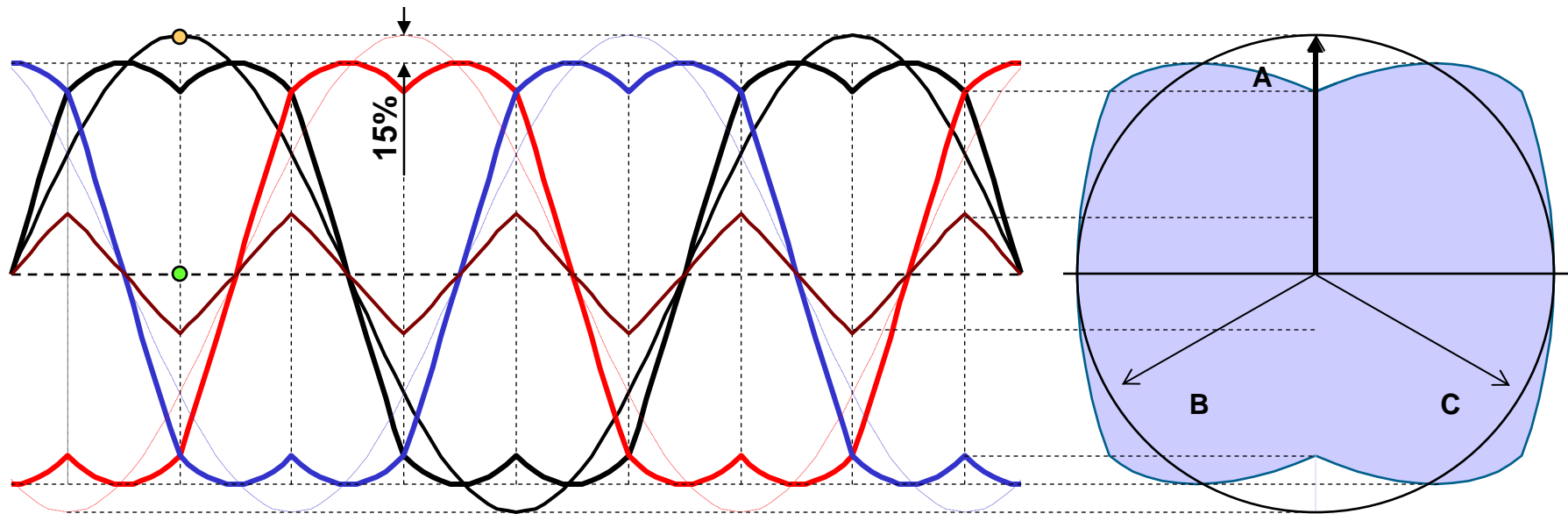

# How to Increase Modulation Index

- ▶ Modulation index is increased by adding the “shifting” voltage  $u_0$  to first harmonic
- ▶ “Shifting” voltage  $u_0$  must be the same for all three phases, thus it can only contain 3<sup>r</sup> harmonics!

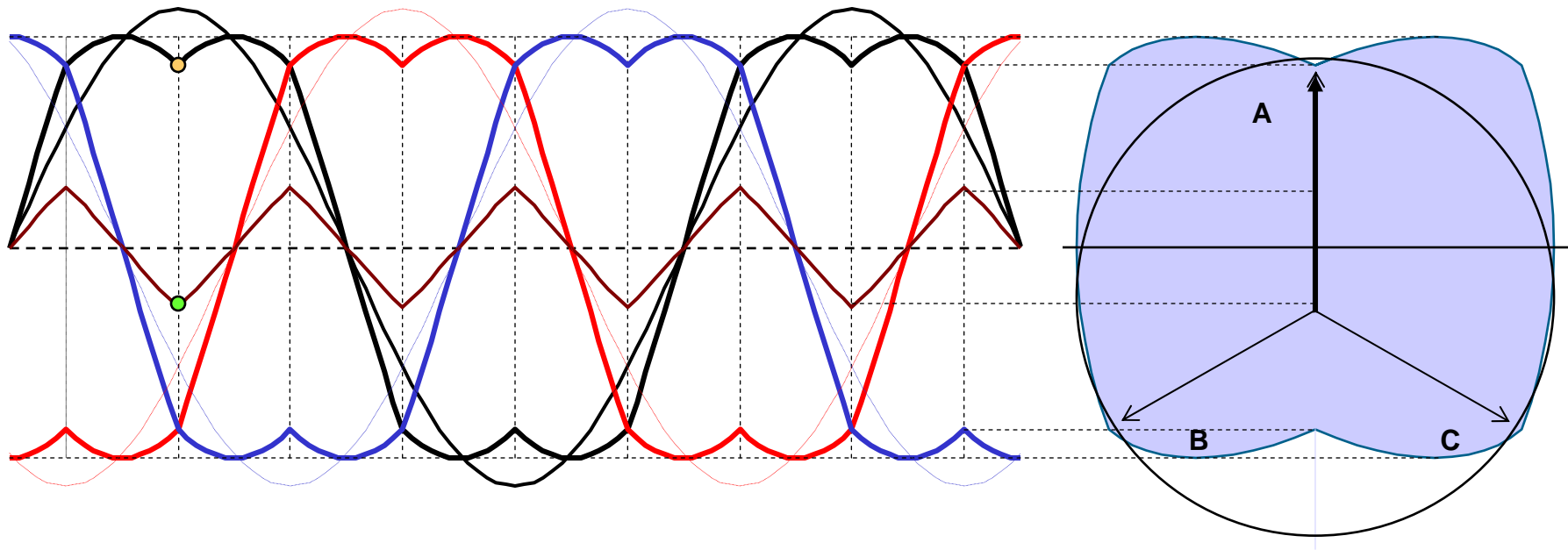

# Field Oriented Control Summary

- ▶ Using vector control technique, the control process of AC induction and PM synchronous motors is similar to control process of separately excited DC motors
- ▶ In special reference frame, the stator currents can be separated into:
  - Torque-producing component
  - Flux-producing component
- ▶ Wide variety of control options
- ▶ Better performance
  - Full motor torque capability at low speed
  - Better dynamic behavior
  - Higher efficiency for each operation point in a wide speed range
  - Decoupled control of torque and flux
  - Natural four quadrant operation

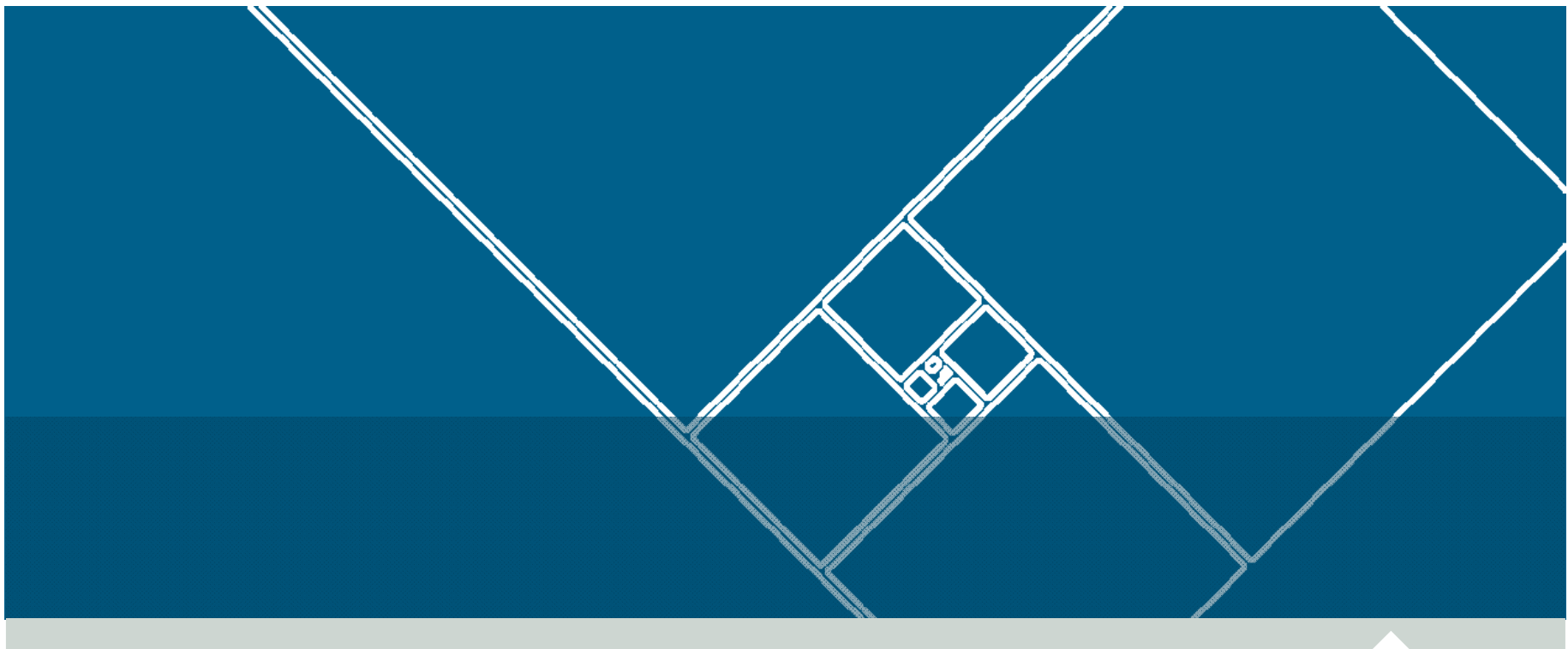

# Energy Storage System

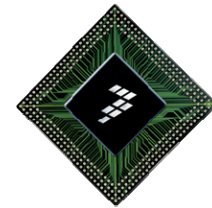

# Battery Energy Storage

## ▶ Current technology offers:

- high power density
- flat discharge and regeneration power curves
- fast charge capability
- low heat content per watt hour of stored energy
- wide state of the charge window
- low impedance growth over time



Source: EnerDel, A123

# DC/DC Converter Operation

## ▶ Operating Modes

### Voltage boosting

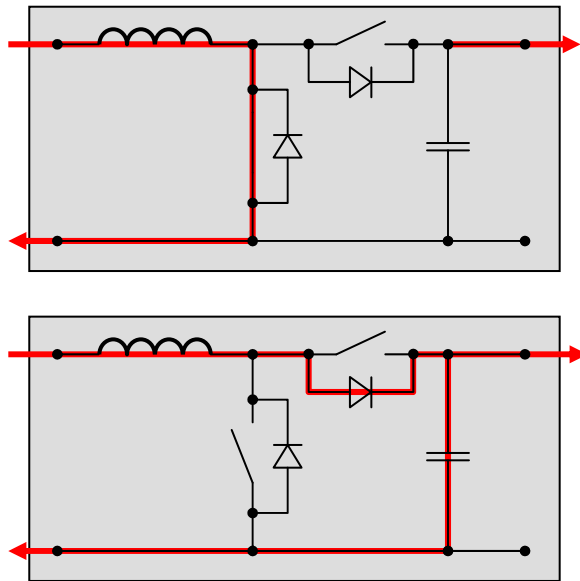

### Battery charging

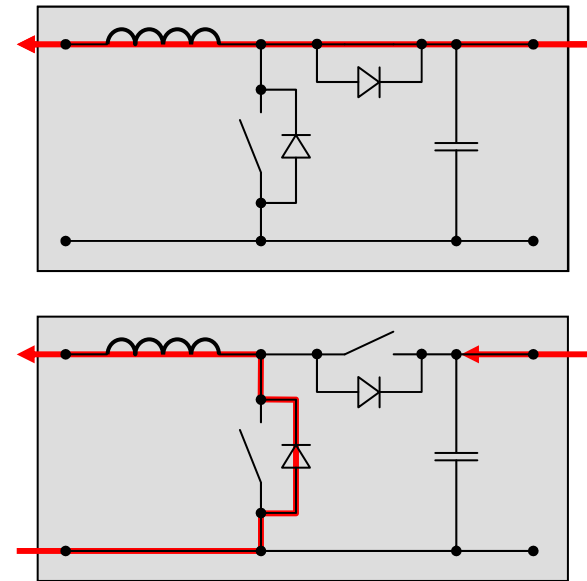

# DC/DC Converter – Advanced Design

- ▶ Converter is split into several phases:
  - Allows for lower current power devices to be used in each phase
  - Prevents difficult paralleling of the power devices
  - Enables to reduce battery current ripples by phase shifting the operation of each individual converter.

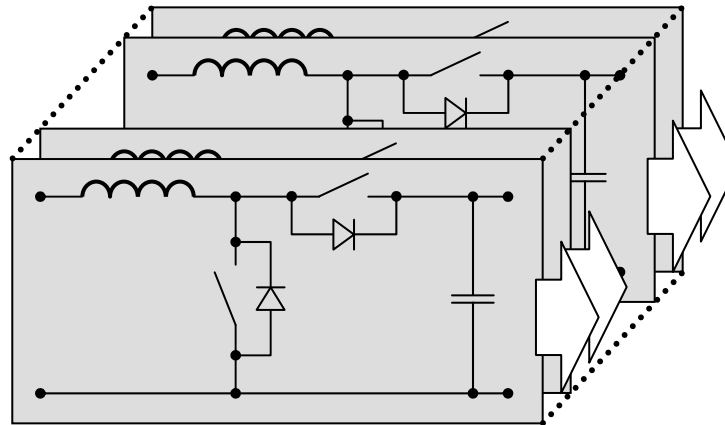

# Flywheel Energy Storage - CD DYNASTORE®

## ► Reluctance motor

- high inertia of rotor
- homogeneous rotor  
no windings, magnets,  
rotor cage
- no induced voltage during idle  
operation

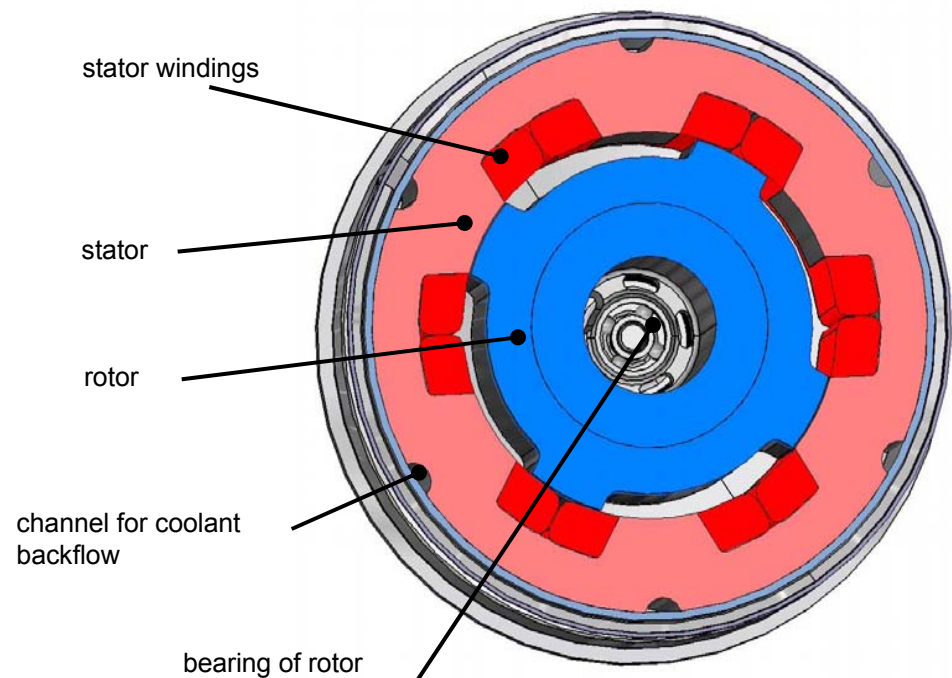

Source: Compact Dynamics

# SR Motor Control Basics

► The rotor position is needed for proper commutation of motor phases

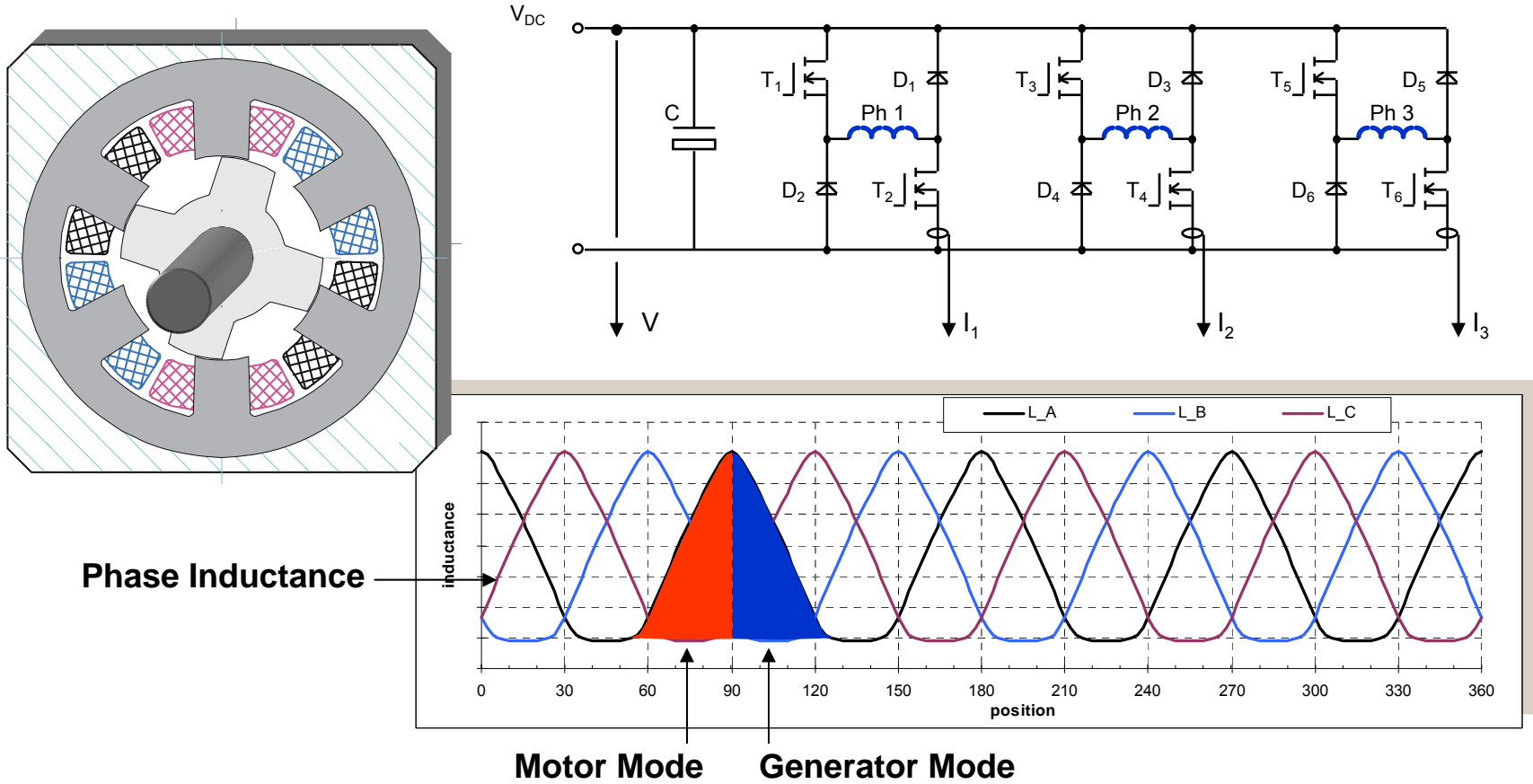

# Sensorless SR Motor Control Based on Inductance Slope Detection

- ▶ Inductance slope detection is transformed to the current peak detection

## Block Diagram

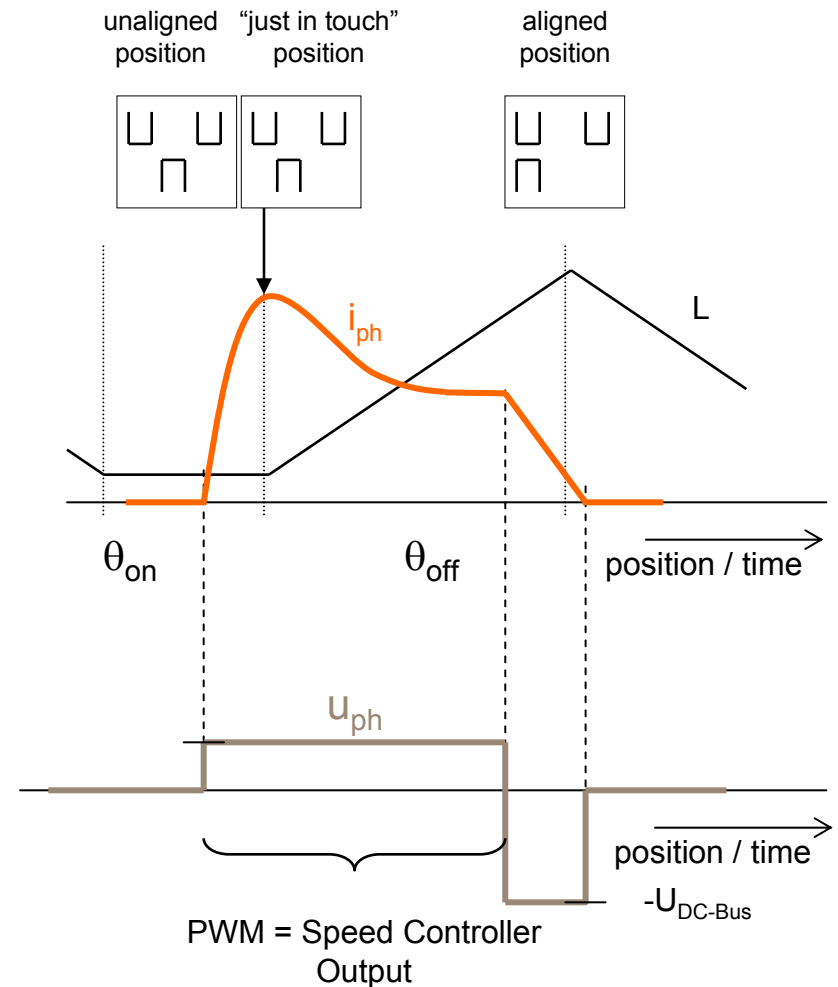
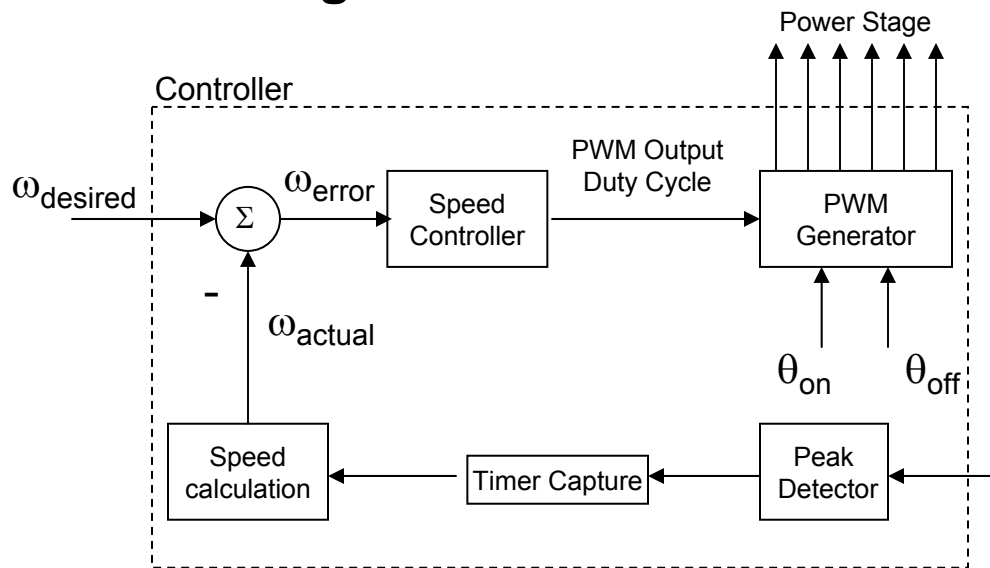

# Sensorless SR Motor Control Based on Flux Linkage Estimation

- Flux linkage is calculated in real time and compared to curve stored in memory

$$\Psi_{Est} = \int_{t1}^t (u - R^* \cdot i) dt$$

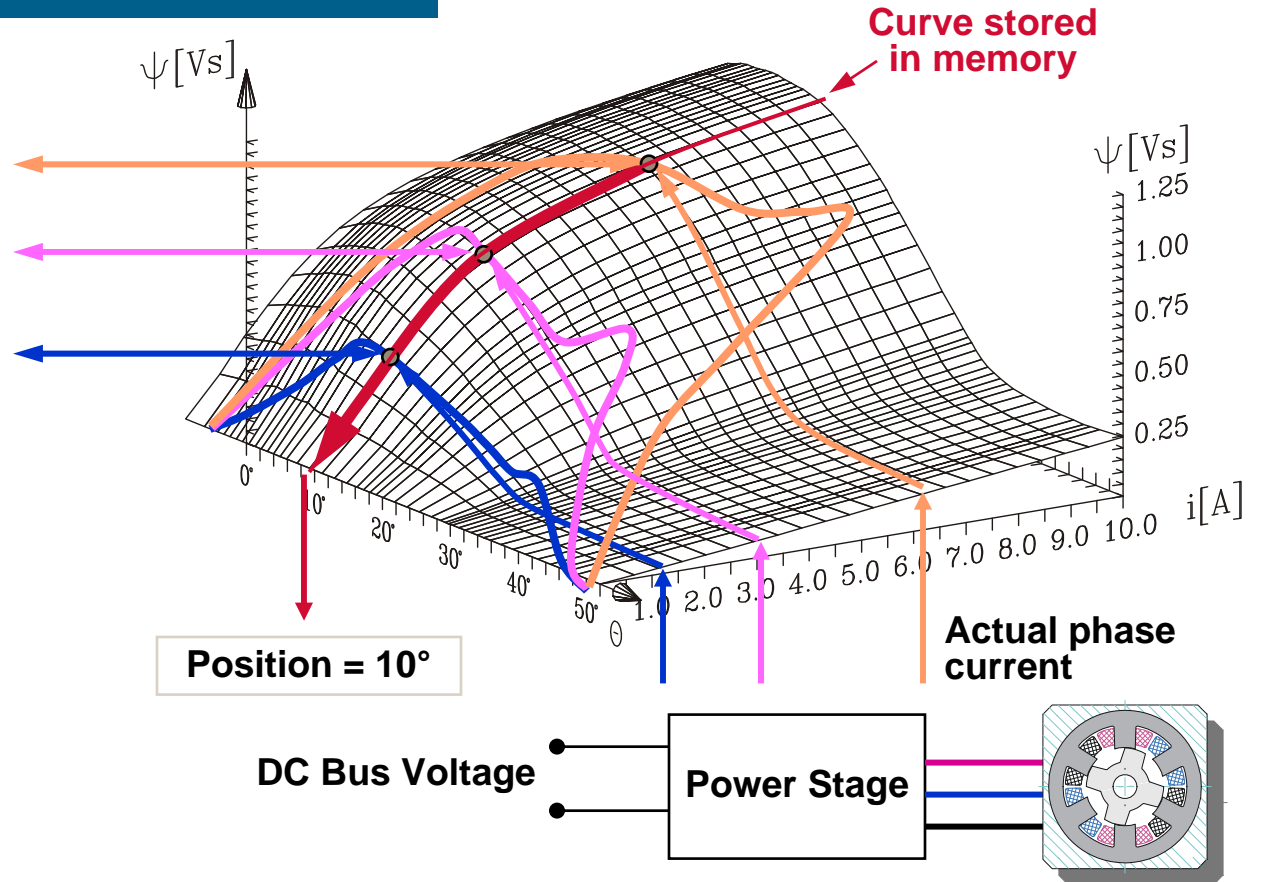

# On-Fly Phase Resistance Estimation

## Freescale Patent

$$\Psi_{Est(t2)} = \int_{t1}^{t2} (u - (R + \Delta R) \cdot i) dt$$

$\Delta R$   
 ↑  
 resistance error

$$\Psi_{Est(t2)} = \int_{t1}^{t2} (u - R \cdot i) dt - \int_{t1}^{t2} \Delta R \cdot i dt$$

$$\Psi_{Est(t2)} = \underbrace{\Psi_{(t2)}}_{\text{real magnetic flux} = 0} + \Psi_{Est\_Error(t2)}$$

$$\Psi_{Est(t2)} = - \int_{t1}^{t2} \Delta R \cdot i dt = \Psi_{Est\_Error(t2)}$$

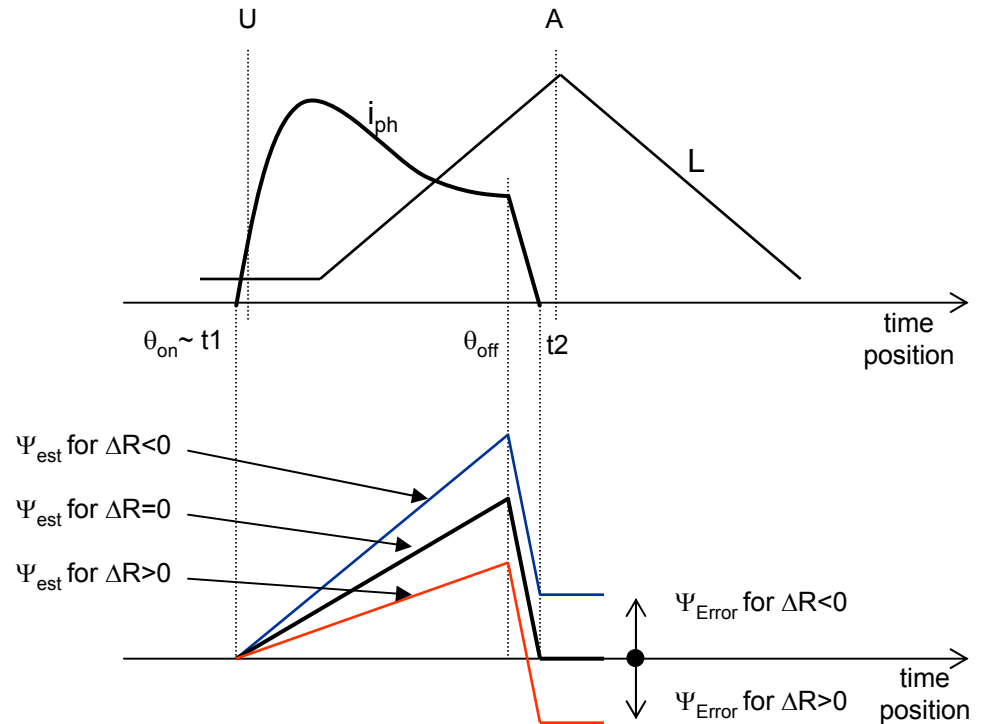

- Calculation of the flux estimation error at the time point (t2) when phase current falls to the zero level

$$\Delta R = - \frac{\Psi_{Est\_Error(t2)}}{\int_{t1}^{t2} i dt}$$

- Calculation of the resistance error for resistance slow rate of change (temperature drift)

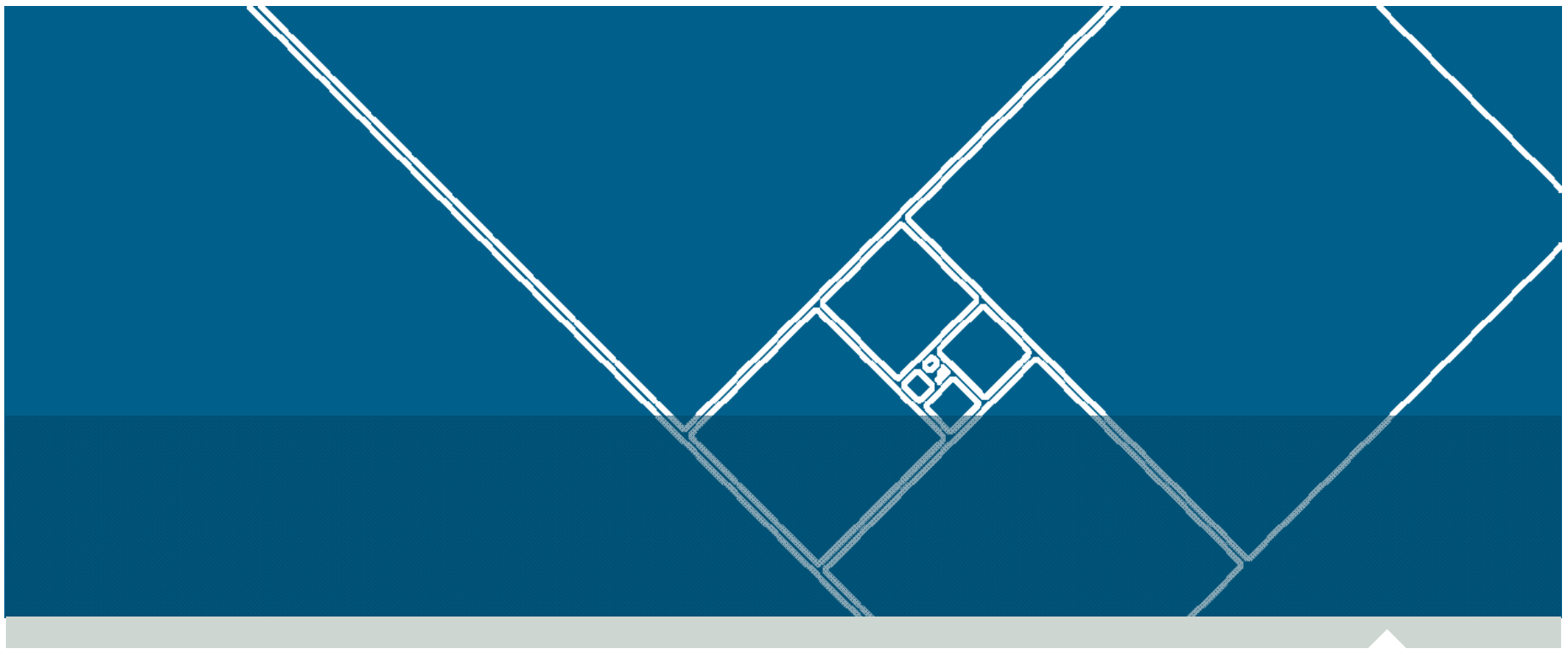

# Freescale Advanced Peripherals

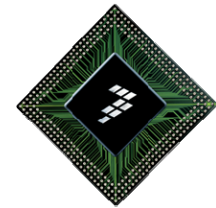

# MC Peripherals System Diagram

- ▶ Advanced peripherals (like flexPWM, fast ADC and Cross Triggering Unit) enable efficient and cost effective control of the main KERS components - eMotor, DC/DC convertor and battery pack or flywheel energy storage

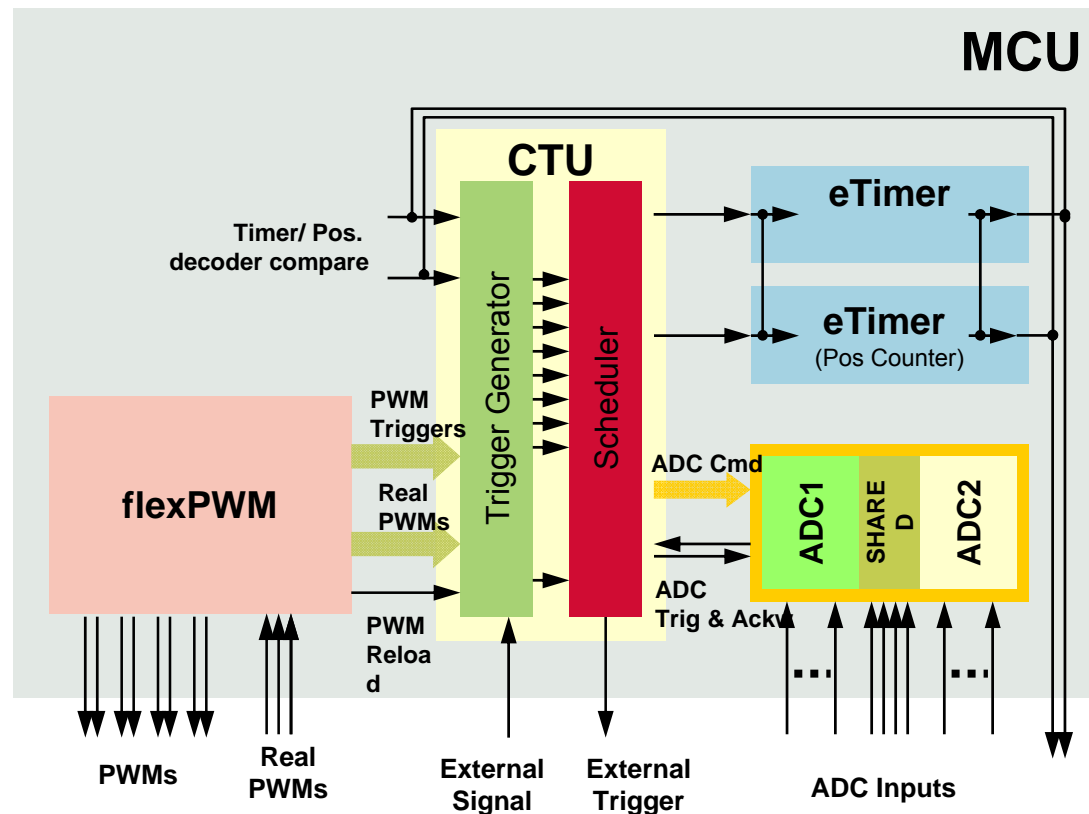

# Electric Motor Control Peripherals

## Cross Triggering Unit

- Allows mcTIM, PWM, ATD to be synchronized
- Automatic ADC & eTimer acquisitions
- No CPU intervention during the control cycle

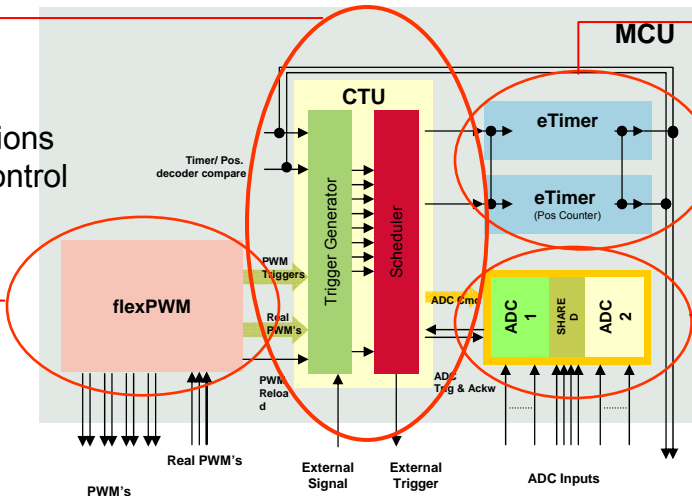

## Timer Module:

- Six Ch IC/OC
- Double buffered registers for detecting two edges in a row
- eDMA supported
- Integrated quad decoder support
- 2 x BUS frequency → high resolution

## 2x ADC

- Up to 24channels, with 4 shared.
- 10-bit
- 760 nsec conversion time
- Limit checking & zero crossing detect

## FlexPWM

- Optimized for 3ph motor control
- One „extra“ pair of PWM integrated
- Includes dead time insertion, fault channels, center/edge alignment, Distortion correction, ...
- Register protections
- Double buffered registers
- eDMA supported
- 2 x BUS frequency → **high resolution**

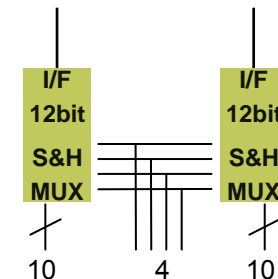
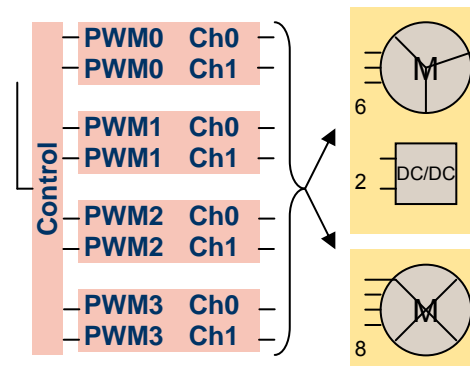

# Motor Control PWM Peripheral Module

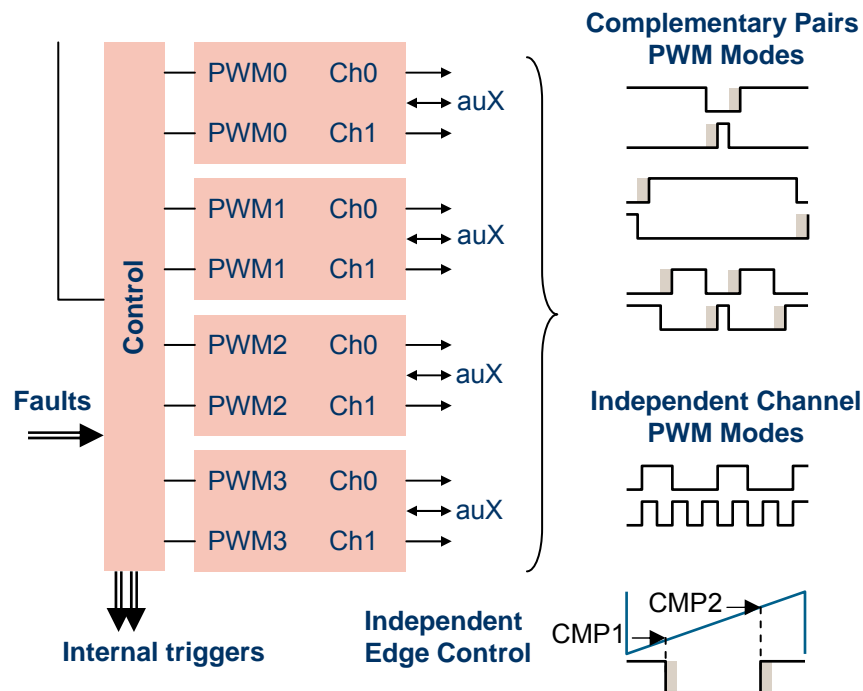

- Permanent magnet synchronous motor (PMSM, PMAC)
- Brushless DC motor (BLDC)
- Brush DC motor (BDC)
- AC induction motor (ACIM)
- Switched reluctance motor (SRM)
- Variable reluctance motor (VRM)
- Stepper motors
- DC/DC converters

## ▶ Main Features

- ▶ 4 Sub modules, each with complementary PWM generation, Isense IC/OC and fault input
- ▶ 16 bits of resolution for center, edge aligned, and asymmetrical PWMs
- ▶ PWM outputs can operate as complimentary pairs or independent channels
- ▶ Independent control of both edges of each PWM output
- ▶ Independently programmable PWM output polarity
- ▶ Separate dead time for rising and falling edges
- ▶ Each complementary pair can operate with its own PWM frequency and dead time values
- ▶ All outputs can be programmed to change simultaneously via a "Force Out" event
- ▶ Double buffered PWM registers
  - Integral reload rates from 1 to 16
  - Half cycle reload capability

## ▶ Safety

- ▶ Write protection for critical registers
- ▶ Fault inputs can be assigned to control multiple PWM outputs
- ▶ Programmable filters for fault inputs

# Use Case for Cross Triggering Unit

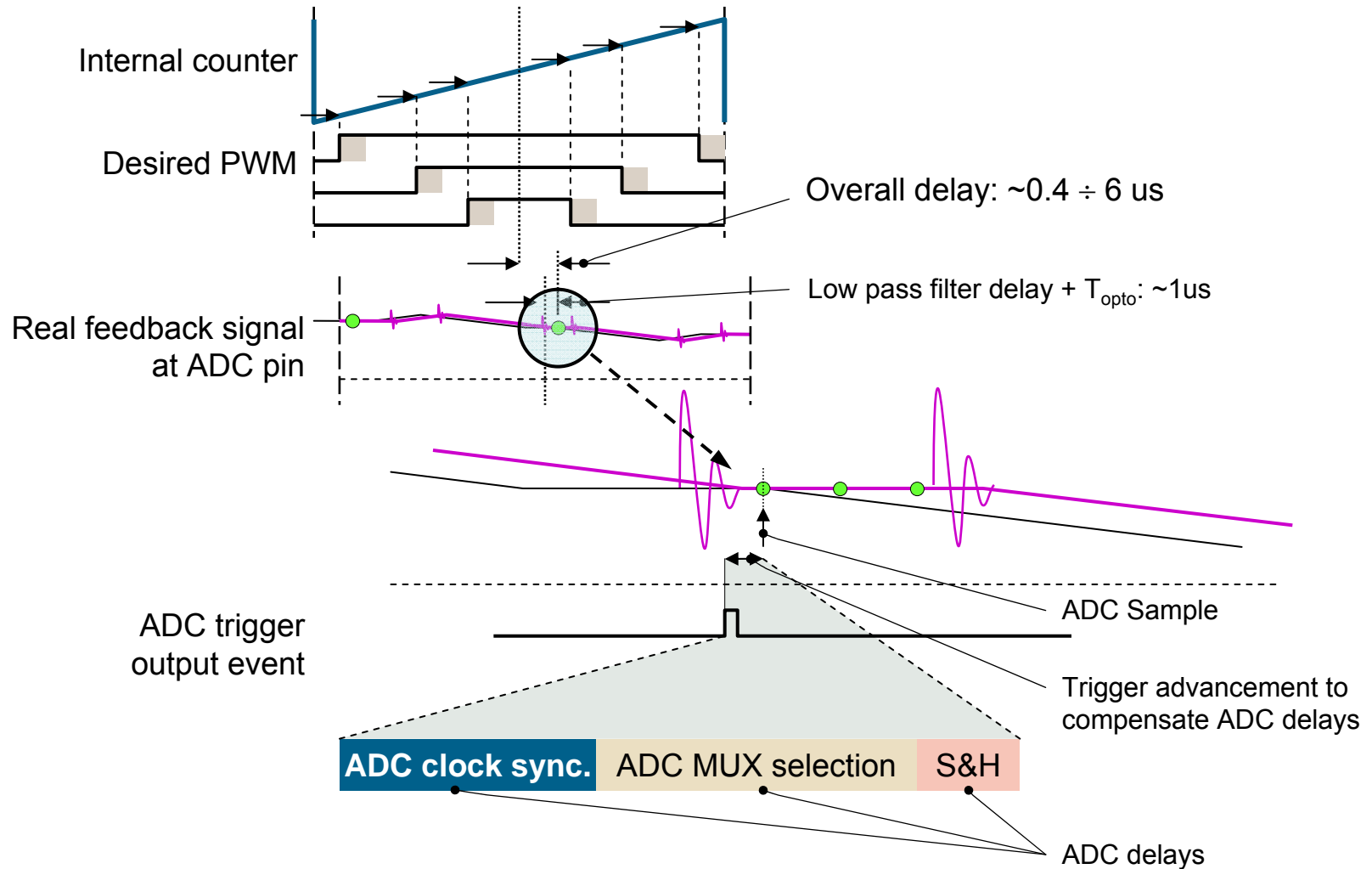

# Motor Control eTimer Peripheral Module

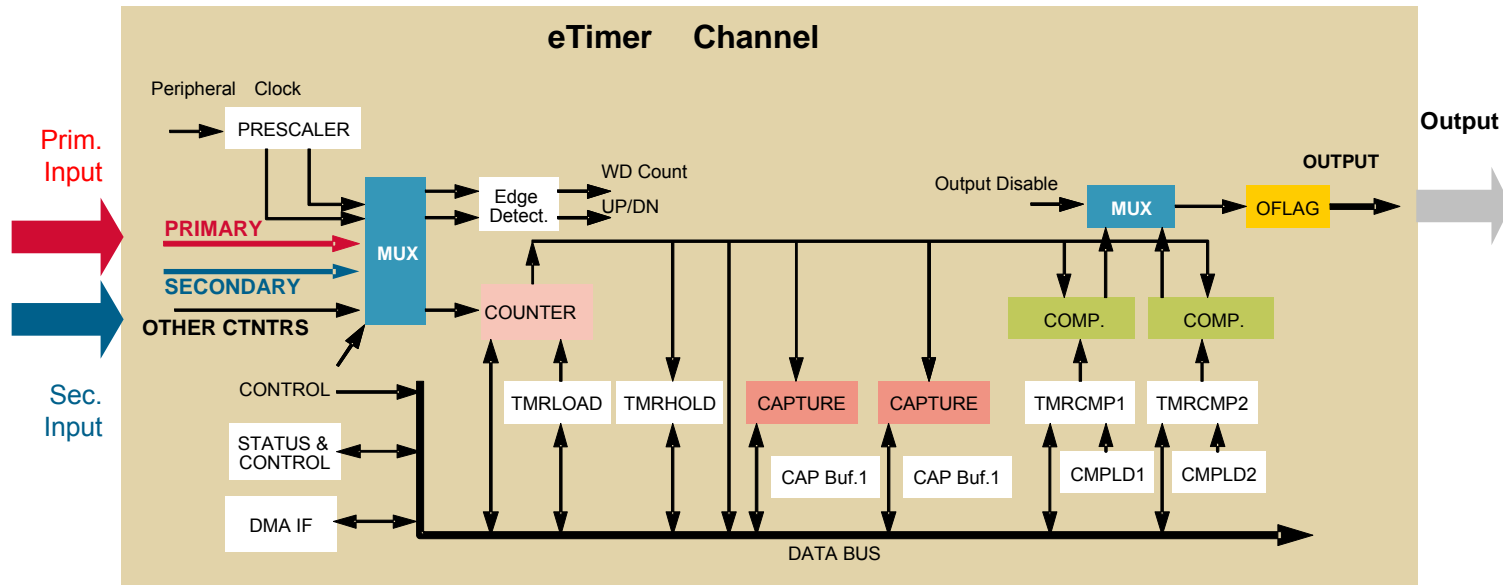

## ▶ Main Features

- ▶ Six 16-bit general purpose up/down timer/counter per module
- ▶ Powerful multiplexer between external pins and internal signals for external triggers
- ▶ Individual channel capability:
  - Input capture trigger
  - Output compare
  - Many counting modes (gating; triggered; one-shot)
  - Separate prescaler for each counter
  - Selectable clock source
  - Rotation direction flag (Quad decoder mode)
- ▶ Dual action capability per channel
  - PWM measurement 0% to 100%
- ▶ Quadrature decoder
  - rotor position
  - rotor zero speed detection (position watchdog)
- ▶ ADC trigger can also trigger input capture for rotor position measurement (ex: sin/cos sensor)
- ▶ Cascade able for higher precision (32 bits)

# eTimer — Encoder Interface Mode

- ▶ The counter is clocked by each valid transition on IC 1 or IC 2 by incremental encoder
- ▶ Depending on the sequence the counter counts, automatically, up or down
- ▶ The Output of Encoder Interface can be connected to Encoder Index to reset the counter on zero position detection
- ▶ The timer can provide information on encoded position
- ▶ To obtain dynamic information (speed, acceleration, deceleration) by measuring the periods between two encoder events using a second timer

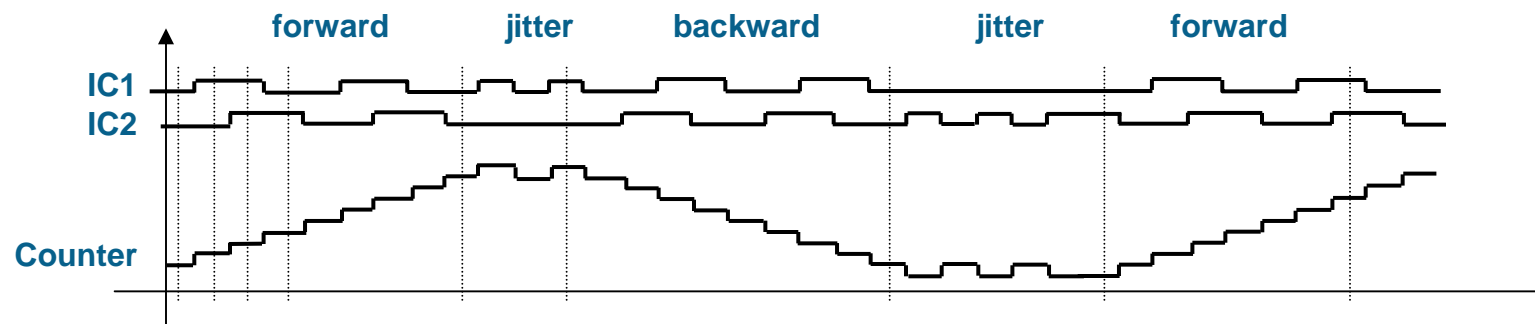
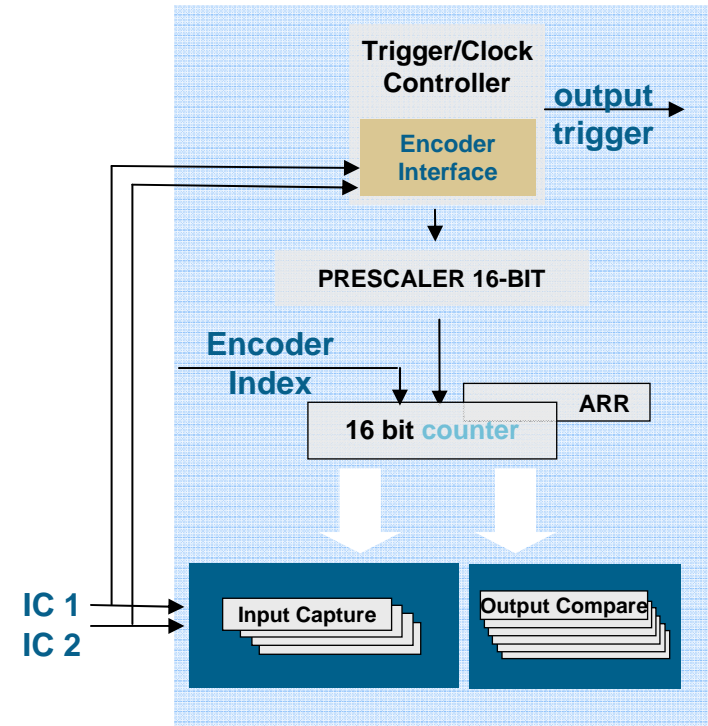

# Resolver Driver and Interface

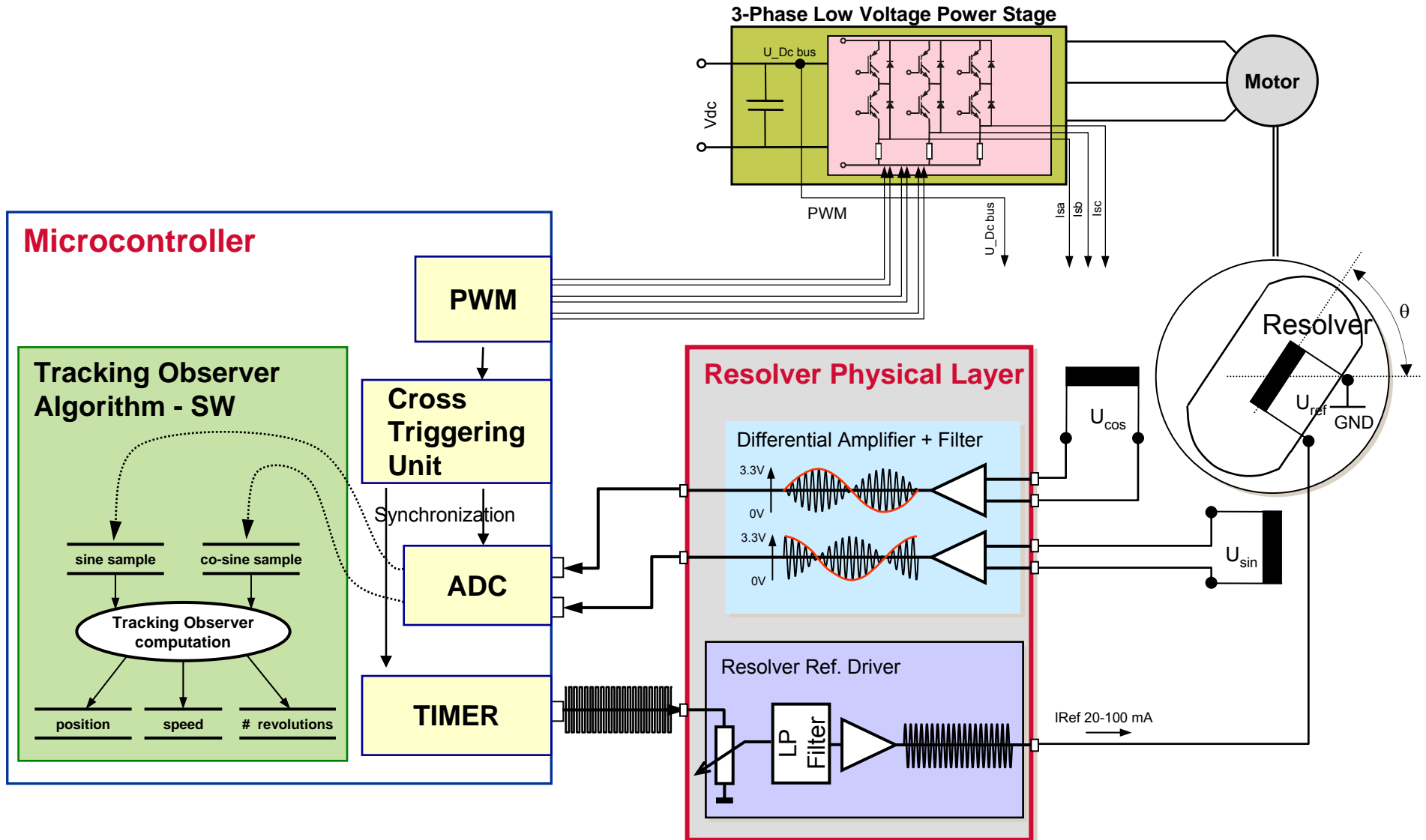

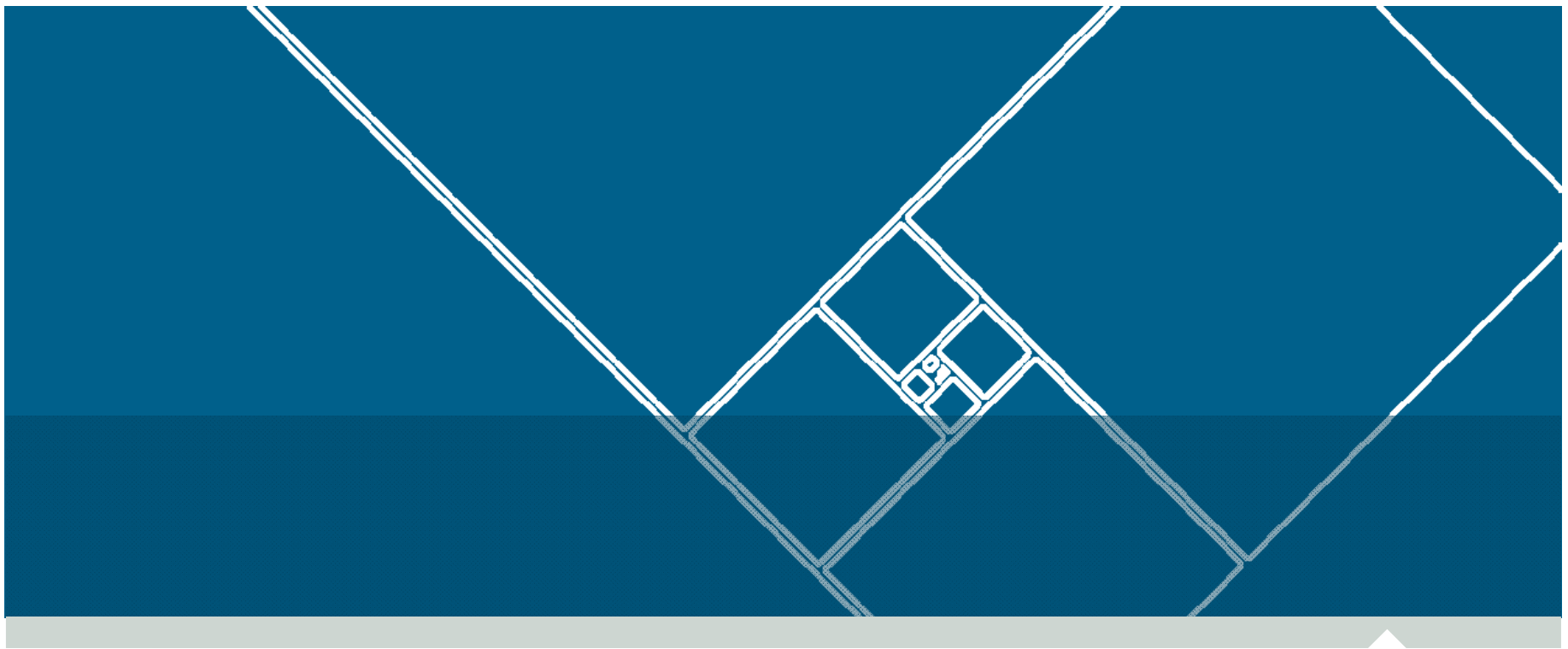

## Motor Control on Freescale Website

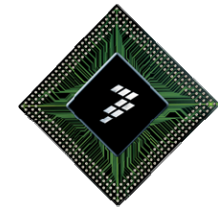

Reference designs, application notes, ...

# Freescale Motor Control Web Pages

[www.freescale.com/motorcontrol](http://www.freescale.com/motorcontrol)



[Contact Us](#) | [Worldwide: United States](#) | [中国](#) | [日本語](#) | [한국어](#) | [购物车](#) | [Login](#) | [My Freescale](#)

Enter Part Number  [»](#)

[Products](#) | [Applications](#) | [Technologies](#) | [Support](#) | [Buy](#) | [About Freescale](#)

Enter Keyword  [»](#)

- Motor Control
- Types of Motors ▶
- Electromagnetic Actuator Control Using DSP
- Embedded Solutions
- Energy Efficient Solutions
- Home Appliances ▶
- Magnetic Card Strip Encoders and Readers with DSP
- Motion Control
- Motor Control with Wireless Sensors
- Robot Manipulator
- Robotic Arm
- Reference Designs
- FAQs

Freescale ▶ Motor Control

## Motor Control

[Subscribe](#)

Electric motors are all around us, from common appliances to our most sophisticated computers. In fact, the technology has been present for more than 100 years, with many of the earliest motor types still in broad use. Motors provide motion. Whether rotating or linear, motors enable us to move people and machines. They impact every aspect of our daily lives.

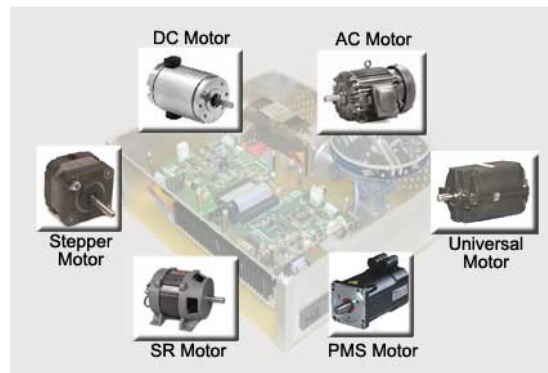

### Featured Tools

[\\$0 downloadable source code drives 3-phase AC induction motors](#)



### Featured Documents

[Motor Control Demo Video](#)  
[Motor Control Brochure](#)

### Design Resources

#### Getting Started

- [Motor Control Overview](#)
- [The Electric Motor: Here and Now](#)
- [Efficiency: The Green Story](#)
- [Strategies: Choosing MCU or DSP](#)
- [The Future: Through the Looking Glass](#)

[Motor Control Roadmaps](#)  
[Product terminology](#)

#### Support

- [Request help](#)
- [Discussion forums](#)
  - [Microcontrollers](#)
  - [Digital Signal Controllers](#)
- [Events](#)

#### Design

[Reference designs](#)  
[Motor Control Tutorial](#)  
[Design alliance program](#)

#### Buy / Sample

[Order free samples](#)  
[Buy direct \(silicon and development tools\)](#)  
[Buy from distributor](#)

#### Freescale WorldWide

[China](#)

- ▶ Thank you for attending this presentation. We'll now take a few moments for the audience's questions and then we'll begin the question and answer session.

