



Agilent Technologies

Design Techniques for First Pass RF Board Design

January 10, 2008

presented by:

Lance Lascari
RFdude.com LLC

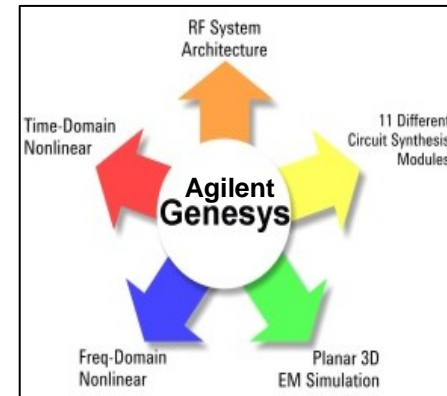

Agilent Technologies

© Copyright 2007 Agilent Technologies, Inc.

Overview

- Present a discussion on RF board design challenges, efficient implementation techniques, and simulation methods using Agilent Genesys and Momentum GX
- For specific design circuits, go over:
 - Key design choices and techniques for implementation
 - Electrical models for components and materials
 - Prototyping techniques and review the differences between measured and modeled circuit performance
 - Next steps
- Design examples:
 - Small signal amplifiers
 - Microstrip filters
 - Basic patch antennas

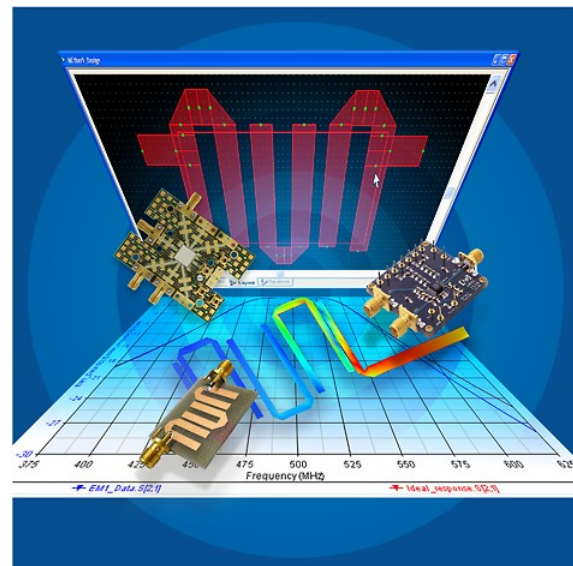

RF Board Design Issues & Realities

RF Board circuit designers are vulnerable to many sources of uncertainty:

- Passive Material parameters: uncertain baseline, poorly defined variation
 - The most popular board materials for electronics such as FR4 often show high variation in dielectric constant (ϵ_r or D_k), Loss Tangent (TAND or D_f), and even thickness across a sample.
 - L's and C's: “commodity” components can vary significantly unless a premium is paid for “RF” quality parts from selected vendors
- Active components:
 - Nonlinear models not always available
 - Very few vendors will provide statistical data on discrete semiconductors
- Physical environment:
 - The enclosure and other blocks may interact with your circuit

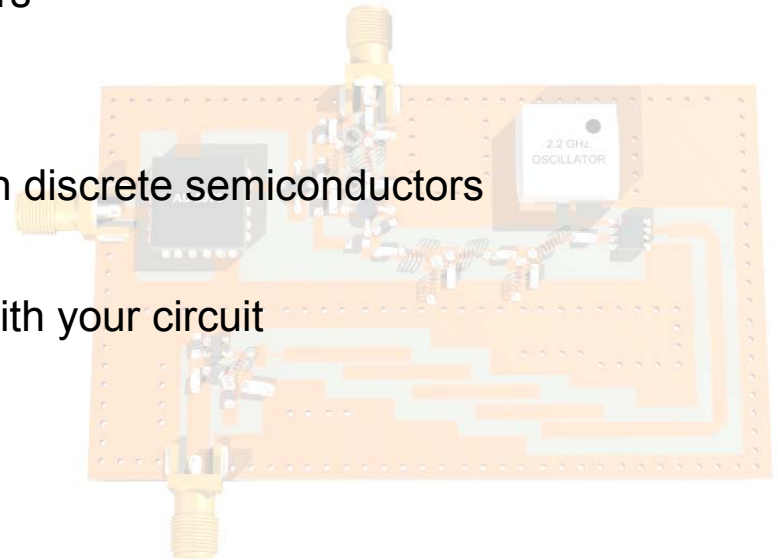

RF Board Design Philosophy & Strategies

What does the RF Board Designer do?

- Get the models that you can, most will probably be perfectly adequate
- Spend some time measuring your prototypes or final designs to be able to identify and understand discrepancies. Experience has shown the following root causes for some discrepancies:
 - Enclosure effects not considered (external feedback or even radiation)
 - Layout implementation not the same as the simulated circuit
 - Inaccurate or incomplete nonlinear models
 - Incomplete models for supporting bias circuitry
 - Ideal rather than “RF” component models used for lumped elements
 - Simple R-L-C models for inductors and capacitors not always adequate
- Keep good mental or written notes on what you can use for the next design

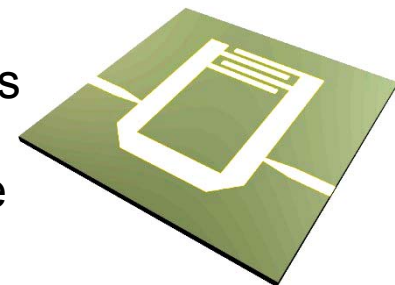
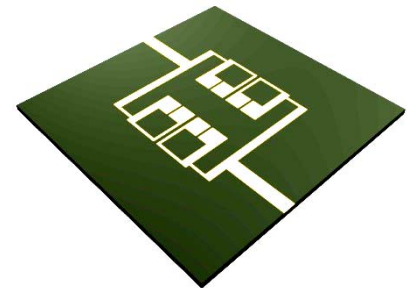
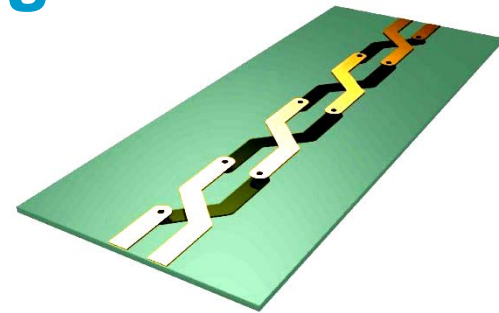

RF Board Design

Detail Level Tips for Agility & Reuse

Most RF Board circuit designs use some of the same elements over and over again.

- Parameterize as much of your design using variables as you can. Coupling/bypass caps and line widths are great examples
 - Starting with this approach makes it that much faster to move a design from one frequency to another, one substrate to another, etc.
 - Parameterization works for simulation setups too: frequency ranges for instance

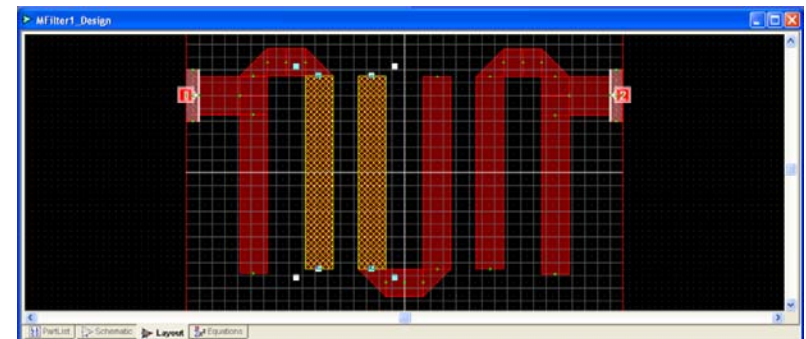
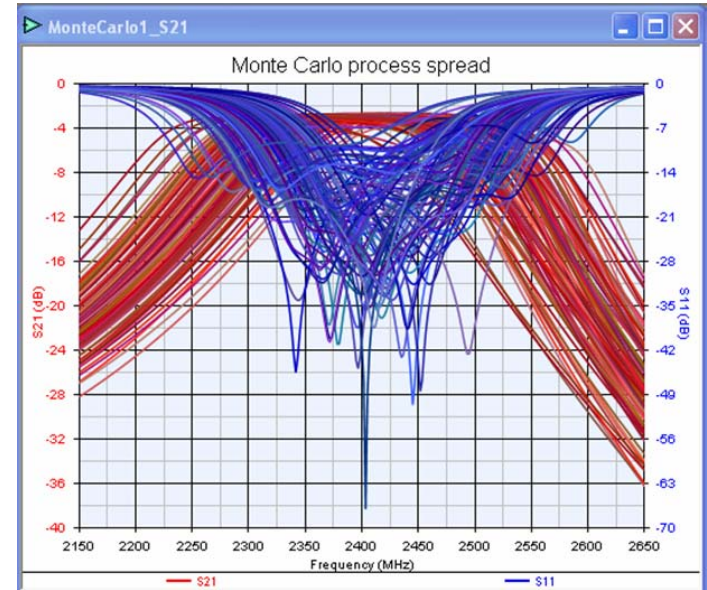

Amplifiers

General thoughts on small signal amplifiers beyond the basic gain and noise figure specs

- Stability should be considered every step of the way
 - If the circuit you're designing can be exposed to wildly varying impedances such as bandpass filters or antennas, take extra care in ensuring unconditional stability over all frequencies and verify that you have achieved this in the final hardware
- Linearity
 - Analysis and approximations can save a lot of time in the device evaluation phase

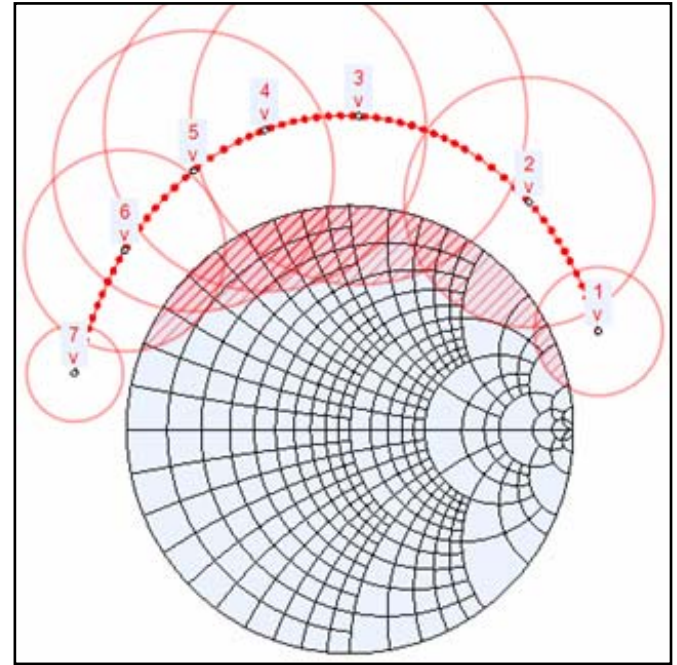

Wideband Low Noise Amplifier Example

“MMIC Replacement Amp” Specs & Challenges

Goal: develop a wideband preamplifier for VHF-UHF RX

- **Specs**

- Low noise figure: <1dB
- IIP3: >0 dBm
- $17 \text{ dB} \leq \text{Gain} \leq 25 \text{ dB}$
- Reasonable input/output return loss: >10 dB
- Frequency range: 150-450 MHz (minimum)
- Power requirements to be comparable to a typical MMIC amplifier stage

Anticipated challenges:

- Achieving this level of gain and this low noise figure calls for a very high frequency transistor, which may be very difficult to stabilize.
- High gain microwave FETs tend to have very high input impedances to achieve low noise figures, so achieving the return loss may be equally difficult

Wideband Low Noise Amplifier Example

Design Challenges, Choices & Steps

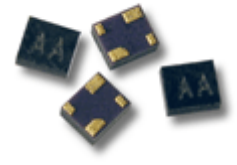

- Select transistor: **Avago Technologies ATF54143 chosen.** Very low noise and high gain, with very respectable IP3.
- Investigate methods of stabilizing ($K > 1$), and managing gain through simulation
 - Try negative feedback:
 - Simple R-C network allowed for reasonably flat gain and very good low frequency stability
 - Source inductance (microstrip lines) varied to optimize matching and stability
 - Series resistance in the drain portion of the circuit helped high frequency stability, probably required due to phase shift in R-C feedback path
- “Optimal” feedback levels provided very good wideband impedance match without using any real L-C matching sections.
- Surprisingly, the Noise Figure remained excellent!

Curtice2a Model Used for Avago ATF-54143

This is the model from the data sheet implemented in a Genesys model (put my own library).

- Consulted Agilent support to find appropriate model for this enhancement mode PHEMT.

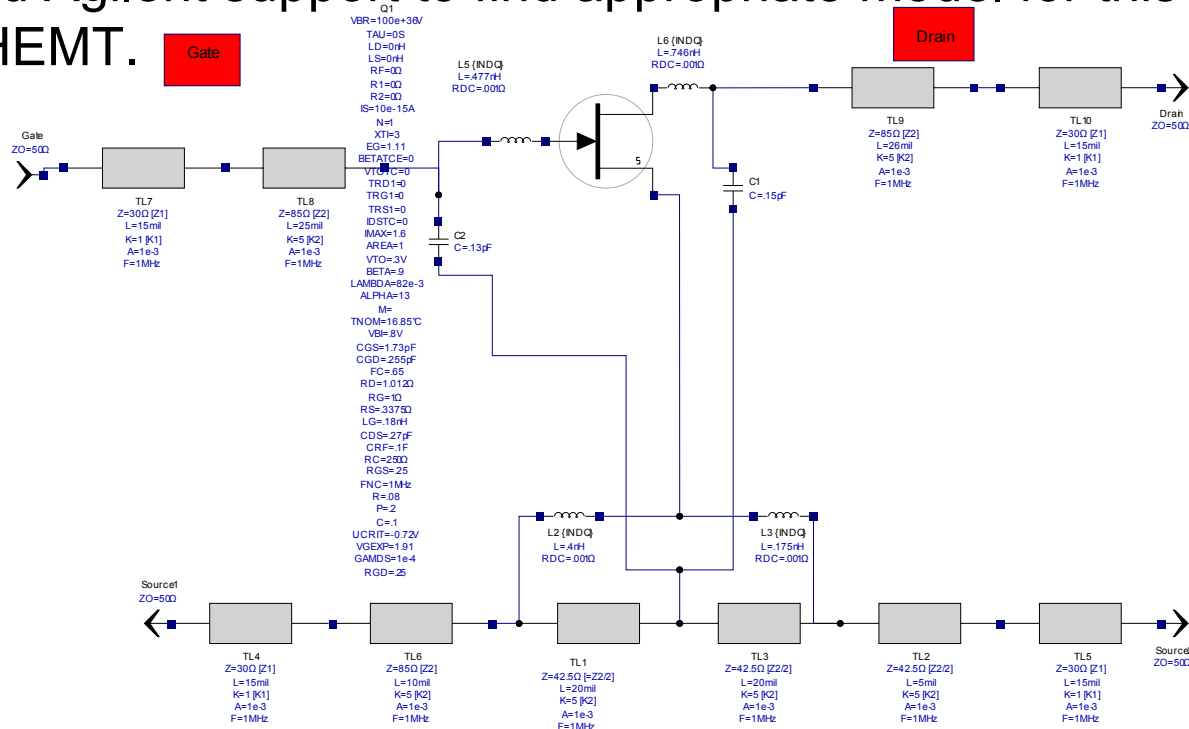

Test Circuit in Agilent Genesys for Measuring S-parameters

This type of circuit is all you need to simulate the S-parameters of a nonlinear model for comparison

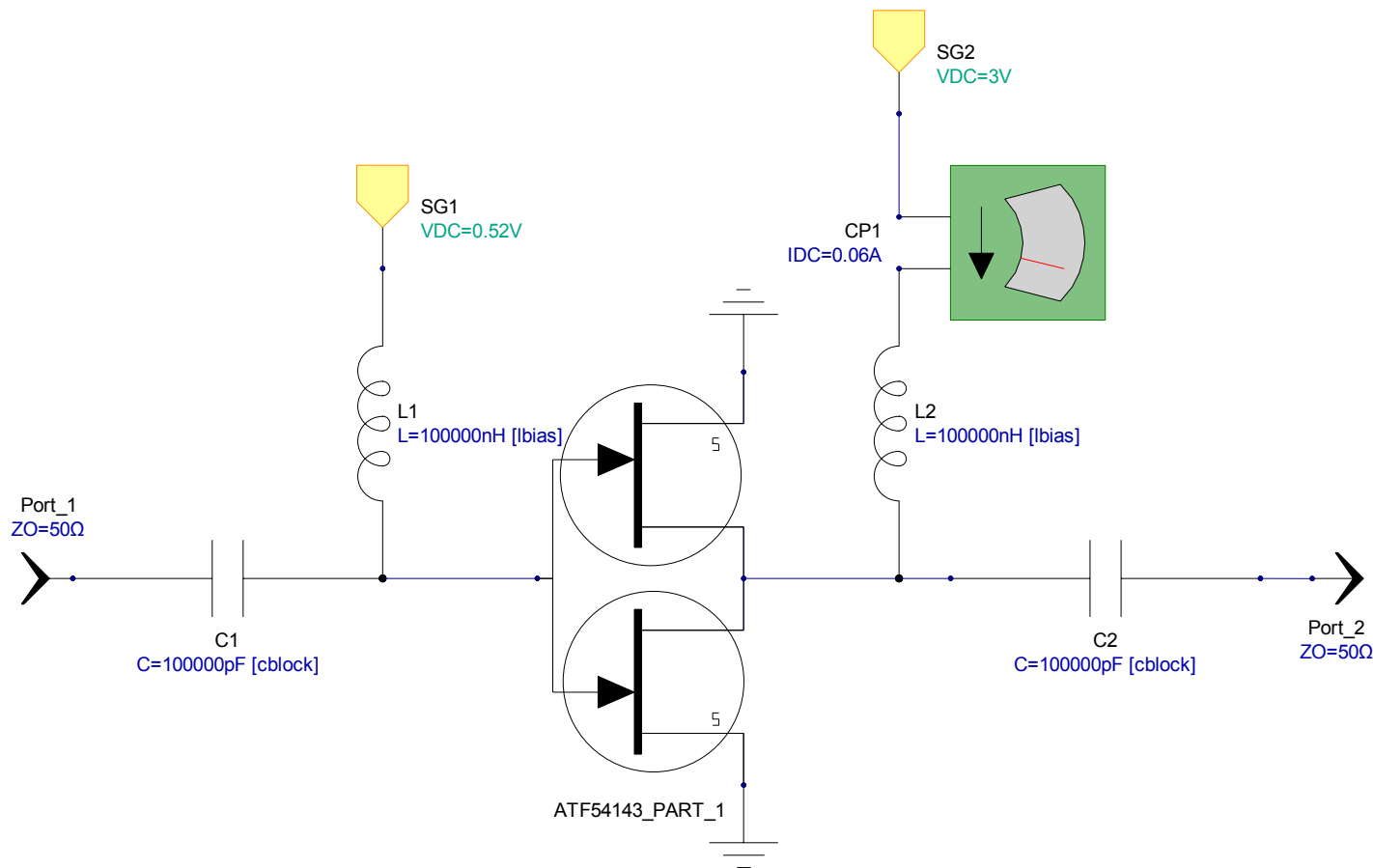

Quick Model Checks

Non-linear model comparison to the vendor S-parameters provided for this part at the same bias point

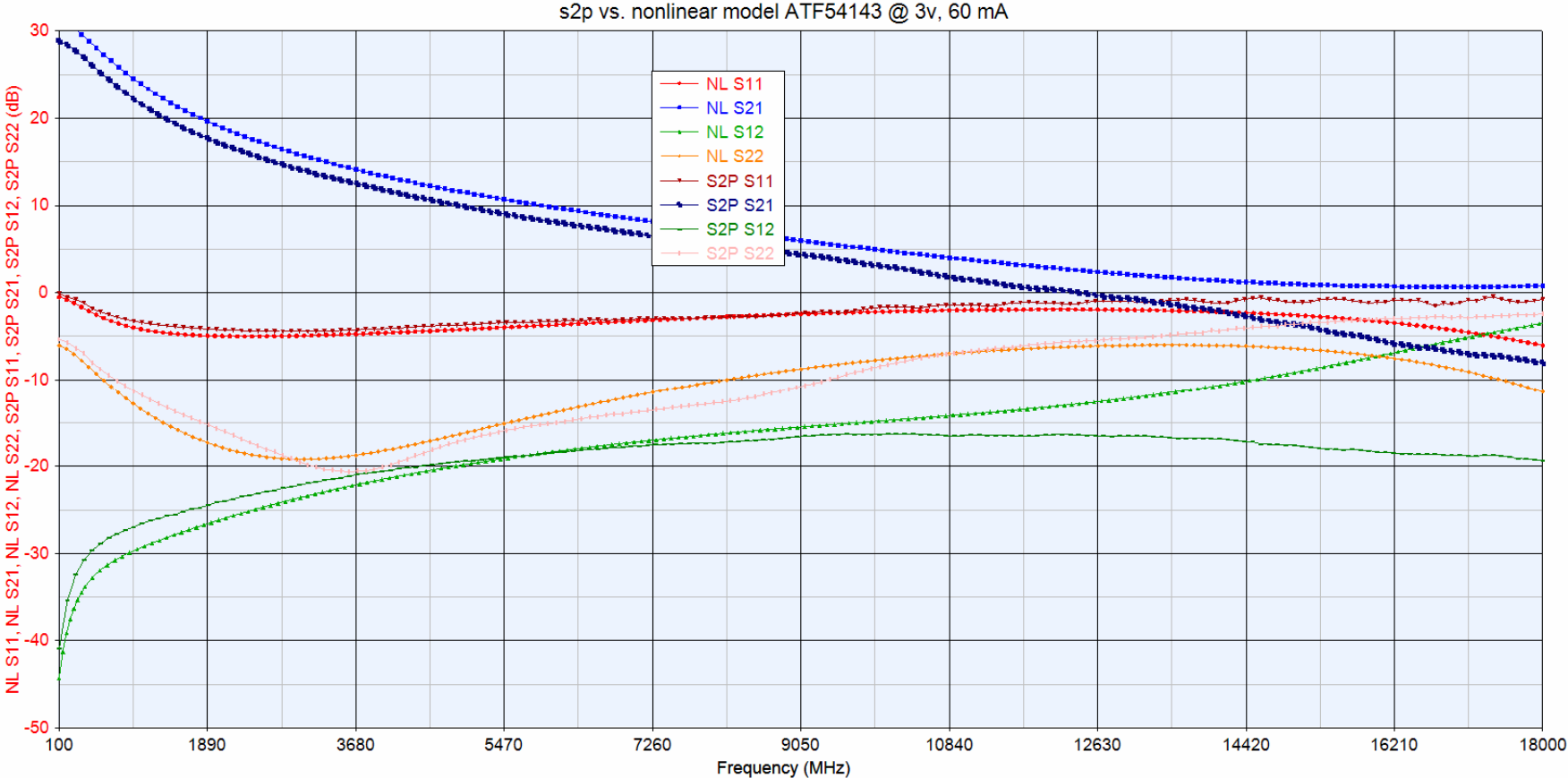

Core Amplifier in Realizable Form for Simulation

A basic amplifier with series and shunt feedback:

- Feedback resistor split in two and placed near the signal path to remove "stub" like behavior far out of band – key for stability in some circuits.
- No ideal parts used in initial design, went straight to "RF" models

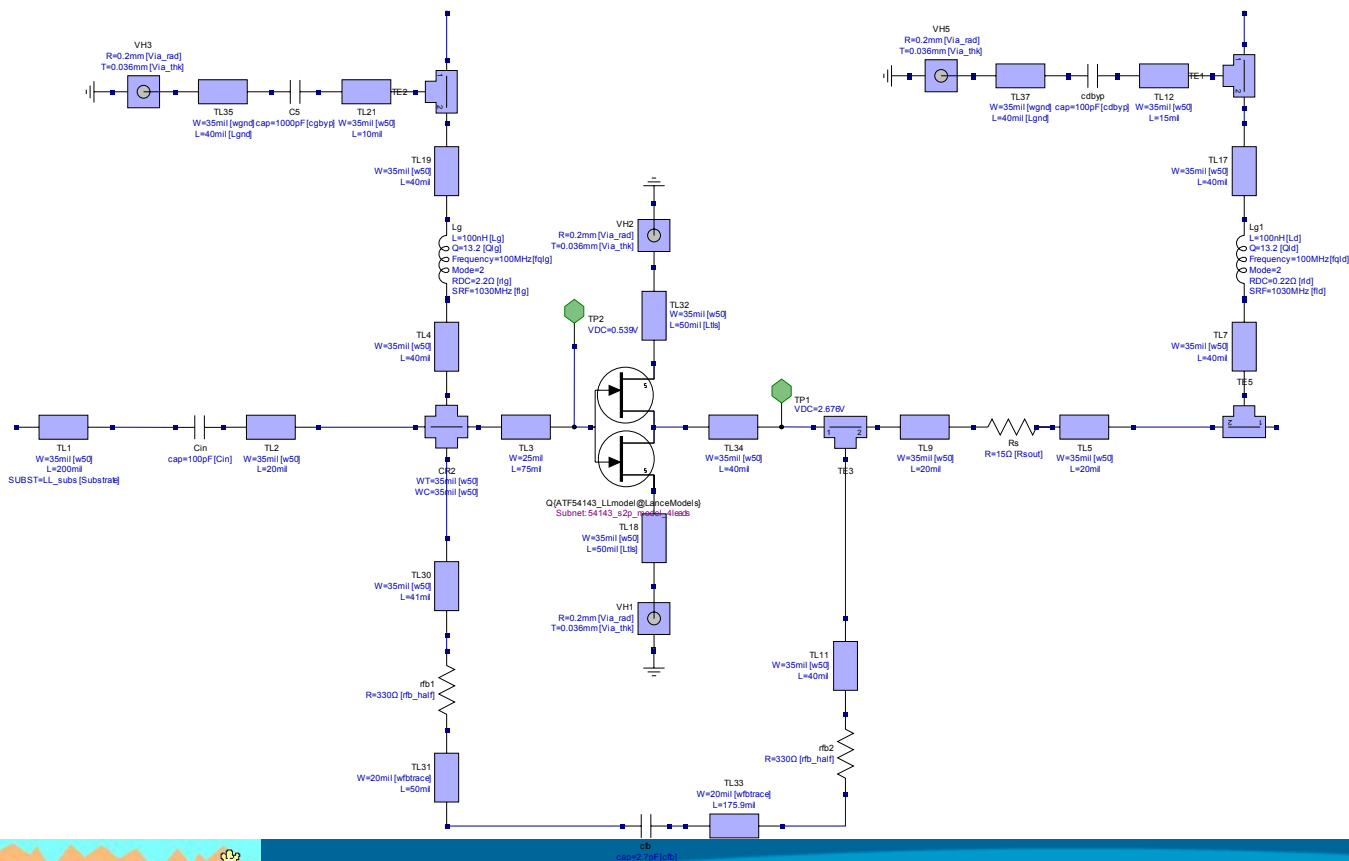

Passive Component Models

- I start with simple models that are good enough for many designs. Could go with high end model libraries for extreme cases or to minimize risk (i.e. Modelithics)
 - Resistors
 - Series R-L, with small capacitance across terminals based on size
 - Capacitors
 - Series R-L-C. R, L fixed and based on measurements per part size
 - Inductors
 - INDQ model used with additional capacitor across it. Custom model with “SRF” parameter used to calculate capacitance for vendor provided minimum self resonant frequency.
 - **Tip: Make sure you have appropriate footprint models with footprint ports for accurate EM simulation (examples in Genesys are a good starting point)**

Amplifier Design: Schematic, Layout & Prototype

Great detail in schematic to produce a more accurate model and create the layout automatically. No unexpected changes between versions with defined layout.

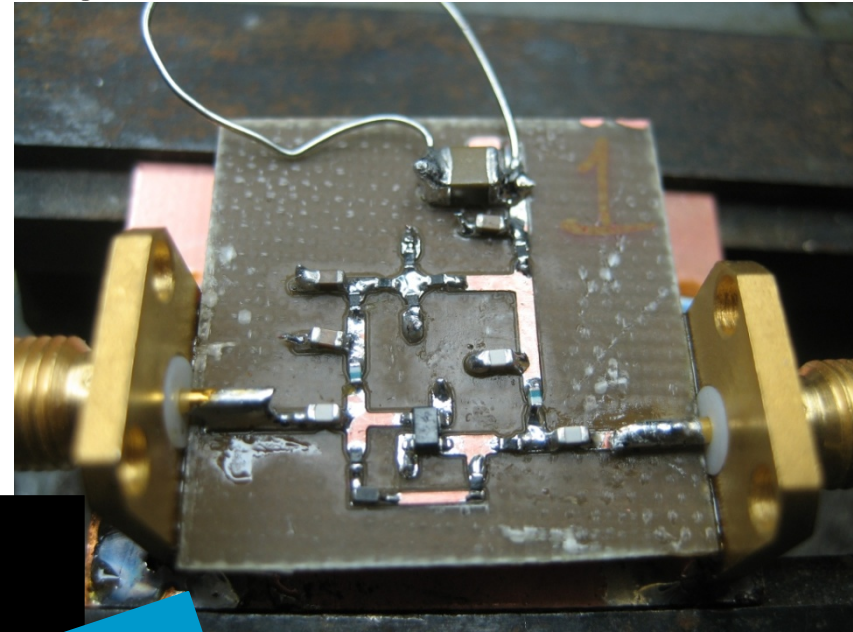
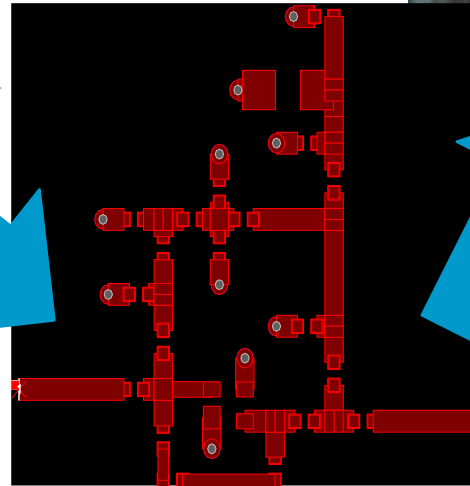
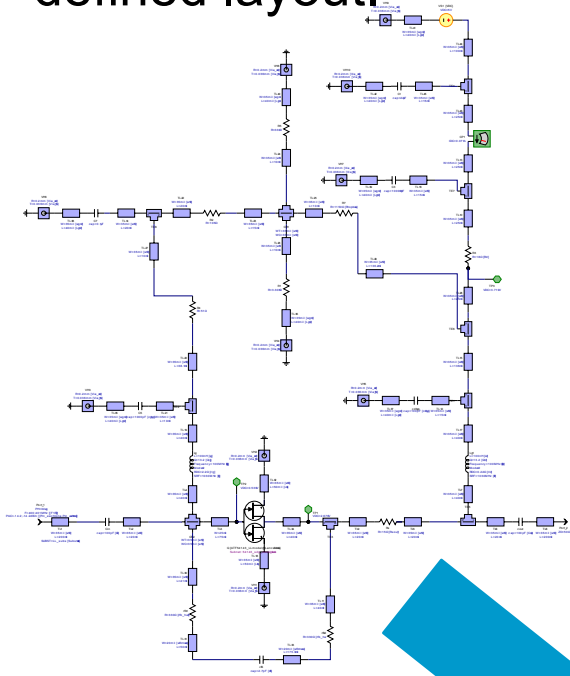

Amplifier Layout Design

Layout Is Everything

Add a Layout to the design and start with the picture below

TIP: Leave one wire in bias feedback unconnected and measure line lengths needed

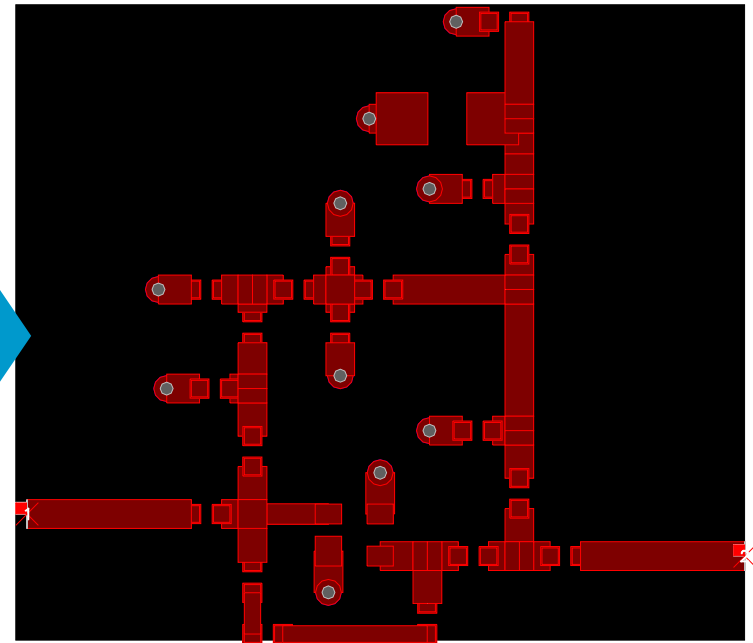
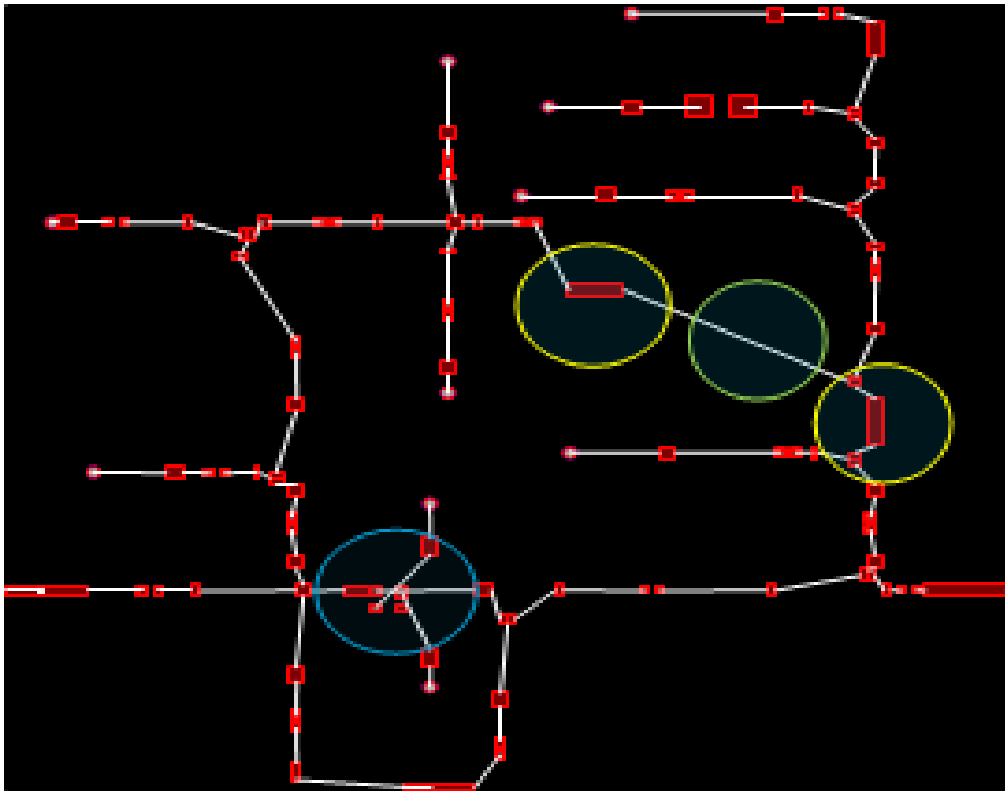

Amplifier Layout Design

Risk Mitigation

Why bother with all of the detailed layout work?

- Enhances the use of EM co-simulation
 - Without manually routed traces or copper you can study subtle design variations
 - **Tip: Don't worry about linear microstrip model validity warnings – if you're using Momentum GX, the copper is accounted for!**
 - **For best co-simulation, make anything you expect to change a variable in the equation block – this will keep schematics and co-simulation designs in sync and tied to one set of variables and will tune quickly without a new EM run**
- Design For Manufacturing, prototype in minutes (!)
 - Face it, we can never place components as close together as we would like
 - Create a production ready layout in your domain to handoff to your board designer
 - No argument if you follow the same rules, get the layout you want.
 - Easier reuse
 - Export DXF or Gerber

Amplifier Measured Results

Next we'll go over some key measurements that were made on two prototypes of the amplifier that we built for this presentation.

- We will show the differences between the measured units and the S2P transistor model as well as the Nonlinear model.



Measured vs. Modeled #1 (NL model)

General agreement is OK, perhaps a B- grade.

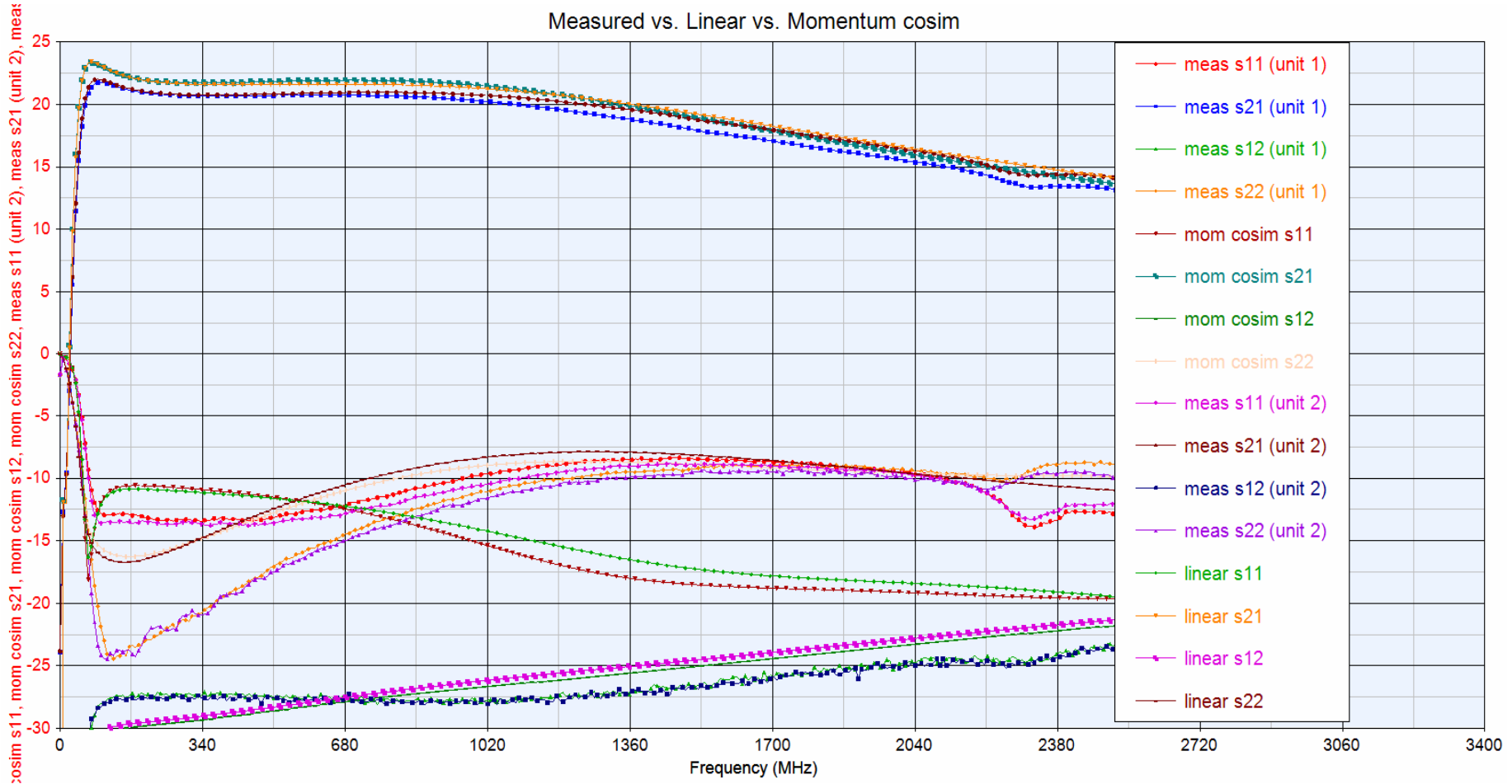

Measured vs. Modeled #2 (S2P data file)

Agreement better here (A-?), especially for S11: Note, this is at a *similar* bias point, not exactly the same. Agreement over specified band (150-450 MHz) is quite good.

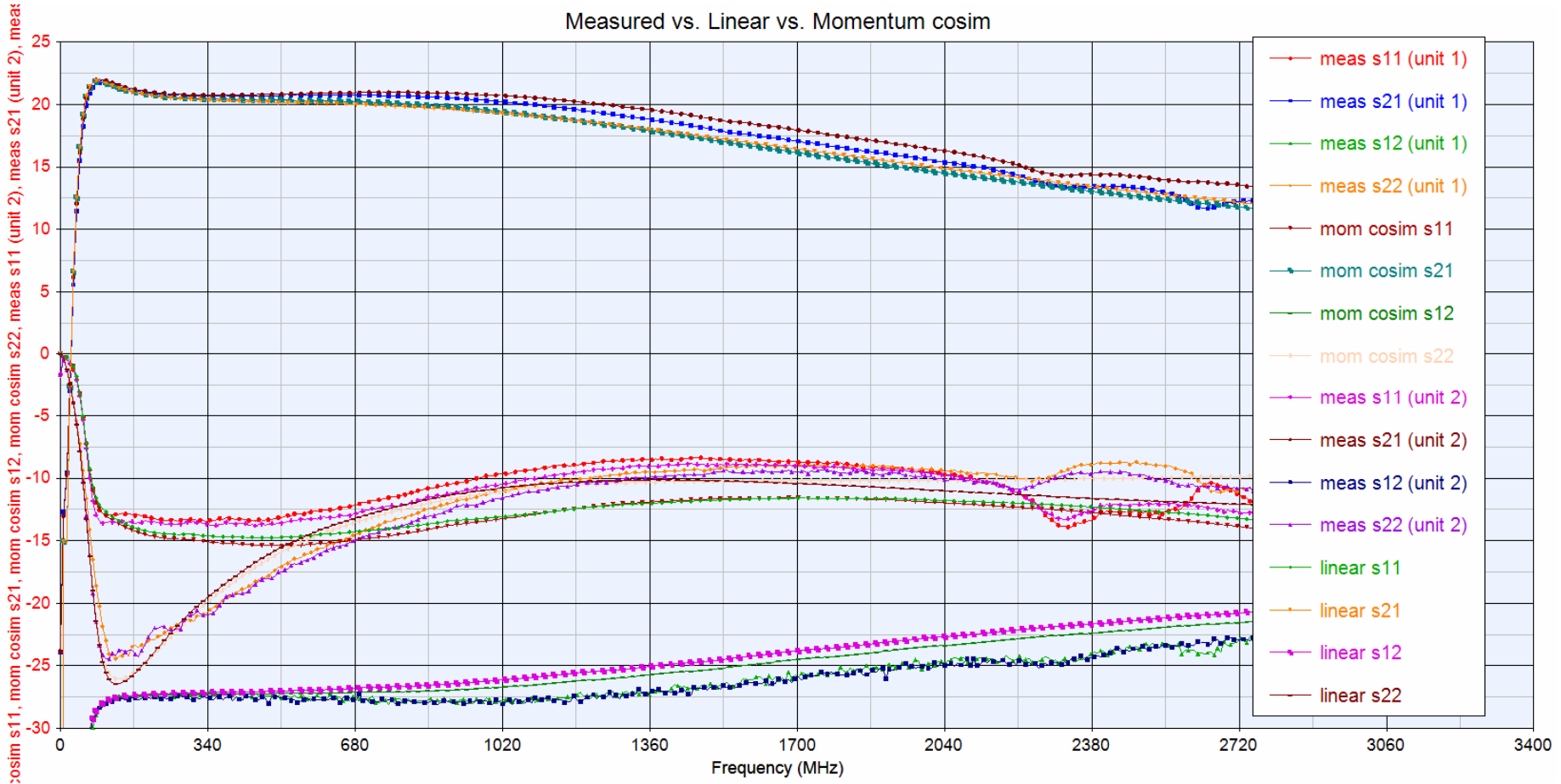

NF: Measured vs. Linear & Co-simulation (NL)

NF in model optimistic?

Note: Large spikes are due to local broadcast stations

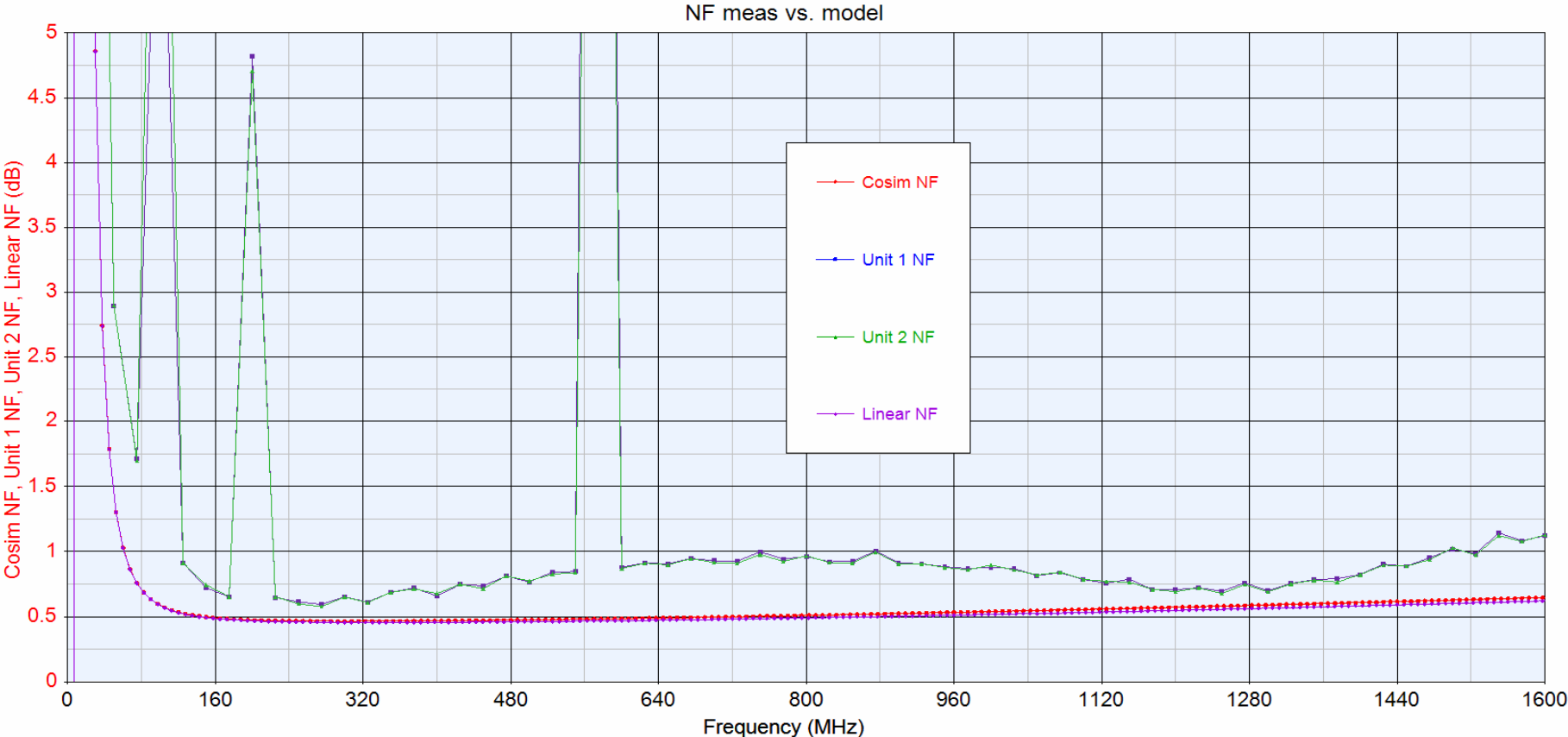

NF: Measured vs. Linear & Co-simulation (S2P)

S2P model again shows best agreement. Note: Large spikes are due to local broadcast stations

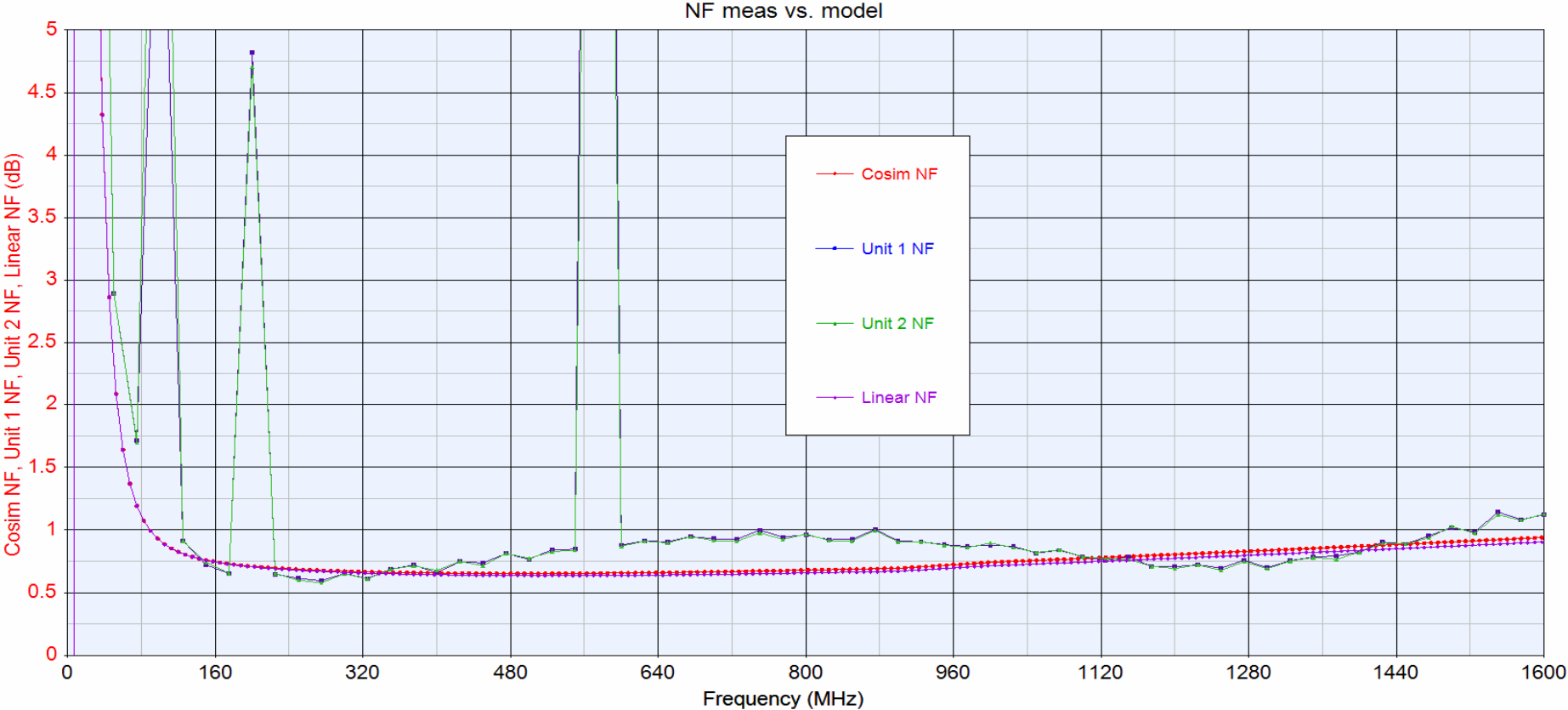

K: Measured vs. Linear & Co-simulation (NL)

Based on model only, this raises some real concern in the 1-1.5 GHz region.

K -- stability factor, measured vs. modeled

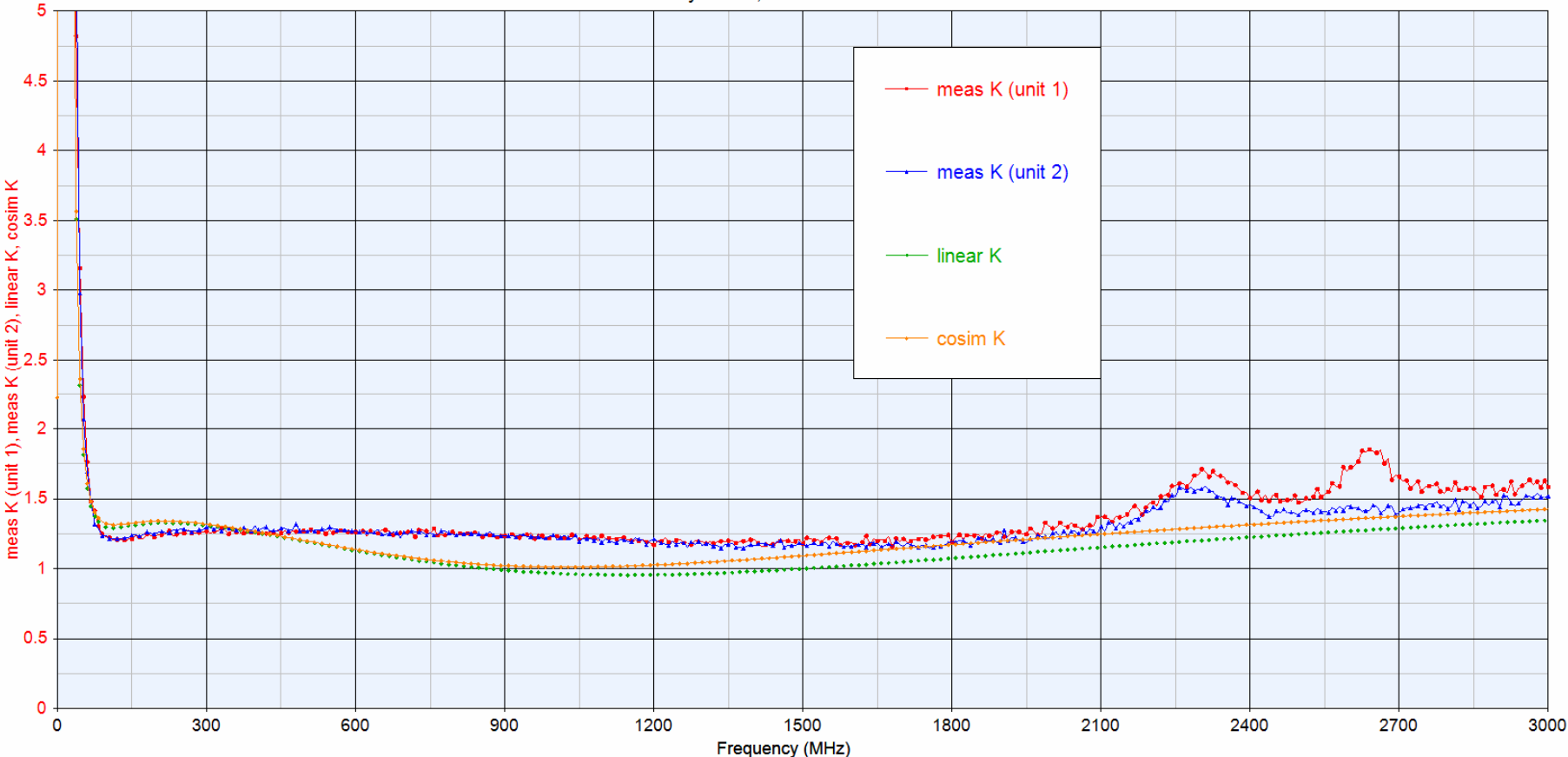

K: Measured vs. Linear & Co-simulation (S2P)

Again – S2P model shows best agreement

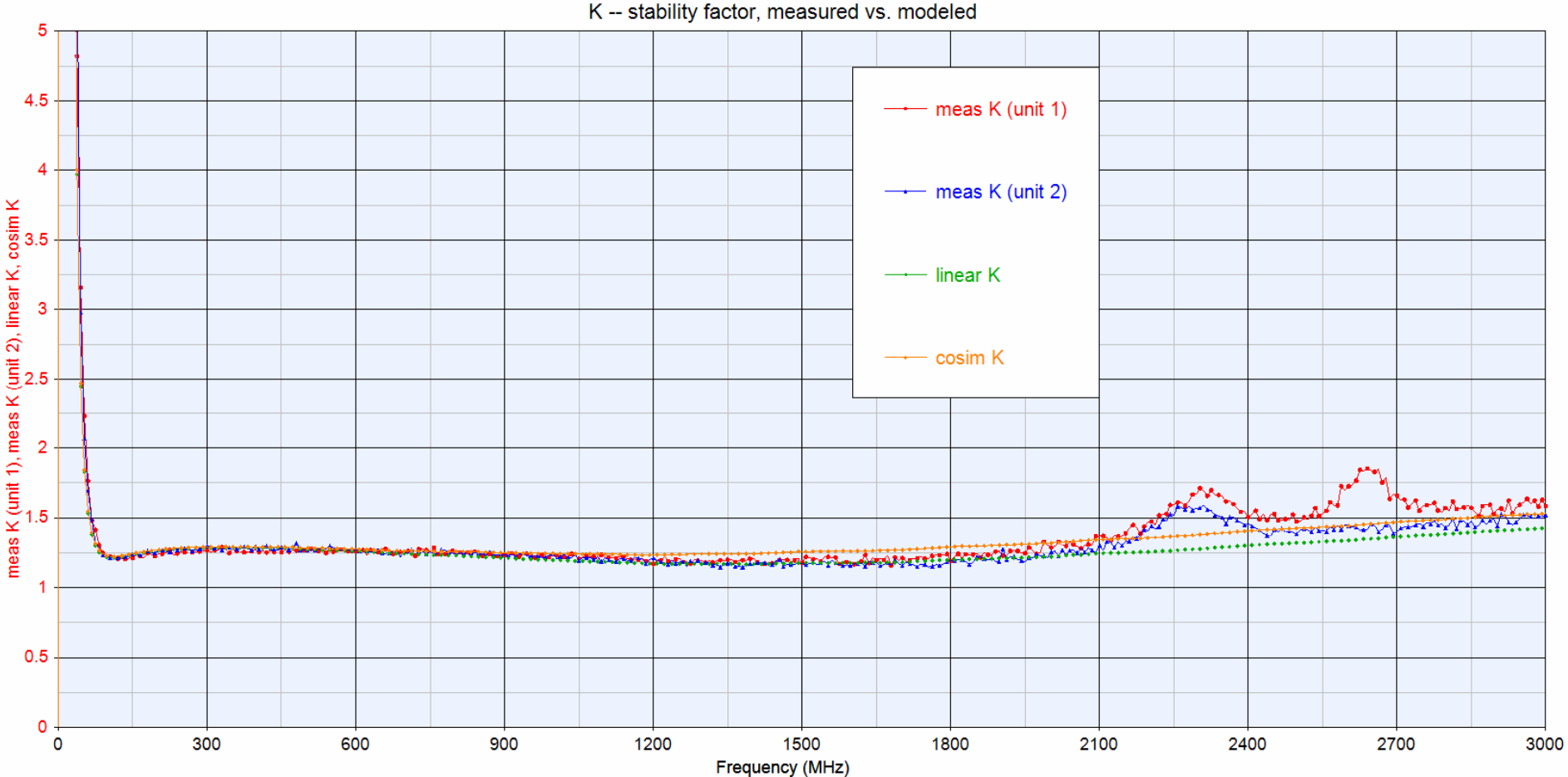

IMD: Measured vs. Linear & Co-simulation (NL)

Agreement for this case is somewhat poor, OIP3 pessimistic by 3.75 dB

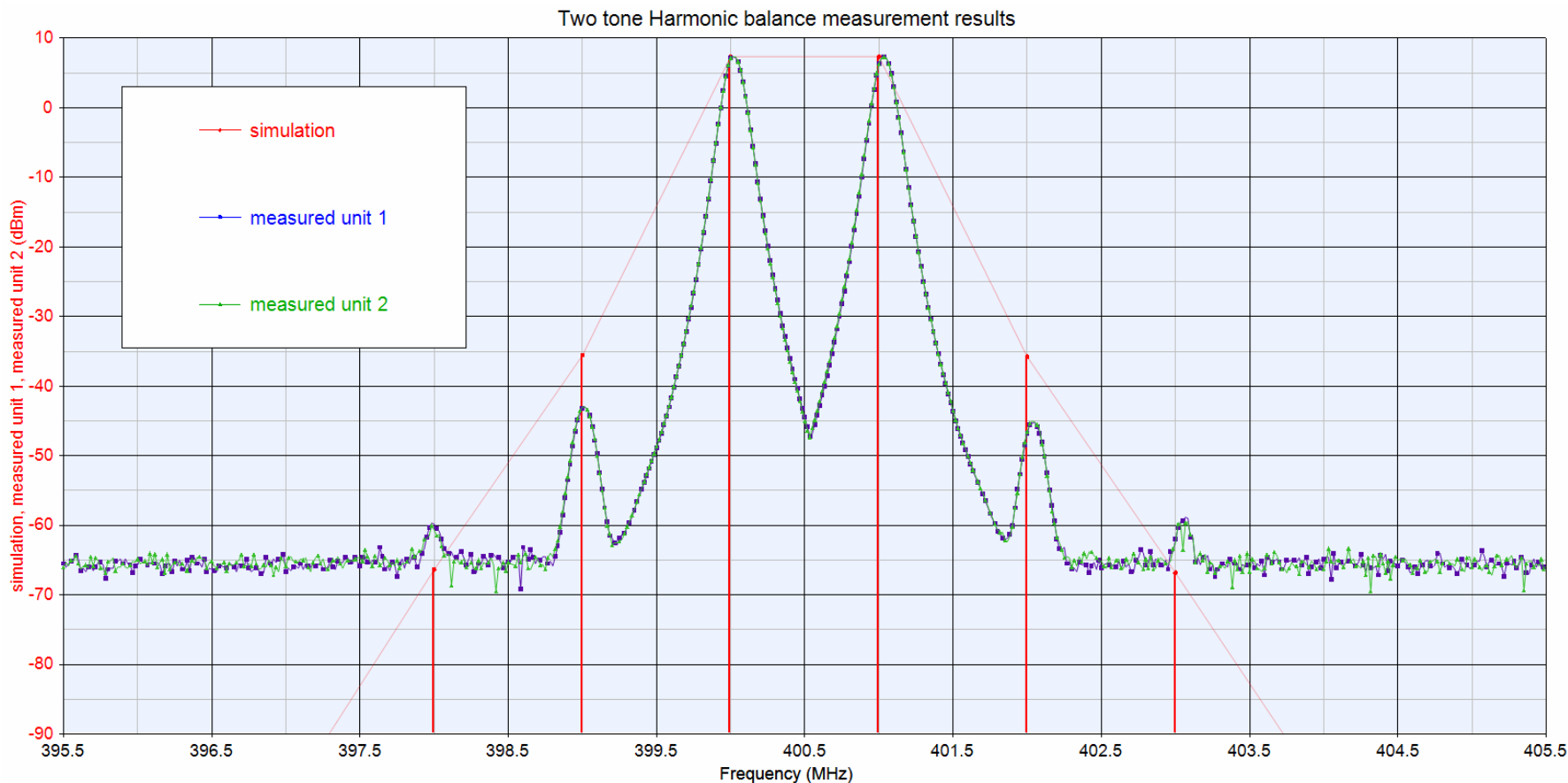

Amplifier Design Summary

- Key points that we've presented
 - Basic models can go a long way
 - Do what you can to quickly verify your models and then proceed with more detailed designs or refinements.
 - EM co-simulation is easy to incorporate, although over this frequency range the linear models and EM agreed quite well – two different views of the same circuit are always welcome. If there are any arbitrary copper geometries, this is key.
 - While it can seem labor intensive, creating sound “microwave” layouts starting at the schematic level can save time and improve efficiency in the long run.
- Next steps for this amplifier:
 - Look more closely at lumped models – inductors, to explain discrepancies
 - Consider improving margin on stability (K)
 - Try to understand discrepancies with nonlinear model

Amplifiers Design Tips

Tip: *for Bipolar amplifier designs:* A very useful estimate for P1dB, OIP3, optimum collector load impedance can be found here: “Calculate Intercept And Compression Points”, David Rosemarin, MICROWAVES & RF MAY 2000. This is very good sanity check for a device model and simulation

Tip: *for implementing the high-performance and famous “Norton” Lossless feedback amplifier:* Model the transformer using the 3-coupled inductor model

Printed Filter Design

In this section we'll discuss some techniques for designing and analyzing a few microstrip filters.

- Methods for designing “one off” topology filters that are similar to those covered easily with existing synthesis tools but not exactly
- Show the results of a filter synthesized in Genesys, analyzed with Momentum GX, and prototyped
- Show a very simple filter element that can be employed in special cases – with simulation and measured data to compare

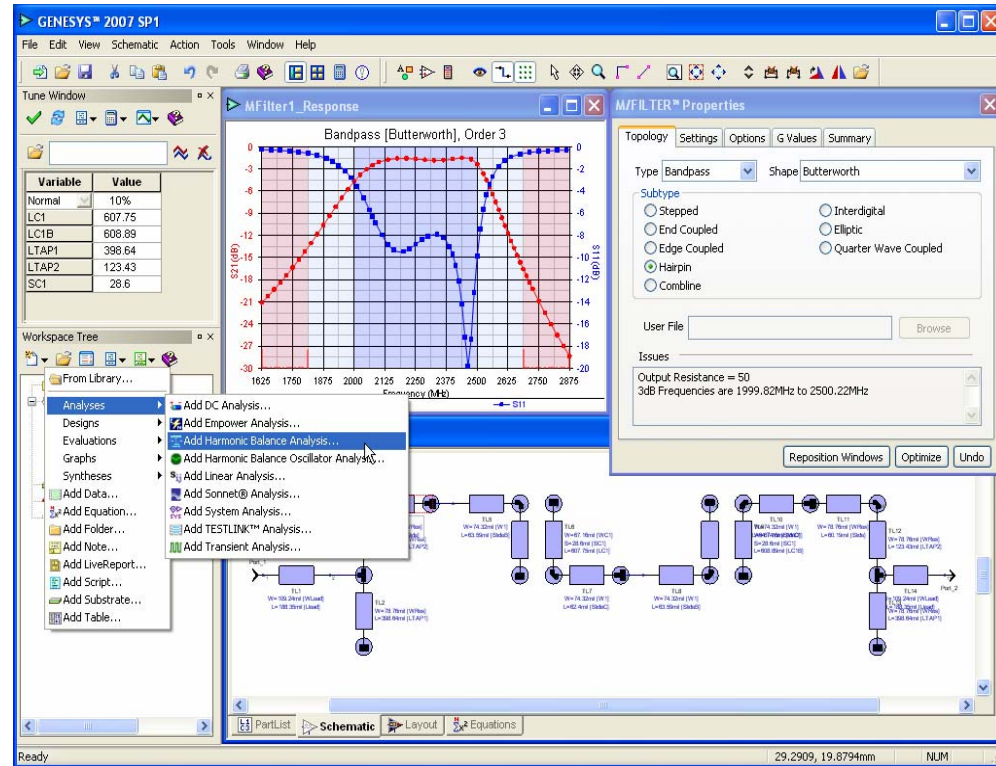

Printed Filter Design



There are an infinite number of shapes and sizes of printed filters, many can be derived from “standard” types such as the hairpin. The example given was for a very compact variation.

– The one on the previous slide is similar to "Miniaturized Hair-Pin resonator filters and their applications to receiver front-end mics", Kenichie Takahashi, et al. IEEE-MTT-S digest 1989

- Because of the complexity (number of elements and number of discontinuities), closed form expressions are unlikely.
- Best option is to make the whole physical model driven by algebraic equations. This allows careful, methodical manipulation and study of the effects of the different parameters. ***EM simulation is an absolute requirement.***

Printed Filter Design (without synthesis doing it all)

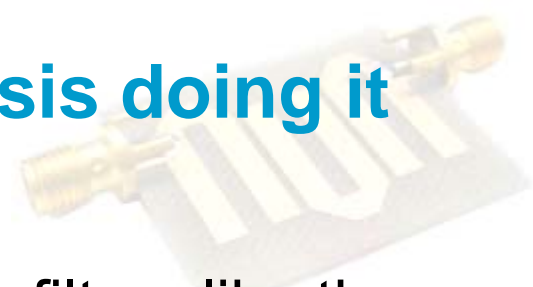

Here is the procedure I've used for coupled line filters like those in the previous slides with medium to narrow bandwidth:

- Design using standard equations, M/Filter, or S/Filter to come up with coupling values: Microwave Filters, Impedance-Matching Networks, and Coupling Structures, George Matthaei, Leo Young, and EMT Jones, 1964
- Design coupled line sections (whether full quarter wavelength or shortened) that match the required coupling in the center of the desired frequency band. I usually do this with a pair of lines in the EM simulator
- For Tapped filters, calculate the tap point at input and output resonators :Joseph S.Wong , “Microstrip Tapped-Line Filter Design”, IEEE Trans.MTT-27 , 1 ,1979 , 44-50.
 - Analyze using EM simulation
 - Iterate primarily on tap point and end resonator discontinuities
 - Not the best procedure, but it will get you there

Microstrip Filters → Use Synthesis M/Filter

Note: This was a very quick prototype to test a new CNC prototyping machine. The original design specifications weren't practical, but it was a starting point.

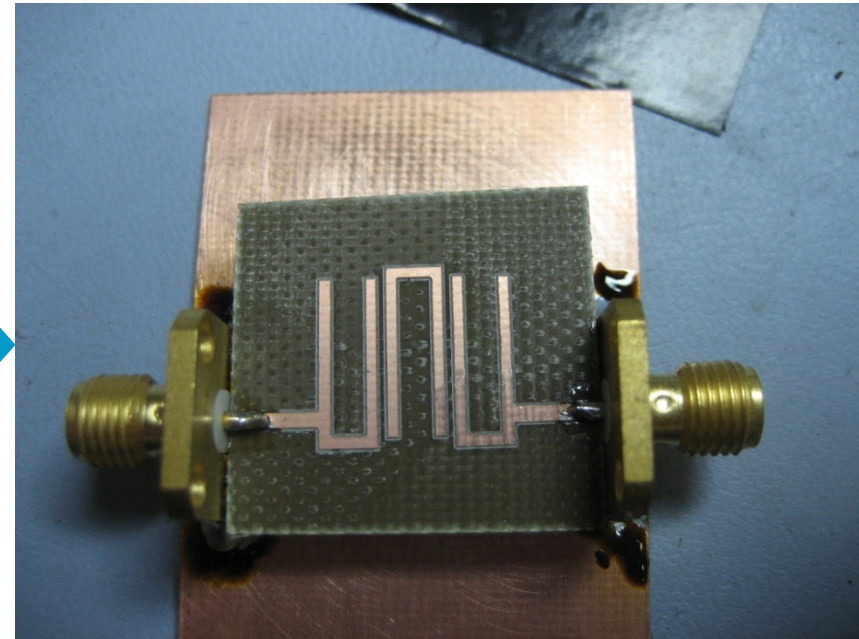
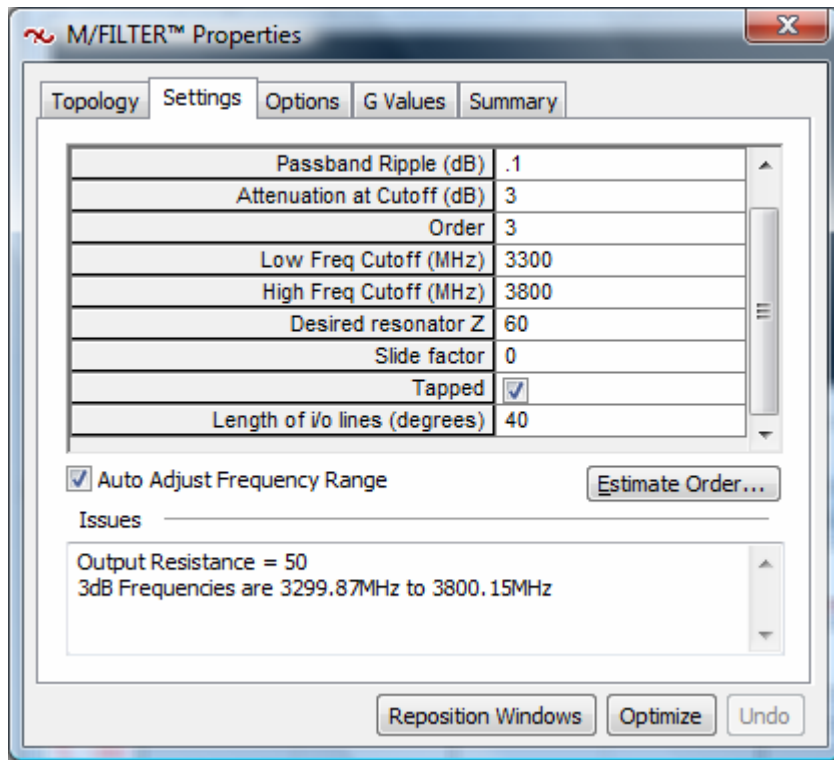

Microstrip Filters → Use Synthesis

Two prototypes of the synthesized filter compared to a Momentum GX simulation

Er and TanD were adjusted to enhance agreement (both well within the reasonable range for FR4), and used in later designs with this material

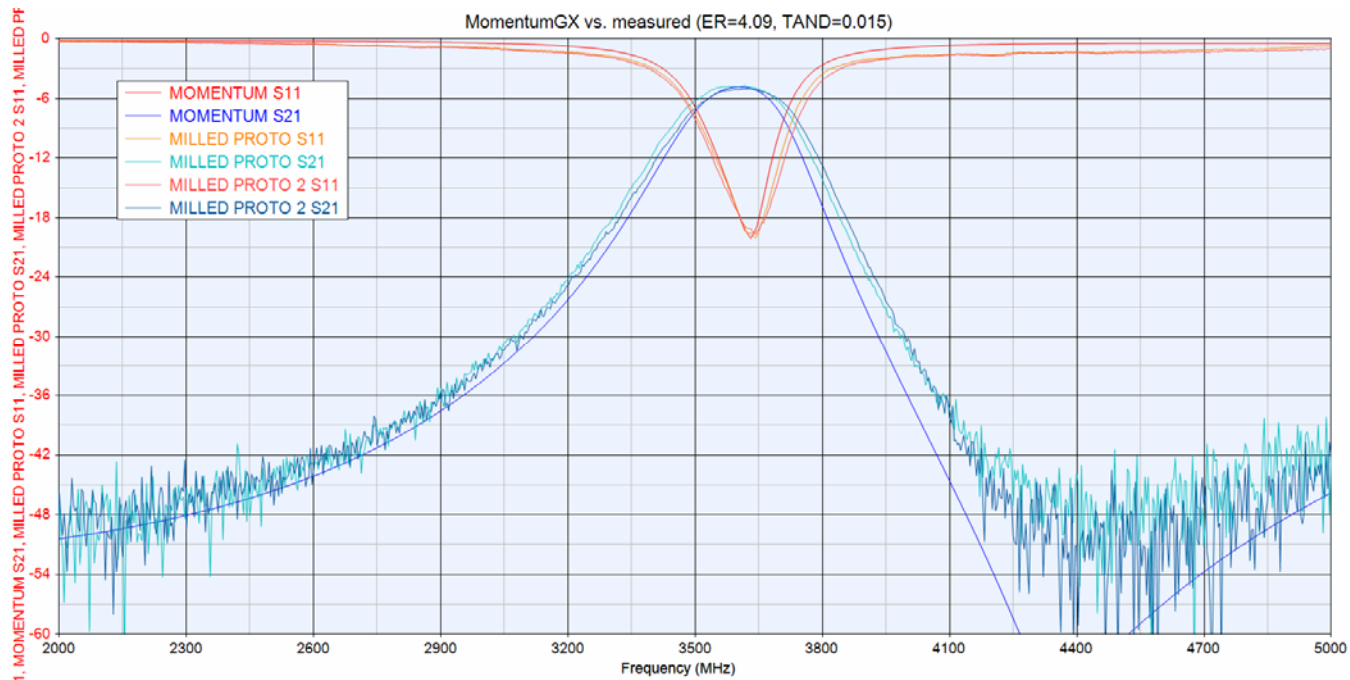

Microstrip Filters

Simpler Basic Elements

A very simple filter

- In some cases you need just a little rejection at a particular frequency
 - Suppress a reentrant mode in another filter
 - Harmonic or LO rejection
 - ESD, lightning protection, DC return
- Try this: a very basic tapped quarter wave resonator
 - Z_0 of the resonator and the tap point affect the Q
 - Tap point affects the notch frequency
 - View as shunt open/short stubs in parallel
 - Always resonate together at Length total = $\lambda/4$

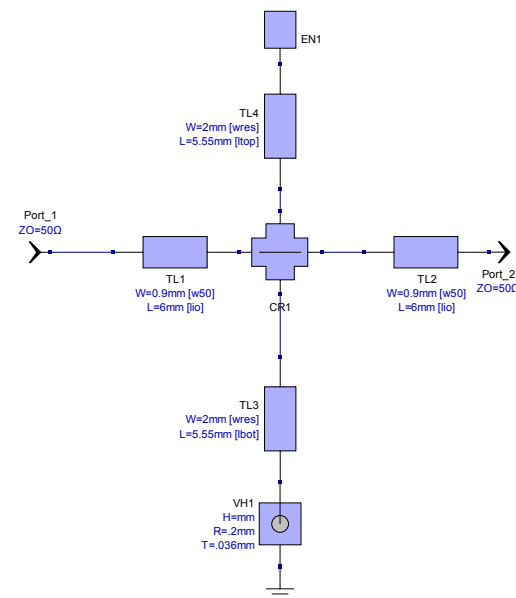

Simple Microstrip Filter

A very simple filter

MomentumGX and sweeps!

- New in Genesys 2008: Auto-connect and center

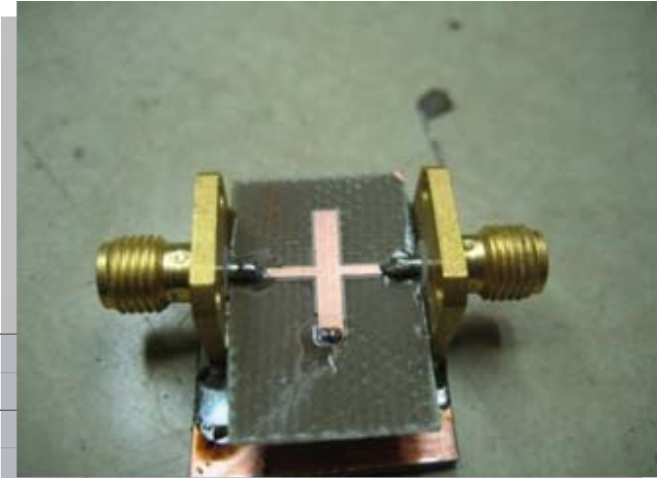

Momentum Tap angle sweep of simple filter, 40, 45, 50, 55, 60 degree tap points

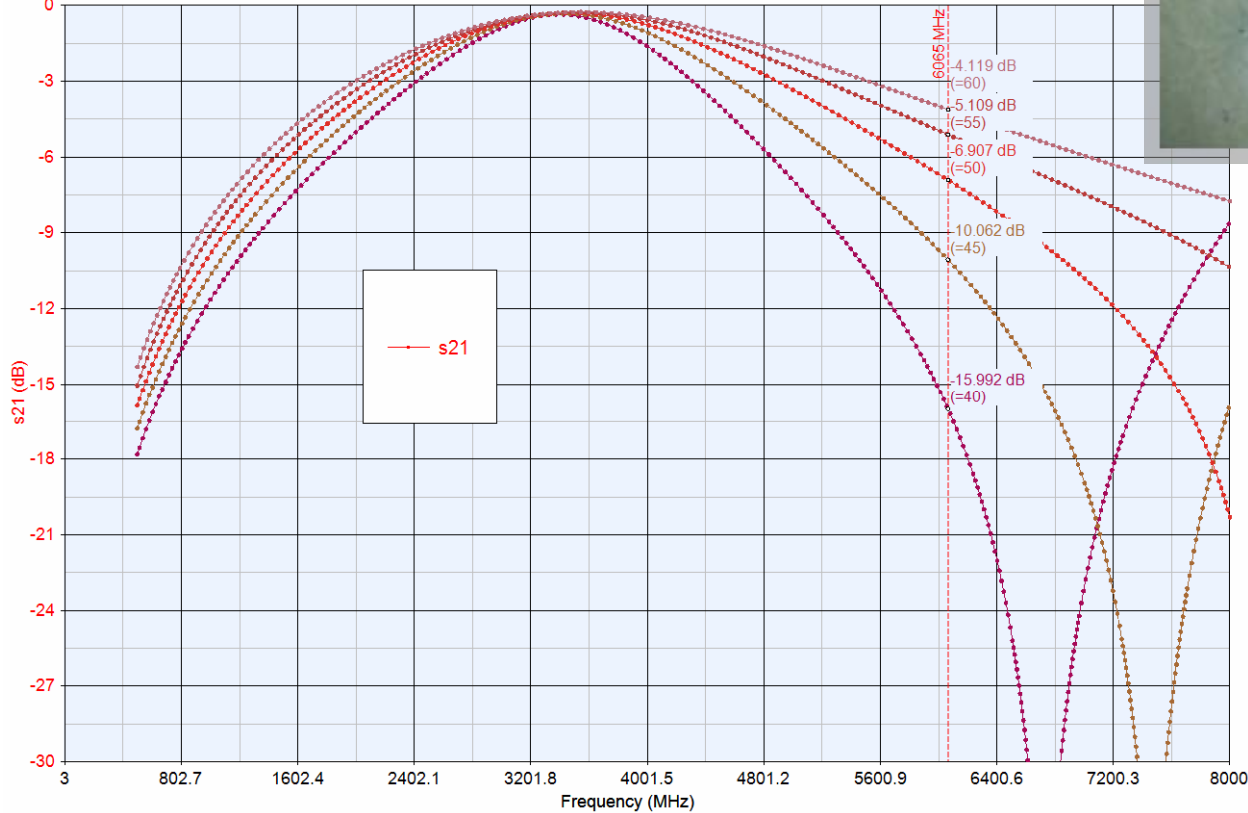

Simple Microstrip Filter

Good agreement between EM and Meas. :Tap@45 degrees

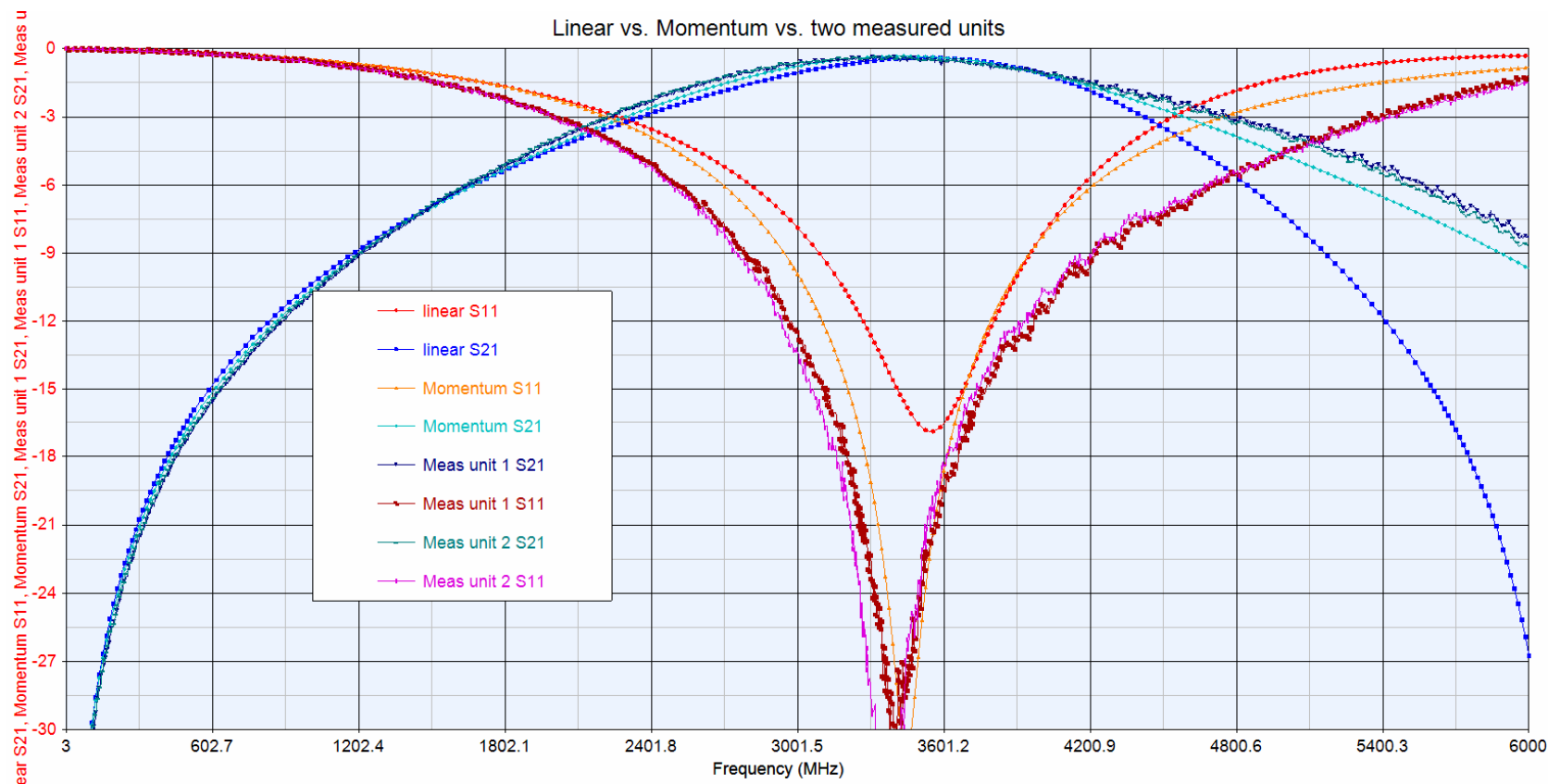

Basic Patch Antenna Design in Agilent Genesys

Patch antennas are very attractive because they are relatively low cost, easy to manufacture, and have a low profile. They also integrate well with many products.

- Unfortunately, basic patch antenna elements constructed on standard circuit board material typically exhibit a very narrow bandwidth which presents problems both in design and production.

In this section we will discuss how I personally approach designing basic patch antennas.

- Basic element design
 - Measured vs. modeled return loss for a single element
- Array design
- Comments on advanced topics such as broadbanding

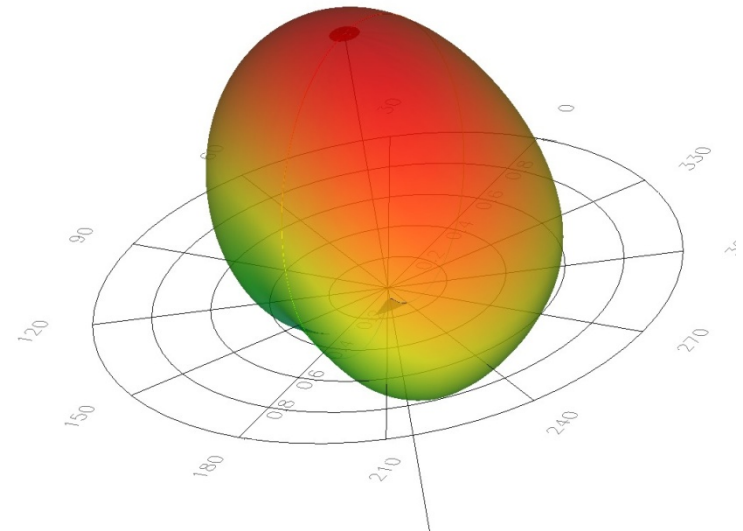
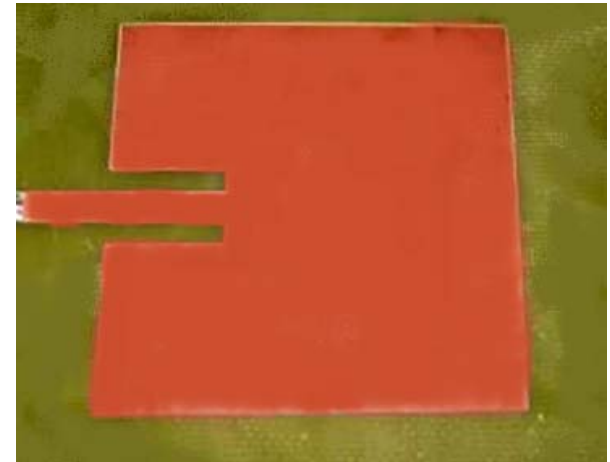

Patch Antenna Design in Agilent Genesys

Patch element design:

- Patch elements take the form of almost any shape you can imagine. We will focus on rectangular and square patches, one half wavelength long.
- Patch elements can be fed by many different means. We will focus on directly attaching a feedline to the edge of a patch antenna.
- Patch element matching can be done in many ways. We will focus on one technique, the inset feed.

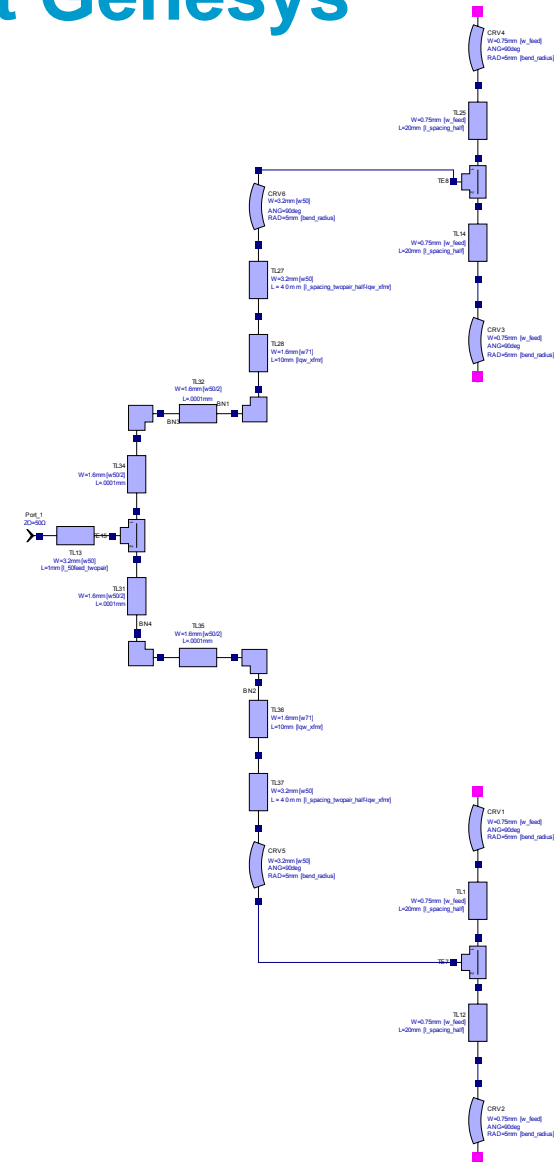

Patch Antenna Elements

Patch elements in this discussion have these characteristics:

- High input impedance (observed at the edge of the patch)
 - Virtual short at the center of the patch
- Narrow impedance bandwidth, < 10%, often ~1-2%

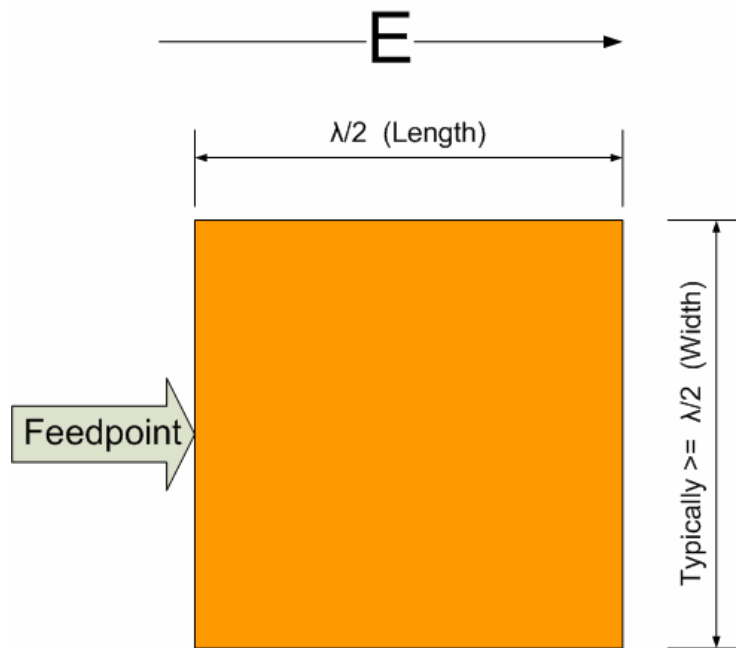

Patch Antenna Design in Agilent Genesys

Inset Feed

The inset feed uses a method similar to the familiar “tap” used in filter resonators for impedance transformation.

- Various references in the literature suggest that the transformation between the high edge impedance and $0 W$ follows a \cos^2 relationship with distance, others suggest it is \cos^4 .
- My design flow for a patch element is roughly as follows:
 - Use tool of choice to estimate the patch dimensions (without feed)
 - Simulate and adjust basic patch and determine the impedance at the edge
 - Use the aforementioned impedance relationships to select the initial inset “depth”, i.e. the amount that the microstrip feedline intrudes into the patch
 - iterate as necessary

Patch Antenna Design in Agilent Genesys

Patch element design

- Another simple schematic
 - Several parameter variations

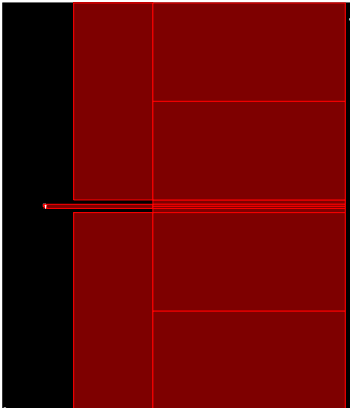
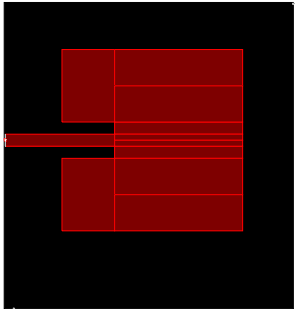
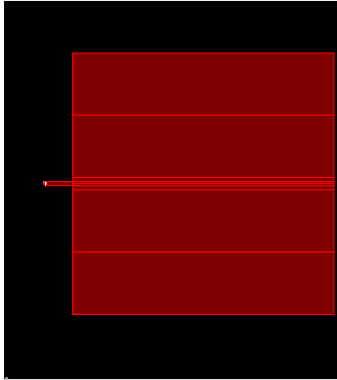
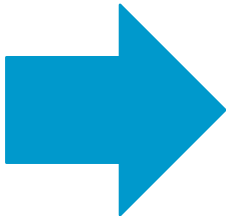
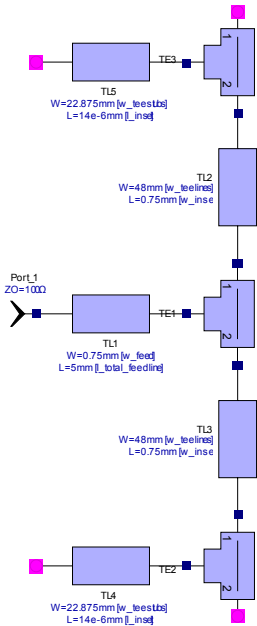

Patch Antenna Experimental Design & Prototype

1.5 GHz square patch on 1.6 mm thick FR4

- Match to 50 ohms using inset



Patch Antenna Experimental Design & Prototype

1.5 GHz square patch on 1.6 mm thick FR4

- Very good agreement over wide measurement range

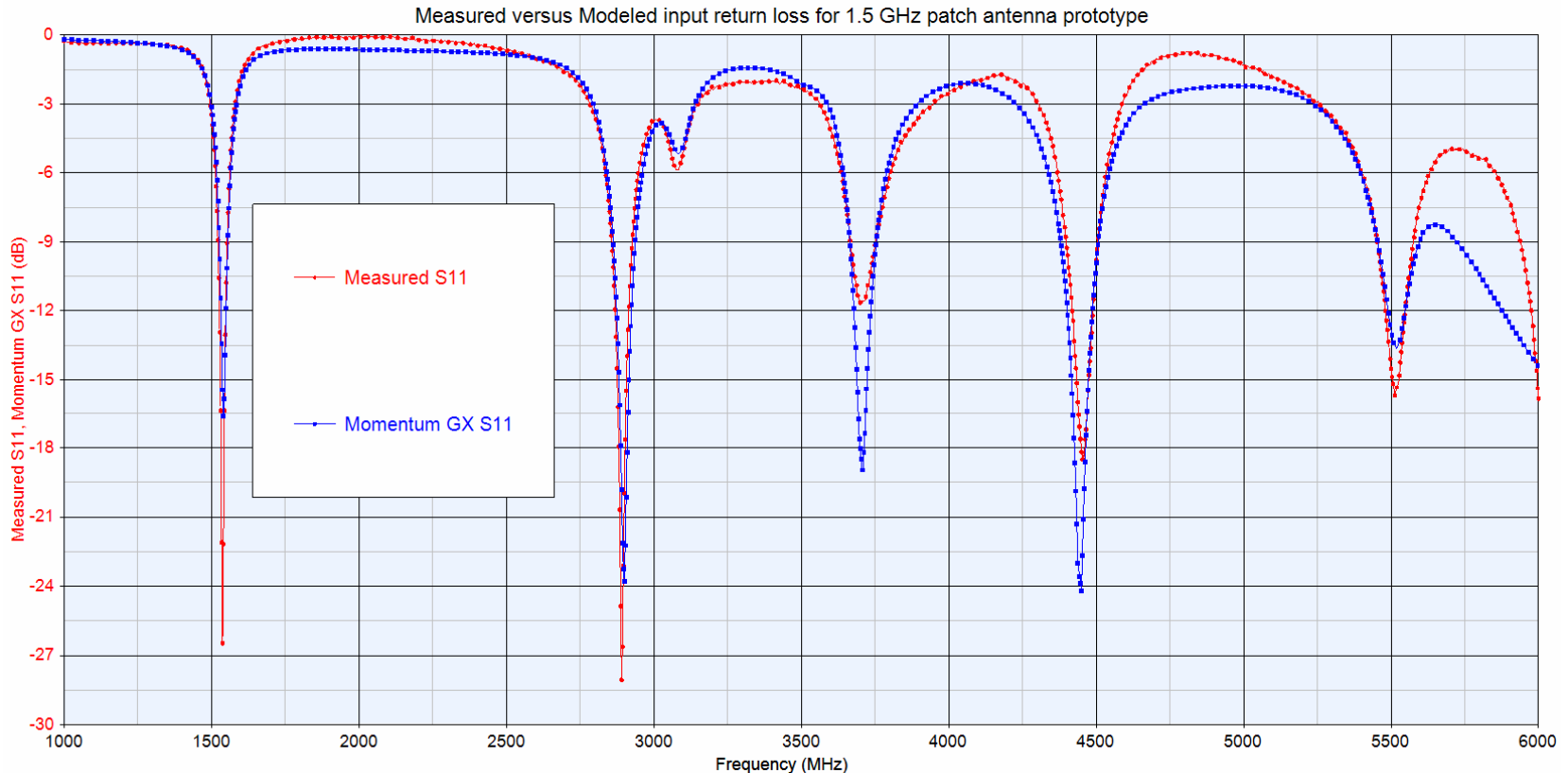

Patch Antenna Experimental Design & Prototype

1.5 GHz square patch on 1.6 mm thick FR4

- Very narrowband! – this antenna not really viable on FR4

Measured versus Modeled input return loss for 1.5 GHz patch antenna prototype

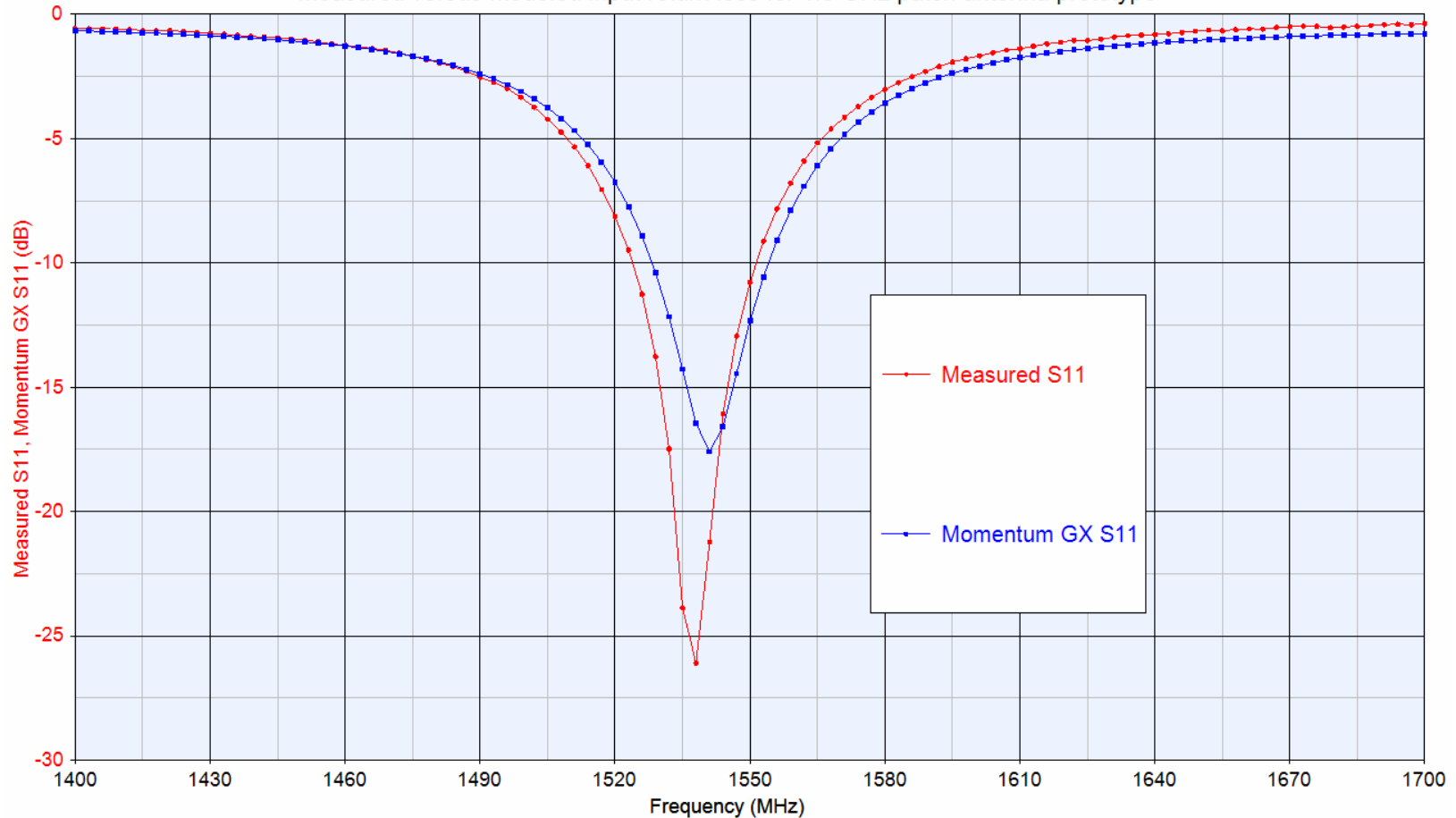

Patch antenna bonus: New Feature for 2008

Layouts can auto-align and center between sweeps:

Parametric Analysis with MomentumGX! -> find a better match

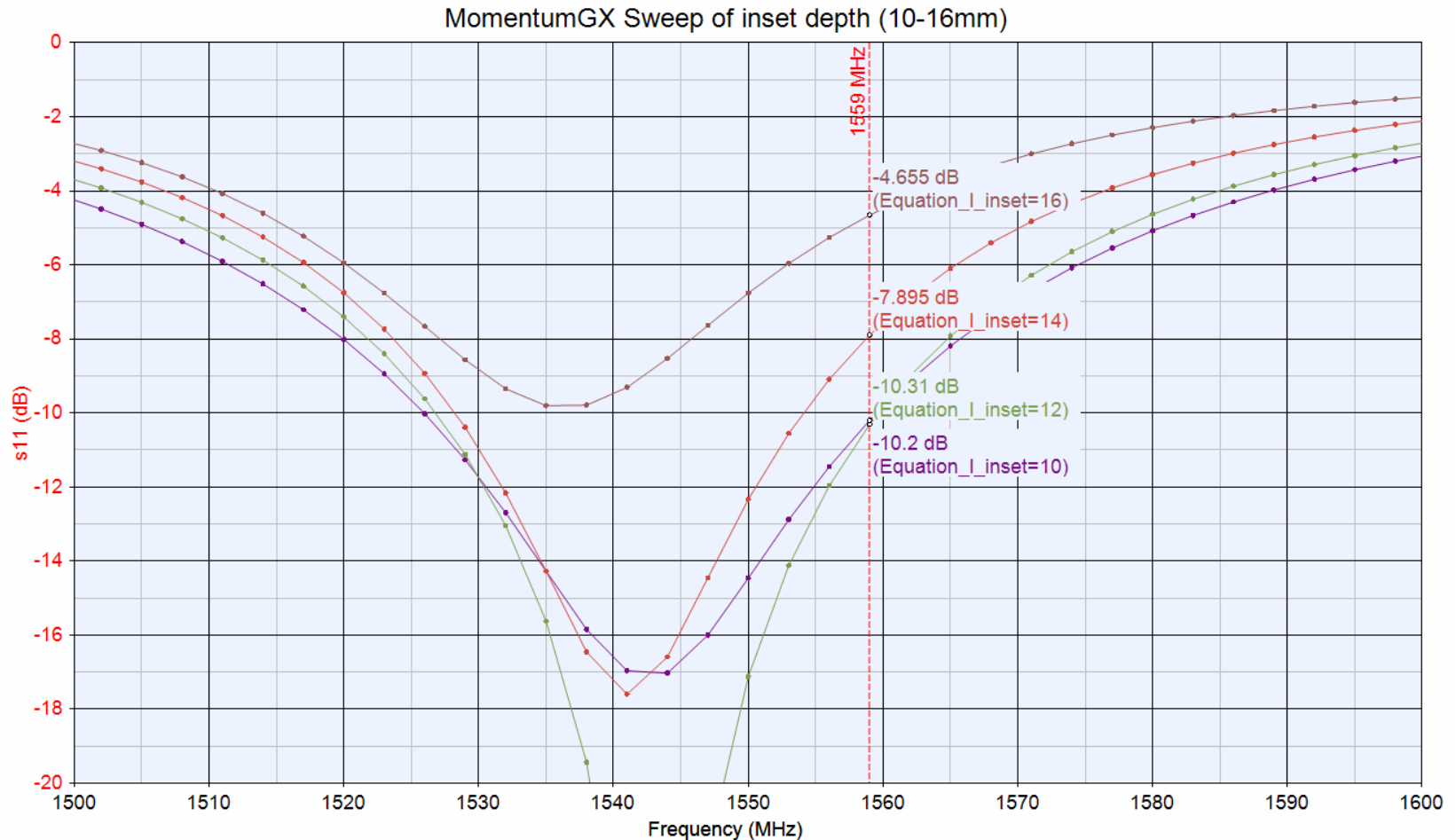

Patch Antenna Arrays

Arrays of patch elements for higher gain and directivity

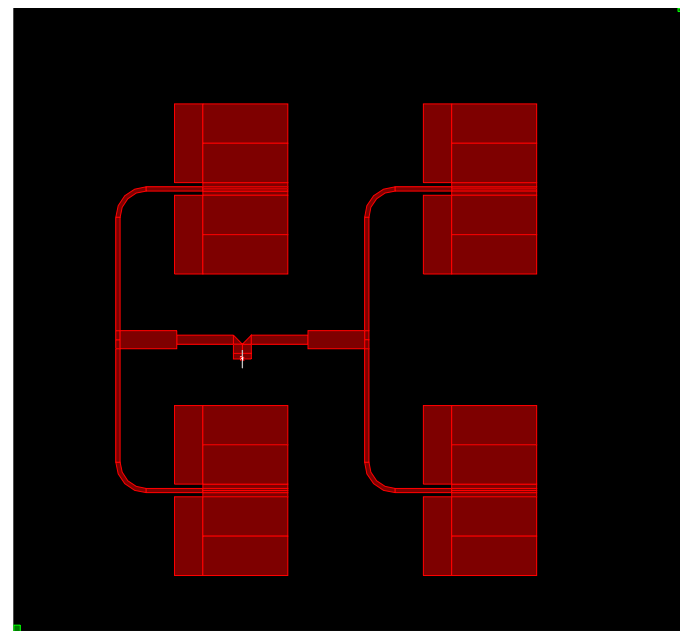
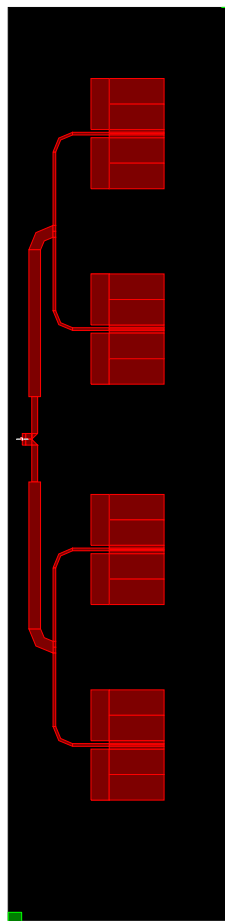
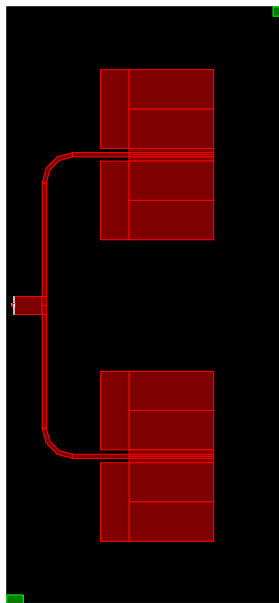

Patch Antenna Arrays

Arrays characteristics

- Arrangement of array determines antenna pattern
- Number of elements, if spaced appropriately, determines gain
- Once the basic number of elements is determined, the feed network must be designed.
- Losses in the feed/distribution network will reduce overall efficiency

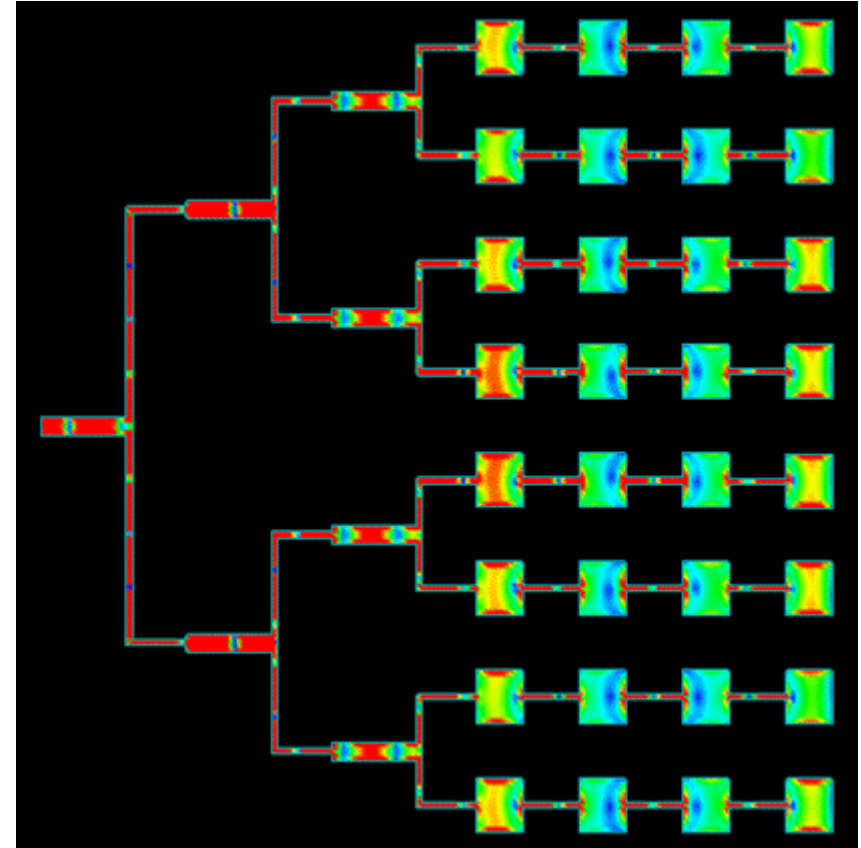

Patch Antenna Arrays

Feed Networks

Commonly used “corporate” feed.

- Simplest approach: all patch elements fed **equal amplitude and phase** (*symmetry!*)
- Since patch impedance is already high, often individual elements are fed by 100 Ω transmission lines
 - Pairs of elements are then fed in parallel
 - $(100\ \Omega || 100\ \Omega = 50\ \Omega)$
 - Note: the length of these 100 ohm lines is not critical as long as they are equal
 - Higher order arrays (> 2 patches) often use quarter wave transformers to parallel 50 ohm sub-arrays
 - After blocks are optimized, cut and paste to make larger arrays

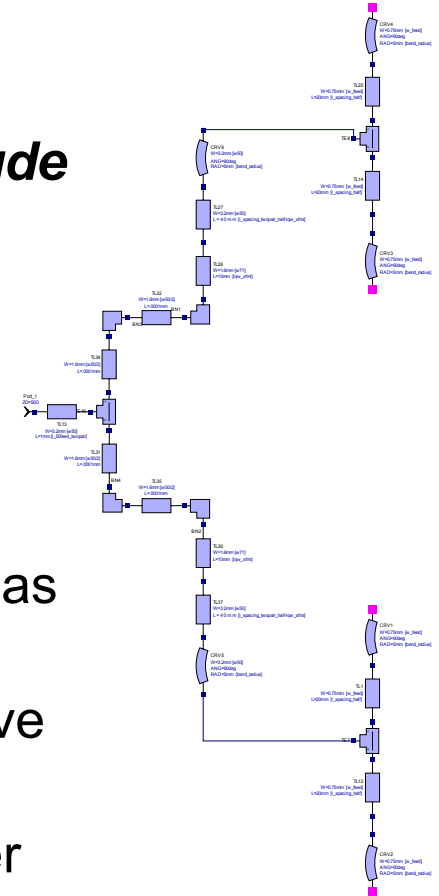

Patch Antenna Arrays

Feed Networks

Feed networks can be analyzed with models or EM

- Very easy to parameterize all aspects of the array using the pallet of shapes available in the microstrip element catalog

Tip: To create elements that don't exist, you simply need to figure out how to create the copper shape using more basic ones (better than drawing by hand). Example: compensated Tee connection manually:

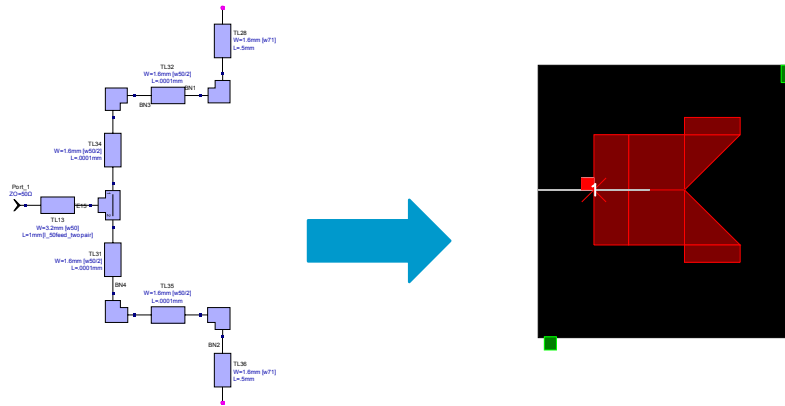

Note: linear analysis of the microstrip schematic will not be valid, but it will create the proper shape for EM analysis

Patch Antennas

Advanced Topics

Broadbanding

- Many techniques in the literature for broadbanding
 - Thicker substrates (can lead to lower efficiency due to surface wave loss)
 - Lower dielectric constant substrates (air, foam...)
 - Aperture coupling
 - Notches, slots.
 - Parasitic elements on other layers
 - Dual/multiband elements

Beam steering

- Can be accomplished by tailoring phase/magnitude of signal to/from each element
- Special antennas can scan the beam by scanning frequency

RF Board Level Design

Wrap-up

In this presentation I have tried to share some insight into how I attack board-level RF design. Here is a summary of some of the key tips:

- In many cases, layout is everything, don't make it an afterthought
- Often simple models can give good results, refine yours as you see fit
- Don't risk too much on poorly controlled board materials
- With good EM analysis such as Momentum GX, don't be afraid of arbitrary geometries. Use your creativity to generate shapes automatically with building blocks available
- Parameterize everything that you can, it makes for a cleaner design and simulation setup that is easy to reuse
- Measure your final circuits or prototypes, even if just a portion of the circuit!

RFdude.com LLC

Resources Used in Preparing Examples:

Software:

- Agilent Genesys EDA environment
- Momentum GX 3D-planar EM simulator
- S-parameter linear simulator
- Harmonic balance non-linear simulator
- M/Filter distributed filter synthesis for microwave applications
- Gerber file export
- Testlink instrument data import

Hardware:

- HP8753B VNA
- HP8970B Noise Figure meter with Noisecom NC346KA noise source
- HP8562A Spectrum Analyzer
- HP8642M Signal generators (two)
- Accurate350 PCB prototyping machine run by DeskCNC software (Genesys Gerber files imported directly)

Additional Resources

For more information on:

- ✓ *Agilent Genesys & Momentum GX*
- ✓ And to request a *FREE* evaluation license please follow this link:
- <http://eesof.tm.agilent.com/products/genesys/>

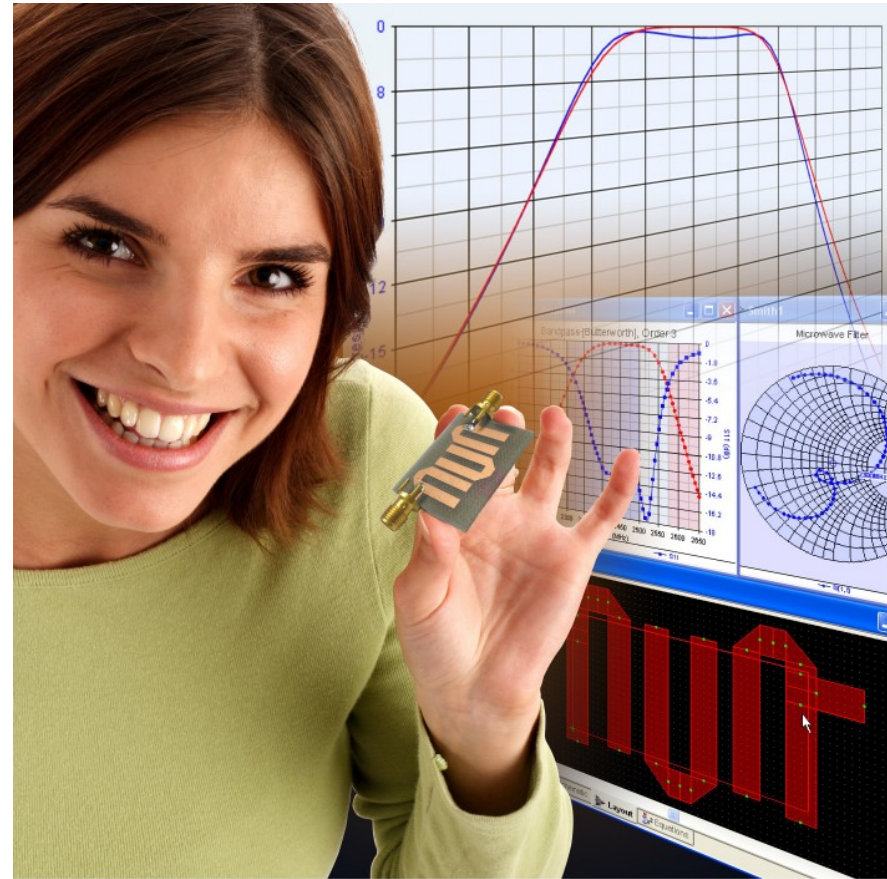

Thank You