

ASMT-Jx3x

3W Mini Power LED Light Source



Data Sheet



Lead (Pb) Free
RoHS 6 fully
compliant



Description

The 3W Mini Power LED Light Source is a high performance energy efficient device which can handle high thermal and high driving current. Option with electrically isolated metal slug is also available.

The White Mini Power LED is available in the range of color temperature from 2700K to 10000K.

The low profile package design and ultra small footprint is suitable for a wide variety of applications especially where space and height is a constraint.

The package is compatible with reflow soldering process. To facilitate easy pick & place assembly, the LEDs are packed in EIA-compliant tape and reel.

Features

- Available in Red, Red Orange, Amber, Green, Blue, Royal Blue, Cool White, Neutral White and Warm White
- Small footprint and low profile
- Symmetrical outline
- Energy efficient
- Direct heat transfer from metal slug to mother board
- Compatible with reflow soldering process
- High current operation
- Long operation life
- Wide viewing angle
- Silicone encapsulation
- Non-ESD sensitive (threshold > 16kV)
- MSL 1 products

Applications

- Sign backlight
- Safety, exit and emergency sign lightings
- Specialty lighting such as task lighting and reading lights
- Retail display
- Commercial lighting
- Accent or marker lightings, strip or step lightings
- Portable lightings, bicycle head lamp, torch lights.
- Decorative lighting
- Architectural lighting
- Pathway lighting
- Street lighting
- Pedestrian street lighting
- Tunnel lighting

CAUTION: Customer is advised to keep the LEDs in the MBB when not in use as prolonged exposure to environment might cause the silver plated leads to tarnish, which might cause difficulties in soldering.

Package Dimensions

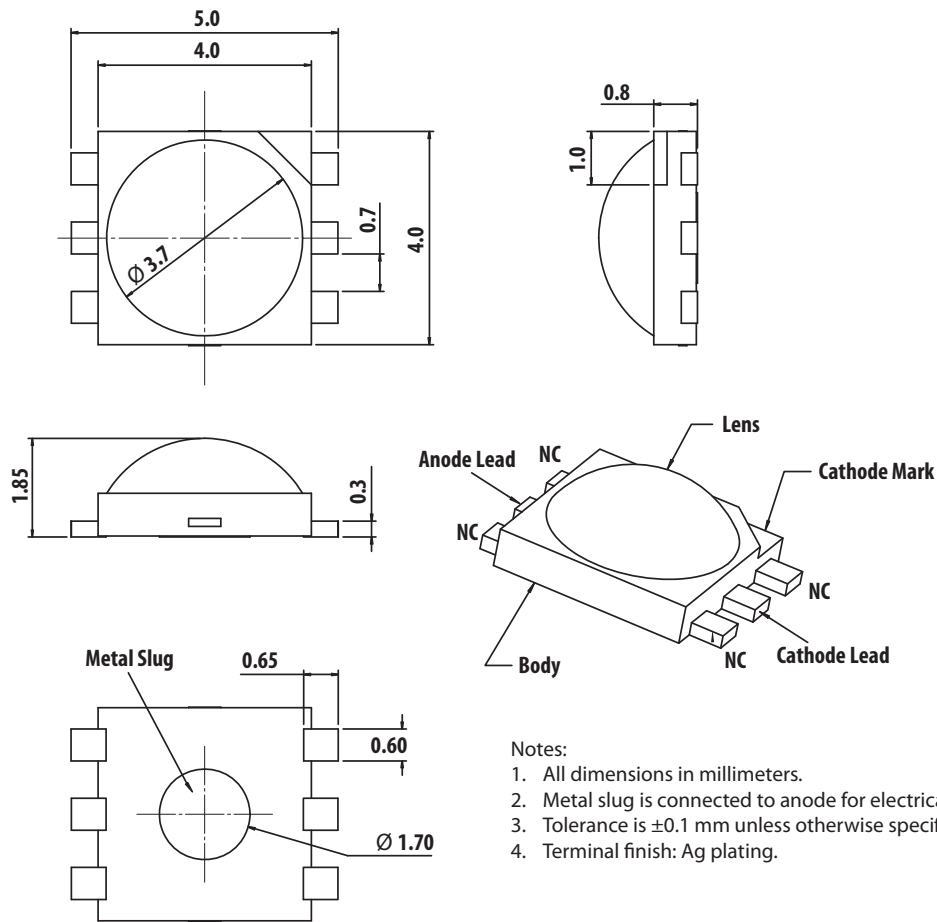

Notes:

1. All dimensions in millimeters.
2. Metal slug is connected to anode for electrically non-isolated option.
3. Tolerance is ± 0.1 mm unless otherwise specified.
4. Terminal finish: Ag plating.

Device Selection Guide ($T_j = 25^\circ\text{C}$)

| Part Number | Color | Luminous Flux (lm) / Radiometric Power (mW), Φ_V ^[1,2] | | | Test Current (mA) | Dice Technology | Electrically Isolated Metal Slug |
|-----------------|---------------|--|--------|--------|-------------------|-----------------|----------------------------------|
| | | Min. | Typ. | Max. | | | |
| ASMT-JR30-ARS01 | Red | 39.8 | 45.0 | 67.2 | 350 | AllInGaP | No |
| ASMT-JH30-ARS01 | Red Orange | 39.8 | 45.0 | 67.2 | 350 | AllInGaP | No |
| ASMT-JA30-ARS01 | Amber | 39.8 | 45.0 | 67.2 | 350 | AllInGaP | No |
| ASMT-JG31-NST01 | Green | 51.7 | 70.0 | 87.4 | 350 | InGaN | Yes |
| ASMT-JB31-NMP01 | Blue | 13.9 | 20.0 | 30.6 | 350 | InGaN | Yes |
| ASMT-JL31-NPQ01 | Royal Blue | 355 mW | 435 mW | 515 mW | 350 | InGaN | Yes |
| ASMT-JW31-NTV01 | Cool White | 67.2 | 85.0 | 113.6 | 350 | InGaN | Yes |
| ASMT-JW31-NUV01 | | 87.4 | 95.0 | 113.6 | 350 | InGaN | Yes |
| ASMT-JN31-NTV01 | Neutral White | 67.2 | 85.0 | 113.6 | 350 | InGaN | Yes |
| ASMT-JN31-NUV01 | | 87.4 | 95.0 | 113.6 | 350 | InGaN | Yes |
| ASMT-JY31-NSU01 | Warm White | 51.7 | 70.0 | 99.6 | 350 | InGaN | Yes |

Notes:

1. Φ_V is the total luminous flux / radiometric power output as measured with an integrating sphere at 25ms mono pulse condition.
2. Flux tolerance is $\pm 10\%$

Part Numbering System

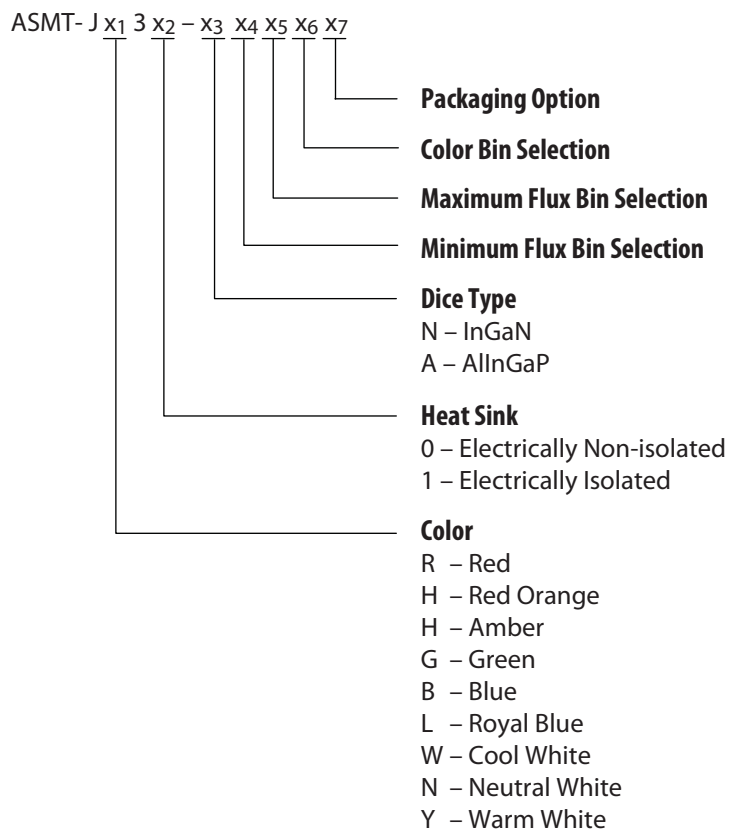

Note:

1. Please refer to Page 10 for selection details.

Absolute Maximum Ratings

| Parameter | AllInGaP | InGaN | Units |
|--|---------------------|--------------|-------|
| DC Forward Current ^[1] | 700 | 700 | mA |
| Peak Pulsing Current ^[2] | 1000 | 1000 | mA |
| Power Dissipation | 2450 | 3010 | mW |
| Reverse Voltage | 5 | 5 | V |
| LED Junction Temperature | 125 | 135 | °C |
| Operating Metal Slug Temperature Range at 350 mA | -40 to +115 | -40 to +120 | °C |
| Operating Metal Slug Temperature Range at 700 mA | -40 to +100 | -40 to +105 | °C |
| Storage Temperature Range | -40 to +120 | -40 to + 120 | °C |
| Soldering Temperature | Refer to Figure. 25 | | |

Note:

1. Derate linearly based on Figure 9 for AlInGaP and Figure 21 for InGaN.
2. Pulse condition duty factor = 10%, Frequency = 1 kHz.

Optical Characteristics at 350 mA (T_J = 25°C)

| Part Number | Color | Peak Wavelength, λ_{PEAK} (nm) | Dominant Wavelength, λ_D [1] (nm) | Viewing Angle, $2\theta_{1/2}$ [2] (°) | Luminous Efficiency (lm/W) |
|-----------------|------------|---|--|---|-------------------------------|
| | | Typ. | Typ. | Typ. | Typ. |
| ASMT-JR30-ARS01 | Red | 635 | 625 | 165 | 54 |
| ASMT-JH30-ARS01 | Red Orange | 625 | 615 | 165 | 54 |
| ASMT-JA30-ARS01 | Amber | 598 | 590 | 165 | 54 |
| ASMT-JG31-NST01 | Green | 519 | 525 | 165 | 57 |
| ASMT-JB31-NMP01 | Blue | 460 | 470 | 165 | 16 |
| ASMT-JL31-NPQ01 | Royal Blue | 450 | 455 | 165 | Not Applicable |

| Part Number | Color | Correlated Color Temperature, CCT (Kelvin) | | Viewing Angle, $2\theta_{1/2}$ [2] (°) | Luminous Efficiency (lm/W) |
|-----------------|---------------|---|-------|---|-------------------------------|
| | | Min. | Max. | Typ. | Typ. |
| ASMT-JW31-NTV01 | Cool White | 4500 | 10000 | 140 | 69 |
| ASMT-JW31-NUV01 | | 4500 | 10000 | 140 | 78 |
| ASMT-JN31-NTV01 | Neutral White | 3500 | 4500 | 140 | 69 |
| ASMT-JN31-NUV01 | | 3500 | 4500 | 140 | 78 |
| ASMT-JY31-NSU01 | Warm White | 2700 | 3500 | 140 | 57 |

Notes:

1. The dominant wavelength, λ_D , is derived from the CIE Chromaticity Diagram and represents the color of the device.
2. $\theta_{1/2}$ is the off-axis angle where the luminous intensity is 1/2 the peak intensity.

Electrical Characteristic at 350 mA (T_J = 25°C)

| Dice Type | Forward Voltage, V _F (Volts) at I _F = 350mA | | | Thermal Resistance, R θ_{j-ms} (°C/W) [1] |
|-----------|--|------|------|---|
| | Min. | Typ. | Max. | Typ. |
| AllInGaP | 1.9 | 2.4 | 3.1 | 9 |
| InGaN | 2.8 | 3.5 | 4.0 | 9 |

Note:

1. R θ_{j-ms} is Thermal Resistance from LED junction to metal slug.

Optical and Electrical Characteristic at 700 mA (T_J = 25°C)

| Part Number | Color | Luminous Flux (lm) / Radiometric Power (mW), ϕ_V | Forward Voltage, V _F (Volts) at I _F = 700mA | |
|-----------------|---------------|--|--|------|
| | | Typ. | Typ. | Max. |
| ASMT-JR30-ARS01 | Red | 80.0 | 2.8 | 3.5 |
| ASMT-JA30-ARS01 | Amber | 80.0 | 2.8 | 3.5 |
| ASMT-JH30-ARS01 | Red Orange | 80.0 | 2.8 | 3.5 |
| ASMT-JG31-NST01 | Green | 120.0 | 4.0 | 4.3 |
| ASMT-JB31-NMP01 | Blue | 33.0 | 4.0 | 4.3 |
| ASMT-JL31-NPQ01 | Royal Blue | 650 mW | 4.0 | 4.3 |
| ASMT-JW31-NTV01 | Cool White | 150.0 | 4.0 | 4.3 |
| ASMT-JW31-NUV01 | | 160.0 | 4.0 | 4.3 |
| ASMT-JN31-NTV01 | Neutral White | 150.0 | 4.0 | 4.3 |
| ASMT-JN31-NUV01 | | 160.0 | 4.0 | 4.3 |
| ASMT-JY31-NSU01 | Warm White | 120.0 | 4.0 | 4.3 |

AllnGaP

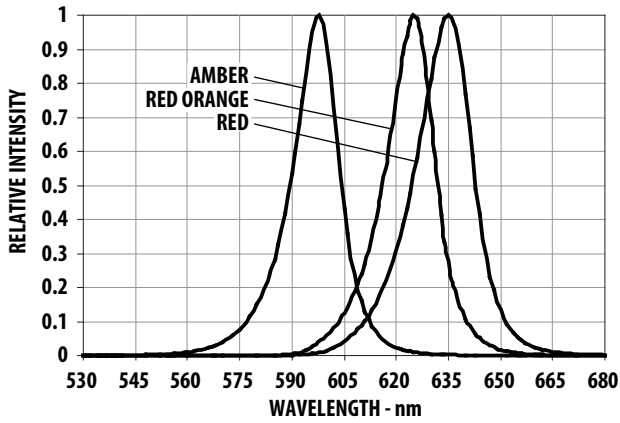

Figure 1. Relative Intensity vs. Wavelength for Red, Red Orange and Amber.

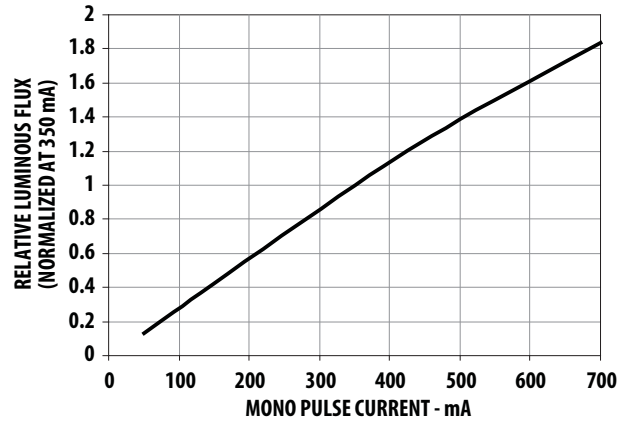

Figure 2. Relative Luminous Flux vs. Mono Pulse Current.

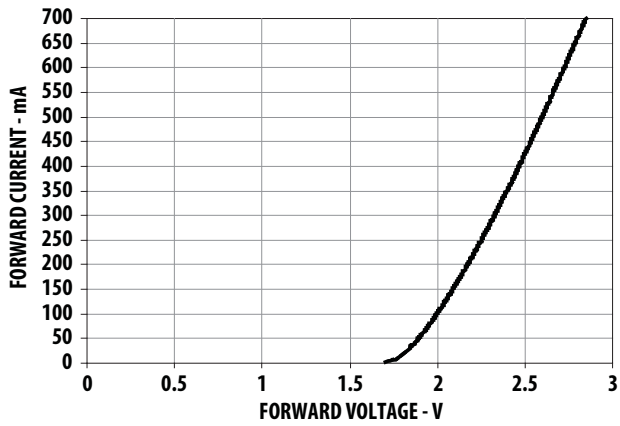

Figure 3. Forward Current vs. Forward Voltage.

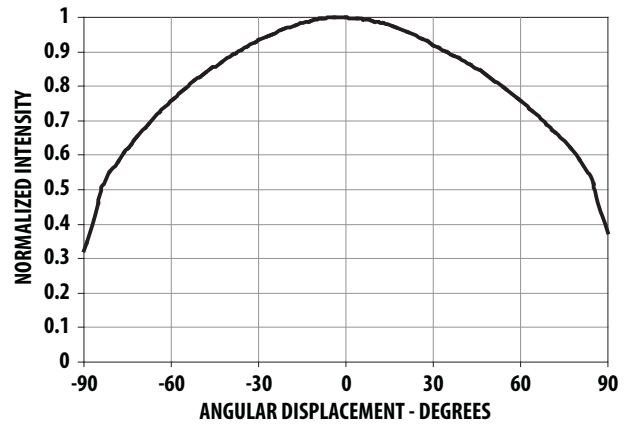

Figure 4. Radiation Pattern Red, Red Orange and Amber.

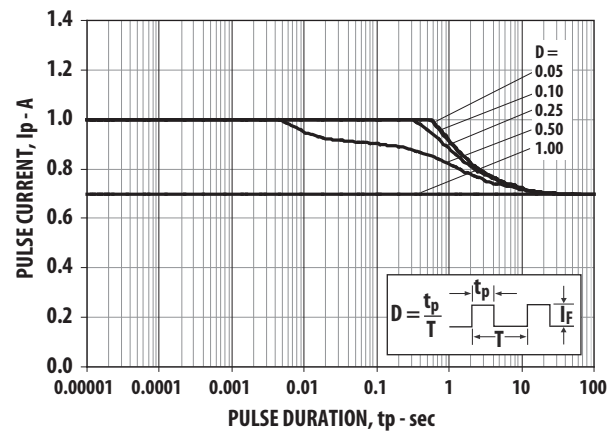

Figure 5. Maximum pulse current vs. ambient temperature. Derated based on $T_A = 25^\circ\text{C}$, $R\theta_{J-A} = 30^\circ\text{C/W}$.

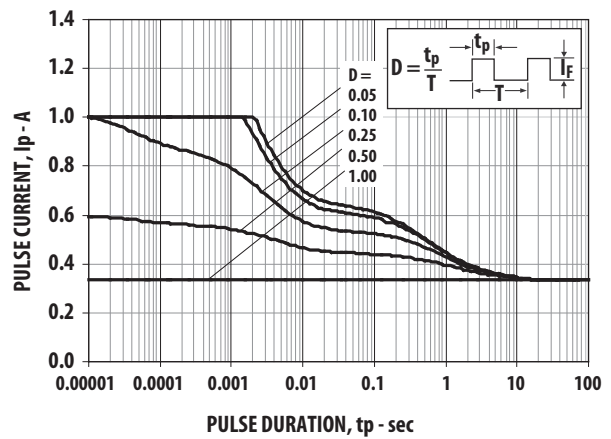

Figure 6. Maximum pulse current vs. ambient temperature. Derated based on $T_A = 85^\circ\text{C}$, $R\theta_{J-A} = 30^\circ\text{C/W}$.

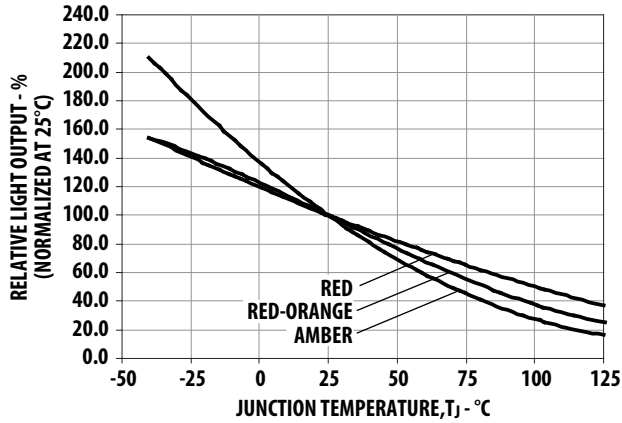

Figure 7. Relative Light Output vs. Junction Temperature.

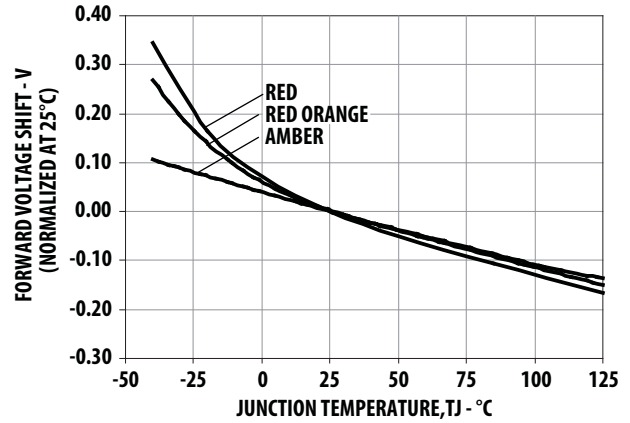

Figure 8. Forward Voltage Shift vs. Junction Temperature.

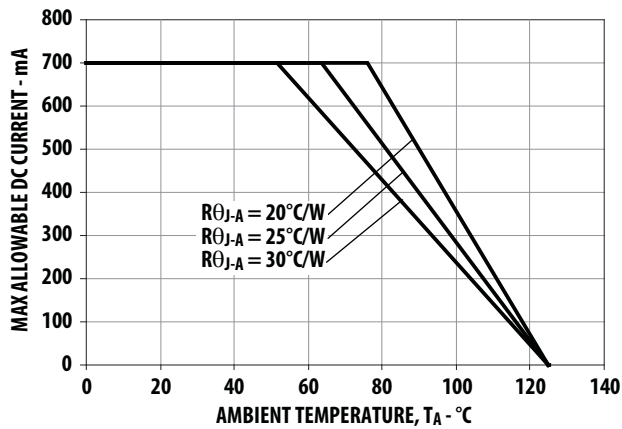

Figure 9. Maximum Forward Current vs. Ambient Temperature. Derated based on $T_{JMAX} = 125^{\circ}C$, $R_{\theta J-A} = 20^{\circ}C/W$, $25^{\circ}C/W$ and $30^{\circ}C/W$.

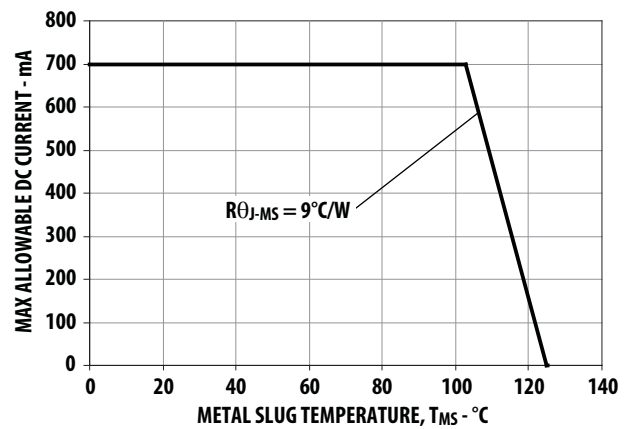

Figure 10. Maximum Forward Current vs. Ambient Temperature. Derated based on $T_{JMAX} = 125^{\circ}C$, $R_{\theta J-MS} = 9^{\circ}C/W$.

InGaN

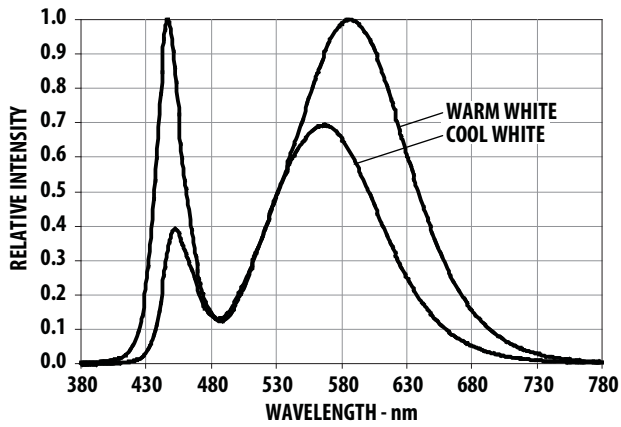

Figure 11. Relative Intensity vs. Wavelength for Cool and Warm White.

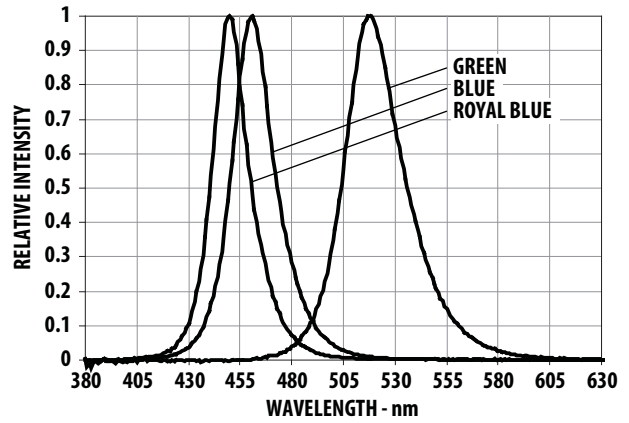

Figure 12. Relative Intensity vs. Wavelength for Blue and Green.

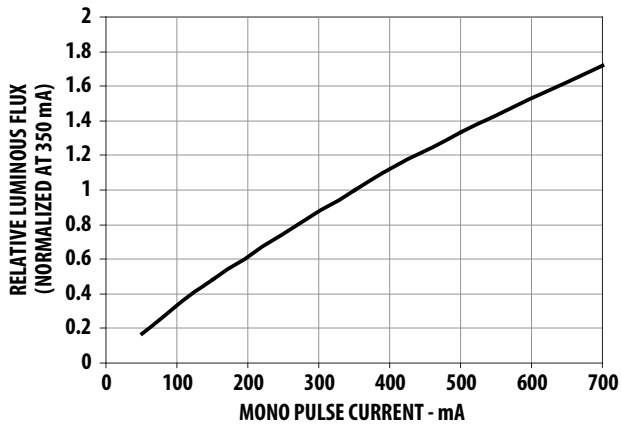

Figure 13. Relative Luminous Flux vs. Mono Pulse Current.

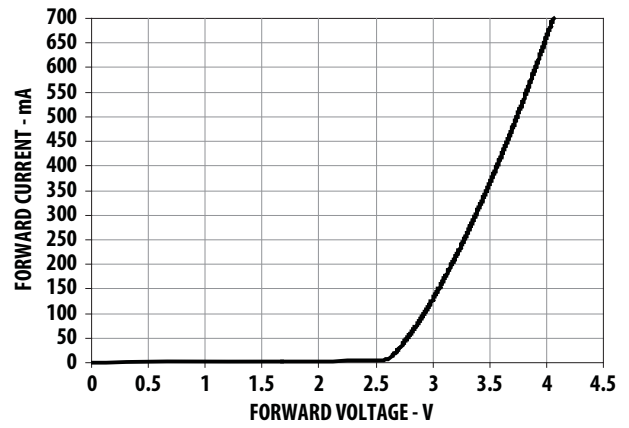

Figure 14. Forward Current vs. Forward Voltage.

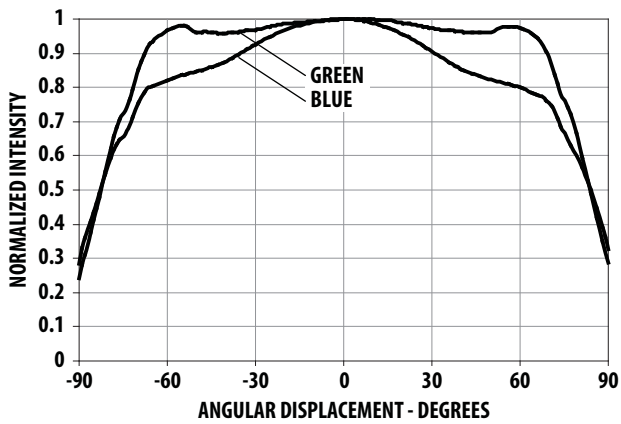

Figure 15. Radiation Pattern for Blue and Green.

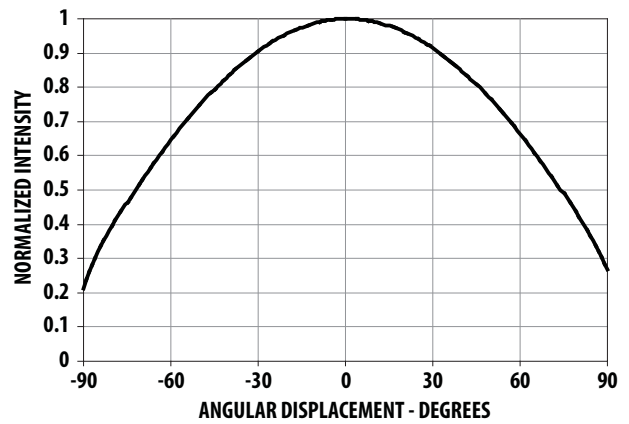

Figure 16. Radiation Pattern for Cool White and Warm White.

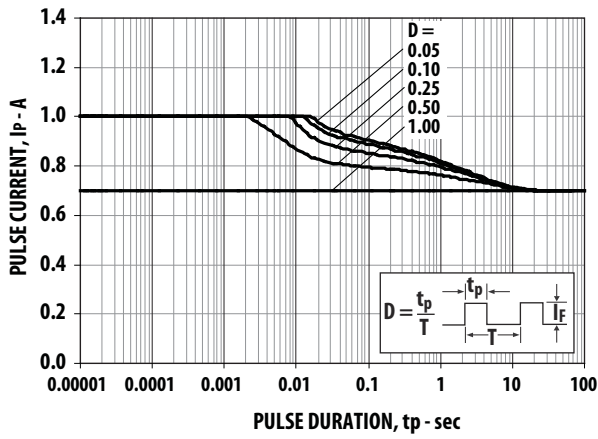

Figure 17. Maximum pulse current vs. ambient temperature. Derated based on $T_A = 25^\circ\text{C}$, $R_{\theta J-A} = 30^\circ\text{C/W}$.

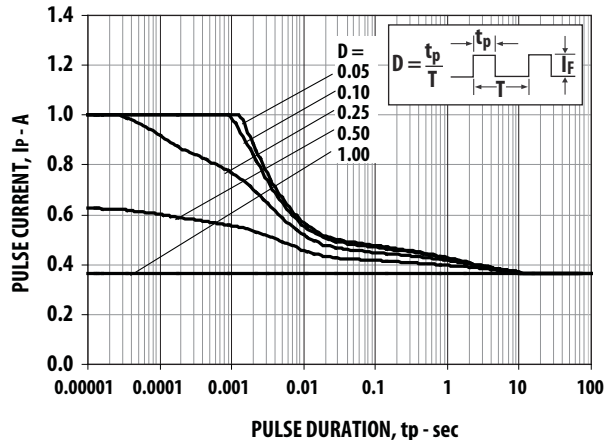

Figure 18. Maximum pulse current vs. ambient temperature. Derated based on $T_A = 85^\circ\text{C}$, $R_{\theta J-A} = 30^\circ\text{C/W}$.

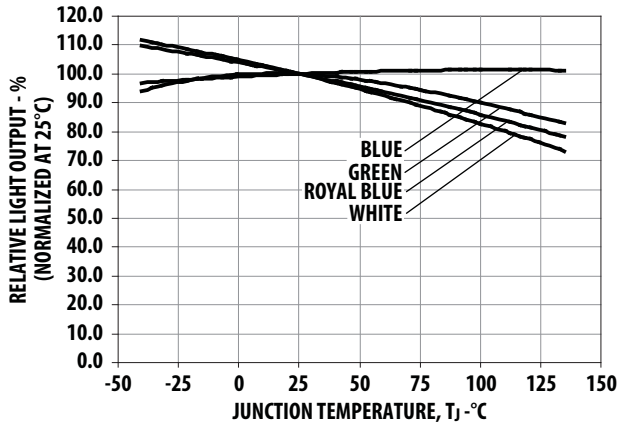

Figure 19. Relative Light Output vs. Junction Temperature.

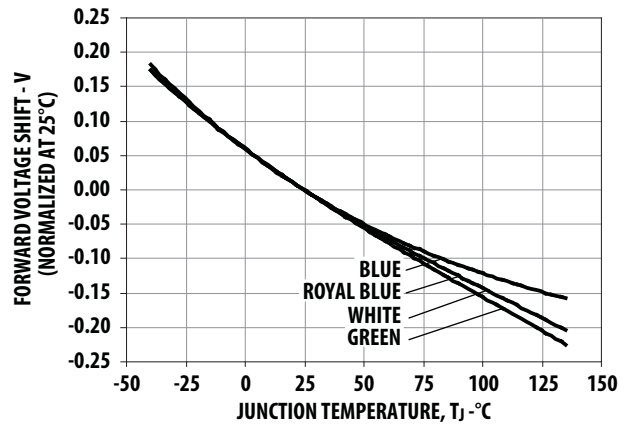

Figure 20. Forward Voltage Shift vs. Junction Temperature.

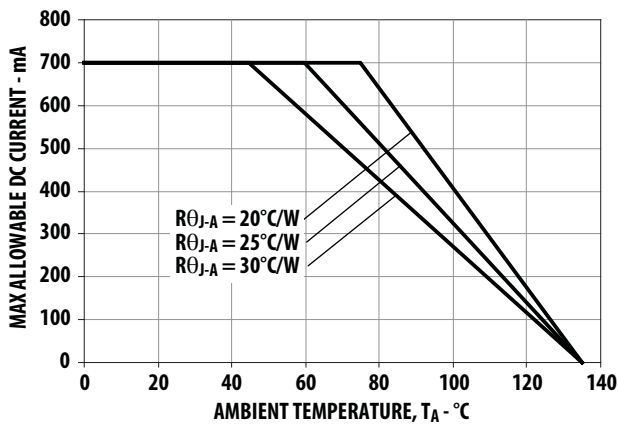

Figure 21. Maximum Forward Current vs. Ambient Temperature. Derated based on $T_{JMAX} = 135^\circ\text{C}$, $R_{\theta J-A} = 20^\circ\text{C/W}$, 25°C/W and 30°C/W .

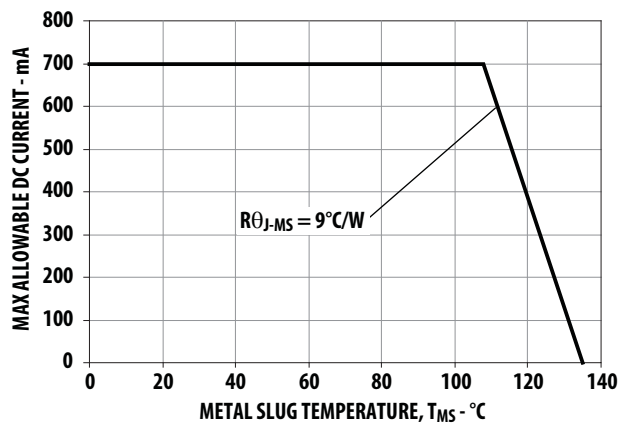

Figure 22. Maximum Forward Current vs. Metal Slug Temperature. Derated based on $T_{JMAX} = 135^\circ\text{C}$, $R_{\theta J-MS} = 9^\circ\text{C/W}$.

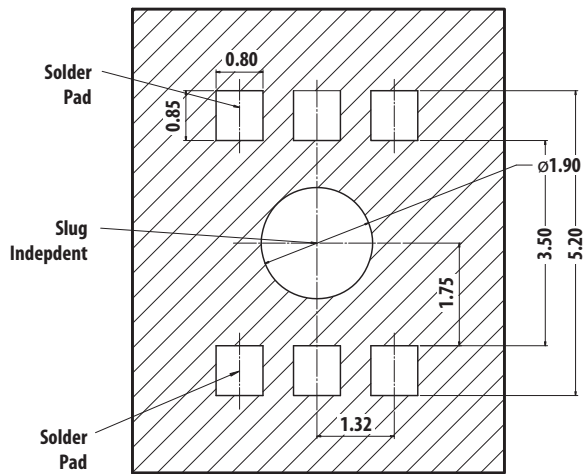

Figure 23. Recommended soldering land pattern.

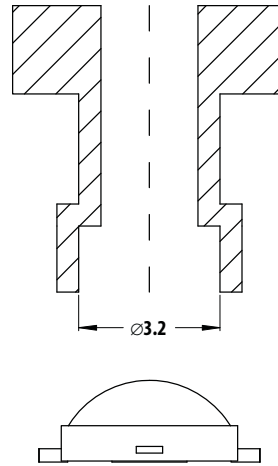

Figure 24. Recommended pick and place nozzle tip.
Inner diameter = 3.2 mm.

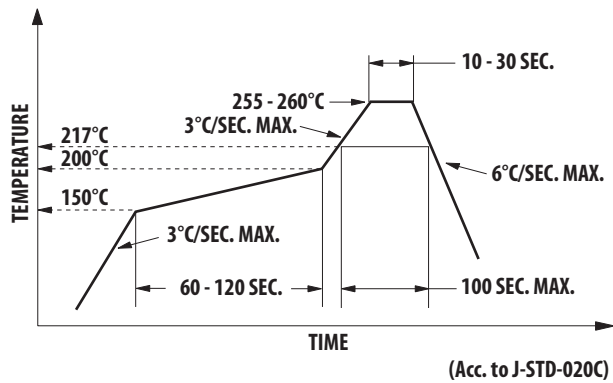

Figure 25. Recommended Reflow Soldering Profile.

Note: For detail information on reflow soldering of Avago surface mount LEDs, do refer to Avago Application Note AN 1060 Surface Mounting SMT LED Indicator Components.

Option Selection Details

ASMT-J x₁ 3 x₂ – x₃ x₄ x₅ x₆ x₇

x₄ – Minimum Flux Bin Selection

x₅ – Maximum Flux Bin Selection

x₆ – Color Bin Selection

x₇ – Packaging Option

Color Bin Selection (x₆)

Individual reel will contain parts from one full bin only.

Cool White

| O | Full Distribution |
|---|-----------------------|
| E | VM, UM, VN and UN |
| F | WM, VM, WN and VN |
| G | XM, WM, XN and WN |
| H | UN, VN, U0 and V0 |
| J | WN, VN, W0 and V0 |
| K | XN, WN, X0 and W0 |
| L | V0, U0, VP and UP |
| M | W0, V0, WP, VP and WQ |
| N | X0, W0, XP, WP and WQ |
| P | Y0 |
| Q | YA |

Neutral White

| O | Full Distribution |
|---|-------------------|
| E | SM, RM, S1 and R1 |
| F | TM, SM, TN and S1 |
| G | S1, R1, S0 and R0 |
| H | TN, S1, T0 and S0 |
| J | S0, R0, SA and RA |
| K | T0, S0, TP and SA |

Flux Bin Limit [x₄, x₅]

| Color | Bin ID | Luminous Flux (lm)/ Radiometric Power (mW) at 350 mA | |
|--------------|--------|--|-------|
| | | Min. | Max. |
| Blue | M | 13.9 | 18.1 |
| | N | 18.1 | 23.5 |
| | P | 23.5 | 30.6 |
| | Q | 30.6 | 39.8 |
| Other Colors | R | 39.8 | 51.7 |
| | S | 51.7 | 67.2 |
| | T | 67.2 | 87.4 |
| | U | 87.4 | 99.6 |
| | V | 99.6 | 113.6 |
| Royal Blue | M | 225.0 | 275.0 |
| | N | 275.0 | 355.0 |
| | P | 355.0 | 435.0 |
| | Q | 435.0 | 515.0 |

Tolerance for each bin limits is ±10%

Warm White

| O | Full Distribution |
|---|-------------------|
| E | NM, MM, N1 and M1 |
| F | PM, NM, P1 and N1 |
| G | QM, PM, Q1 and P1 |
| H | M1, N1, M0 and N0 |
| J | P1, N1, P0 and N0 |
| K | Q1, P1, Q0 and P0 |
| L | N0, M0, NA and MA |
| M | P0, N0, PA and NA |
| N | Q0, P0, QA and PA |

Other Colors

| O | Full Distribution |
|---|-------------------|
| Z | A and B |
| Y | B and C |
| W | C and D |
| V | D and E |
| Q | A, B and C |
| P | B, C and D |
| N | C, D and E |
| M | D, E and F |

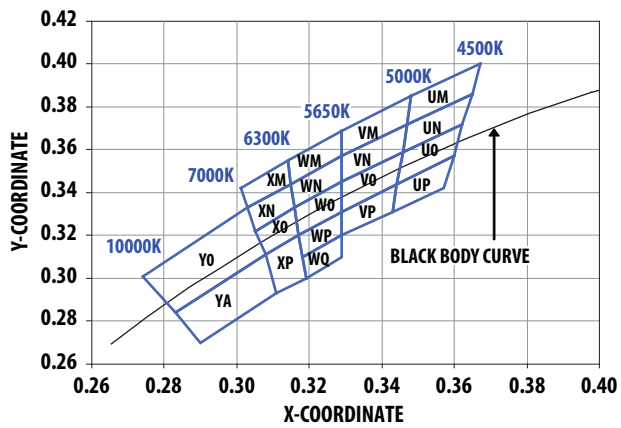

Figure 26. Color bin Structure for Cool White.

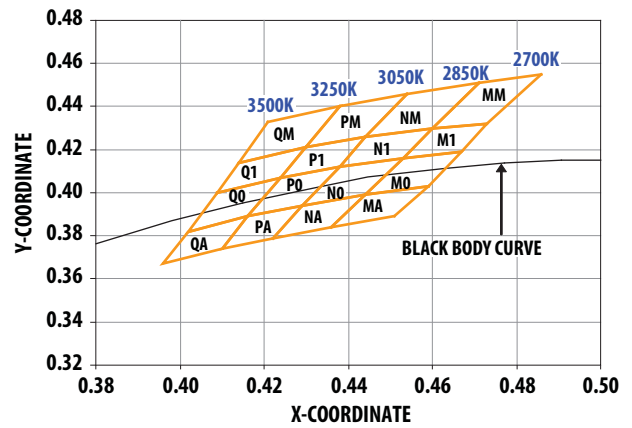

Figure 27. Color bin structure for Warm White.

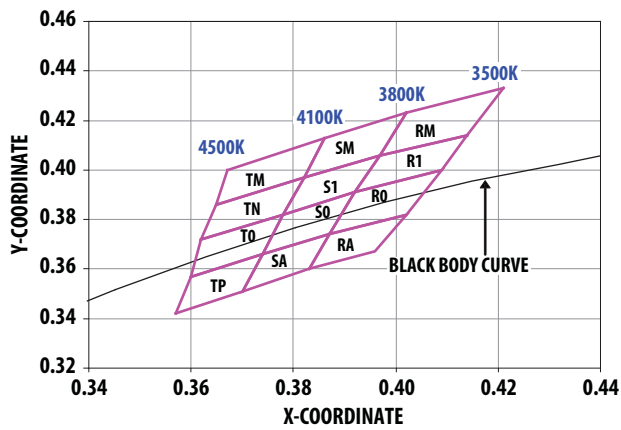

Figure 28. Color bin structure for Neutral White.

Color Bin Limits

| Cool White | Color Limits (Chromaticity Coordinates) | | | | |
|------------|---|-------|-------|-------|-------|
| | | x | y | | |
| Bin UM | x | 0.365 | 0.367 | 0.348 | 0.347 |
| | y | 0.386 | 0.400 | 0.385 | 0.372 |
| Bin UN | x | 0.365 | 0.362 | 0.346 | 0.347 |
| | y | 0.386 | 0.372 | 0.359 | 0.372 |
| Bin UO | x | 0.362 | 0.360 | 0.344 | 0.346 |
| | y | 0.372 | 0.357 | 0.344 | 0.359 |
| Bin UP | x | 0.360 | 0.357 | 0.343 | 0.344 |
| | y | 0.357 | 0.342 | 0.331 | 0.344 |
| Bin VM | x | 0.329 | 0.329 | 0.348 | 0.347 |
| | y | 0.357 | 0.369 | 0.385 | 0.372 |
| Bin VN | x | 0.329 | 0.329 | 0.347 | 0.346 |
| | y | 0.345 | 0.357 | 0.372 | 0.359 |
| Bin VO | x | 0.329 | 0.329 | 0.346 | 0.344 |
| | y | 0.331 | 0.345 | 0.359 | 0.344 |
| Bin VP | x | 0.329 | 0.344 | 0.343 | 0.329 |
| | y | 0.331 | 0.344 | 0.331 | 0.320 |
| Bin WM | x | 0.329 | 0.329 | 0.315 | 0.314 |
| | y | 0.369 | 0.357 | 0.344 | 0.355 |
| Bin WN | x | 0.329 | 0.316 | 0.315 | 0.329 |
| | y | 0.345 | 0.333 | 0.344 | 0.357 |
| Bin W0 | x | 0.329 | 0.329 | 0.317 | 0.316 |
| | y | 0.345 | 0.331 | 0.320 | 0.333 |
| Bin WP | x | 0.329 | 0.329 | 0.318 | 0.317 |
| | y | 0.331 | 0.320 | 0.310 | 0.320 |
| Bin WQ | x | 0.329 | 0.329 | 0.319 | 0.318 |
| | y | 0.320 | 0.310 | 0.300 | 0.310 |
| Bin XM | x | 0.301 | 0.314 | 0.315 | 0.303 |
| | y | 0.342 | 0.355 | 0.344 | 0.333 |
| Bin XN | x | 0.305 | 0.303 | 0.315 | 0.316 |
| | y | 0.322 | 0.333 | 0.344 | 0.333 |
| Bin XO | x | 0.308 | 0.305 | 0.316 | 0.317 |
| | y | 0.311 | 0.322 | 0.333 | 0.320 |
| Bin XP | x | 0.308 | 0.317 | 0.319 | 0.311 |
| | y | 0.311 | 0.320 | 0.300 | 0.293 |
| Bin YO | x | 0.308 | 0.283 | 0.274 | 0.303 |
| | y | 0.311 | 0.284 | 0.301 | 0.333 |
| Bin YA | x | 0.308 | 0.311 | 0.290 | 0.283 |
| | y | 0.311 | 0.293 | 0.270 | 0.284 |

Tolerance: ±0.01

| Warm White | Color Limits (Chromaticity Coordinates) | | | | |
|------------|---|-------|-------|-------|-------|
| | | x | y | | |
| Bin MM | x | 0.471 | 0.460 | 0.473 | 0.486 |
| | y | 0.451 | 0.430 | 0.432 | 0.455 |
| Bin M1 | x | 0.460 | 0.453 | 0.467 | 0.473 |
| | y | 0.430 | 0.416 | 0.419 | 0.432 |
| Bin M0 | x | 0.453 | 0.444 | 0.459 | 0.467 |
| | y | 0.416 | 0.399 | 0.403 | 0.419 |
| Bin MA | x | 0.459 | 0.444 | 0.436 | 0.451 |
| | y | 0.403 | 0.399 | 0.384 | 0.389 |
| Bin NM | x | 0.454 | 0.444 | 0.460 | 0.453 |
| | y | 0.446 | 0.426 | 0.430 | 0.416 |
| Bin N1 | x | 0.444 | 0.438 | 0.453 | 0.436 |
| | y | 0.426 | 0.412 | 0.416 | 0.384 |
| Bin N0 | x | 0.438 | 0.429 | 0.444 | 0.460 |
| | y | 0.412 | 0.394 | 0.399 | 0.430 |
| Bin NA | x | 0.444 | 0.429 | 0.422 | 0.471 |
| | y | 0.399 | 0.394 | 0.379 | 0.451 |
| Bin PM | x | 0.438 | 0.430 | 0.444 | 0.454 |
| | y | 0.440 | 0.421 | 0.426 | 0.446 |
| Bin P1 | x | 0.430 | 0.424 | 0.438 | 0.444 |
| | y | 0.421 | 0.407 | 0.412 | 0.426 |
| Bin P0 | x | 0.424 | 0.416 | 0.429 | 0.438 |
| | y | 0.407 | 0.389 | 0.394 | 0.412 |
| Bin PA | x | 0.429 | 0.416 | 0.410 | 0.422 |
| | y | 0.394 | 0.389 | 0.374 | 0.379 |
| Bin QM | x | 0.421 | 0.414 | 0.430 | 0.438 |
| | y | 0.433 | 0.414 | 0.421 | 0.440 |
| Bin Q1 | x | 0.414 | 0.409 | 0.424 | 0.430 |
| | y | 0.414 | 0.400 | 0.407 | 0.421 |
| Bin Q0 | x | 0.409 | 0.402 | 0.416 | 0.424 |
| | y | 0.400 | 0.382 | 0.389 | 0.407 |
| Bin QA | x | 0.416 | 0.402 | 0.396 | 0.410 |
| | y | 0.389 | 0.382 | 0.367 | 0.374 |

Tolerance: ±0.01

| Neutral White | Color Limits (Chromaticity Coordinates) | | | | |
|---------------|---|-------|-------|-------|-------|
| | | x | y | z | u |
| Bin RM | x | 0.421 | 0.414 | 0.397 | 0.402 |
| | y | 0.433 | 0.414 | 0.406 | 0.423 |
| Bin R1 | x | 0.414 | 0.409 | 0.392 | 0.397 |
| | y | 0.414 | 0.400 | 0.391 | 0.406 |
| Bin R0 | x | 0.392 | 0.387 | 0.402 | 0.409 |
| | y | 0.391 | 0.374 | 0.382 | 0.400 |
| Bin RA | x | 0.387 | 0.383 | 0.396 | 0.402 |
| | y | 0.374 | 0.360 | 0.367 | 0.382 |
| Bin SM | x | 0.402 | 0.397 | 0.382 | 0.386 |
| | y | 0.423 | 0.406 | 0.397 | 0.413 |
| Bin S1 | x | 0.397 | 0.392 | 0.378 | 0.382 |
| | y | 0.406 | 0.391 | 0.382 | 0.397 |
| Bin S0 | x | 0.392 | 0.387 | 0.374 | 0.378 |
| | y | 0.391 | 0.374 | 0.366 | 0.382 |
| Bin SA | x | 0.387 | 0.383 | 0.370 | 0.374 |
| | y | 0.374 | 0.360 | 0.351 | 0.366 |
| Bin TM | x | 0.386 | 0.382 | 0.365 | 0.367 |
| | y | 0.413 | 0.397 | 0.386 | 0.400 |
| Bin TN | x | 0.382 | 0.378 | 0.362 | 0.365 |
| | y | 0.397 | 0.382 | 0.372 | 0.386 |
| Bin T0 | x | 0.378 | 0.374 | 0.360 | 0.362 |
| | y | 0.382 | 0.366 | 0.357 | 0.372 |
| Bin TP | x | 0.374 | 0.370 | 0.357 | 0.360 |
| | y | 0.366 | 0.351 | 0.342 | 0.357 |

Tolerance: ±0.01

Packaging Option [x₇]

| Selection | Option |
|-----------|---------------|
| 1 | Tape and Reel |

| Color | Bin ID | Dominant Wavelength (nm) at 350 mA | |
|------------|--------|------------------------------------|-------|
| | | Min. | Max. |
| Red | – | 620.0 | 635.0 |
| Red Orange | – | 610.0 | 620.0 |
| Amber | B | 587.0 | 589.5 |
| | C | 589.5 | 592.0 |
| | D | 592.0 | 594.5 |
| | E | 594.5 | 597.0 |
| | – | – | – |
| Blue | A | 460.0 | 465.0 |
| | B | 465.0 | 470.0 |
| | C | 470.0 | 475.0 |
| | D | 475.0 | 480.0 |
| Green | A | 515.0 | 520.0 |
| | B | 520.0 | 525.0 |
| | C | 525.0 | 530.0 |
| | D | 530.0 | 535.0 |

Tolerance: ±1 nm

| Color | Bin ID | Peak Wavelength (nm) at 350 mA | |
|------------|--------|--------------------------------|-------|
| | | Min. | Max. |
| Royal Blue | C | 440.0 | 445.0 |
| | D | 445.0 | 450.0 |
| | E | 450.0 | 455.0 |
| | F | 455.0 | 460.0 |

Tolerance: ±2 nm

Example

ASMT-JG31-NST01

ASMT-JG31-Nxxxx – Green, InGaN, Electrically isolated Heat Sink

- X₄ = S – Minimum Flux Bin S
- X₅ = T – Maximum Flux Bin T
- X₆ = 0 – Full Distribution
- X₇ = 1 – Tape and Reel Option

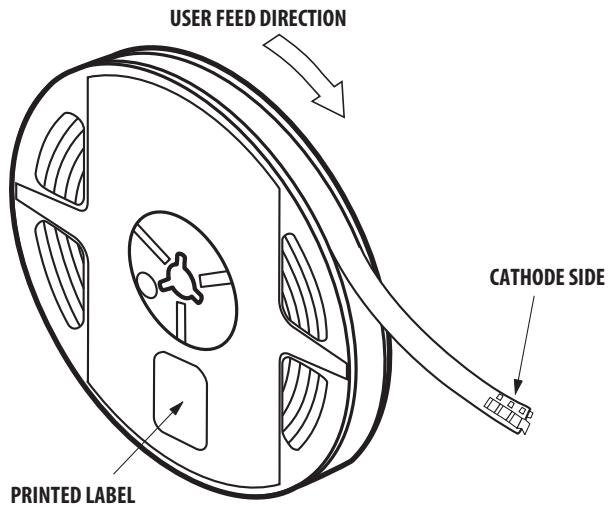

Figure 31. Reeling Orientation.

DISCLAIMER: Avago's products and software are not specifically designed, manufactured or authorized for sale as parts, components or assemblies for the planning, construction, maintenance or direct operation of a nuclear facility or for use in medical devices or applications. Customer is solely responsible, and waives all rights to make claims against avago or its suppliers, for all loss, damage, expense or liability in connection with such use.

For product information and a complete list of distributors, please go to our web site: www.avagotech.com

Avago, Avago Technologies, and the A logo are trademarks of Avago Technologies in the United States and other countries. Data subject to change. Copyright © 2005-2009 Avago Technologies. All rights reserved.
AV02-1941EN - November 16, 2009

Avago
TECHNOLOGIES