



A Low-Cost Surface Mount PIN Diode π Attenuator

Application Note 1048

Introduction

Analog attenuators find wide application in RF and microwave networks. Realized as either GaAs MMICs or PIN diode networks, these circuits are used to set the power level of an RF signal from a voltage control. In commercial applications, such as cellular telephone, PCN (Personal Communication Networks), wireless LANs (Local Area Networks) and portable radios, cost is a significant consideration in the design of such attenuators. This paper describes a low cost wideband PIN diode π

(Pi) attenuator which utilizes plastic packaged surface mounted devices.

Background

The basic π fixed attenuator is shown, along with its design equations, in Figure 1. Shunt resistors R_1 and the series resistor R_3 are set to achieve some desired value of attenuation $A = 20 \log(K)$ while simultaneously providing an input and output impedance which matches the characteristic impedance of the system.

When operated at frequencies well above its cutoff frequency f_c (see

Appendix A), the PIN diode can be used as a current controlled variable resistor. Three diodes can be used to replace the fixed resistors of the π circuit to create a variable attenuator, and such circuits have been described in the literature. For example, a three diode π attenuator¹ is shown in Figure 2 which provides good performance over the frequency range of 10 MHz to over 500 MHz. However, the use of three diodes as the three variable resistors in a π attenuator leads to asymmetry in the network, which results in a rather complicated bias network.

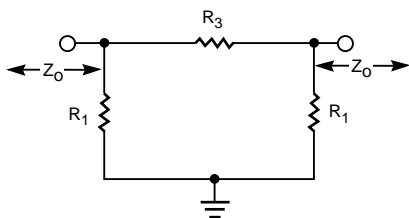

$$R_1 = Z_0 \left[\frac{K+1}{K-1} \right]$$

$$R_3 = \frac{Z_0}{2} \left[K - \frac{1}{K} \right]$$

WHERE K IS THE INPUT TO OUTPUT VOLTAGE RATIO AND Z_0 IS THE IMPEDANCE OF THE SOURCE AND LOAD

Figure 1. Basic π Attenuator.

¹ "The PIN Diode," from the Hewlett-Packard RF and Microwave Applications Seminar, 1973.

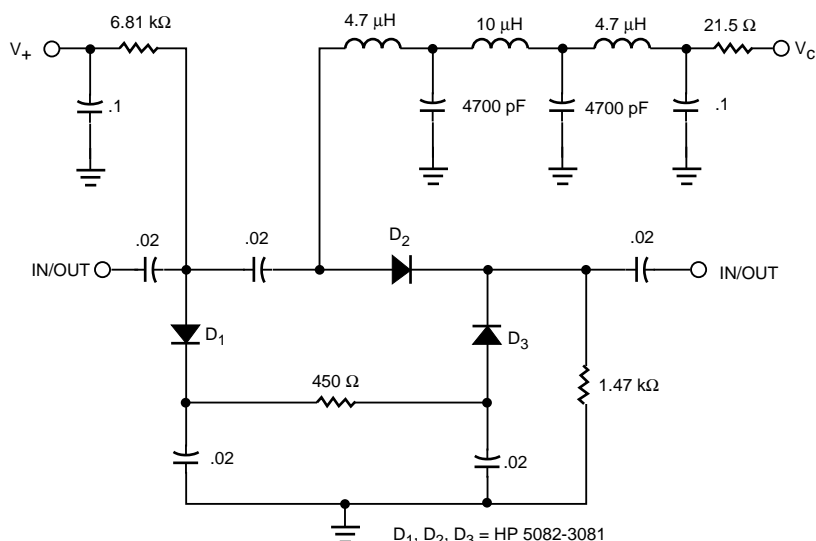

Figure 2. 3 Diode Attenuator.

$D_1, D_2, D_3 = \text{HP 5082-3081}$

Four Diode π Attenuator

If resistor R_3 is replaced by two diodes, as shown in Figure 3, several benefits result. First, since the maximum isolation of the network is set by the capacitive reactance of the series diode(s), the use of two diodes in place of one will increase the maximum attenuation or double the upper frequency limit for a given value of attenuation. Second, the twin diodes which occupy the position of the series resistor are physically set up 180° out of phase, resulting in the cancellation of even order distortion products². Third, the resulting attenuator network is symmetrical and the bias network is substantially simplified. V_+ is a fixed voltage, and V_C is the variable voltage

which controls the attenuation of the network. The only drawback to using two series diodes in place of one is the slight increase in insertion loss, amounting to less than 0.5 dB additional loss. R_1 and R_2 serve as bias returns for series diodes D_2 and D_3 ; they must be set high enough to minimize insertion loss; however, if they are set too high, an excessively large control voltage V_C will result. If the designer does not require very large bandwidth, some savings in insertion loss can be achieved by adding chokes between R_1 and R_2 and the RF line, using these inductors to decouple the resistors from the RF portion of the network. R_3 and R_4 are chosen to match the characteristics of the specific PIN diodes used; properly selected, they will

provide for the correct split of bias current between series and shunt diodes required to maintain good impedance match over the entire dynamic range of attenuation. While analysis can be used to determine the values of R_1 through R_4 , it is much quicker and easier to select them empirically.

The Agilent HSMP-3810 series of surface mount PIN diodes features good distortion performance, low cutoff frequency and low price. To save cost and space on the board, two HSMP-3814 common-cathode pairs were chosen over four individual HSMP-3810 diodes. Having chosen these diodes, and selecting $V_+ = 5V$ and $0 \leq V_C \leq 15V$, the values of R_1 through R_4 were empirically determined. Values for all components used in the tested circuit are shown in Figure 3.

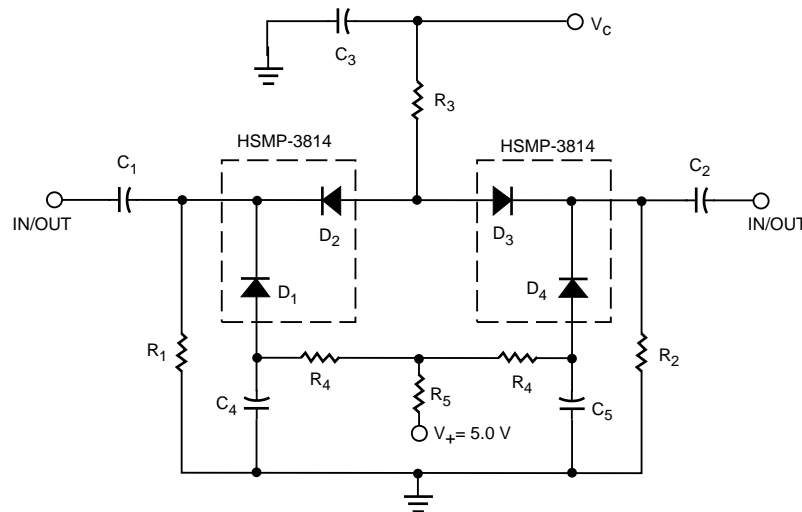

COMPONENT	VALUE	MFG./PART NUMBER
R_1, R_2	560 Ω	KYOCERA CR21-561JB1
R_3	330 Ω	KYOCERA CR21-331JB1
R_4	1640 Ω	KYOCERA CR21-162JB1
R_5	680 Ω	KYOCERA CR21-6B1JB1
C_1-C_5	47000 pF	KYOCERA 0805Z473M2P03
D_1-D_4	-	AGILENT HSMP-3814

Figure 3. Wideband 4 Diode π Attenuator.

The attenuator was laid out on a 2 inch square of 0.032" thick HT-2 PC board, as shown in Figure 5. This material, a high performance alternative to conventional FR4, is described in detail in Appendix B. Using chip resistors and capacitors, the entire attenuator occupies a 0.5 in² space as shown in Figure 5.

Test Results

In Figure 6, the measured attenuation vs. frequency is given for several values of control voltage. Good performance is obtained over the frequency range of 300 KHz to 3 GHz. Figure 7 contains the plot of return loss vs. frequency at the maximum and minimum values of V_C . For all other values, the return

²Raymond Waugh, "A Low Distortion PIN Diode Switch Using Surface Mount Devices," Proceedings of RF EXPO WEST, pp 455 - 461, Feb. 5 - 7, 1991.

loss was higher; the data for $V_C = 0$ represents the worst case. In Figure 8, a plot is given for attenuation vs. control voltage at a number of frequencies. Finally, the intermodulation distortion performance of the attenuator is plotted in Figure 9. The data are given as

intercept points; for a detailed explanation of intercept points, see Appendix C.

Conclusion

As can be seen from these data, the four diode π attenuator provides very good match and very

flat attenuation over an extremely wide band. Using surface mount devices, it has the additional benefit of being low cost. Realized as a thin-film or thick-film hybrid circuit with chip PIN diodes, it would fit within a TO-8 can.

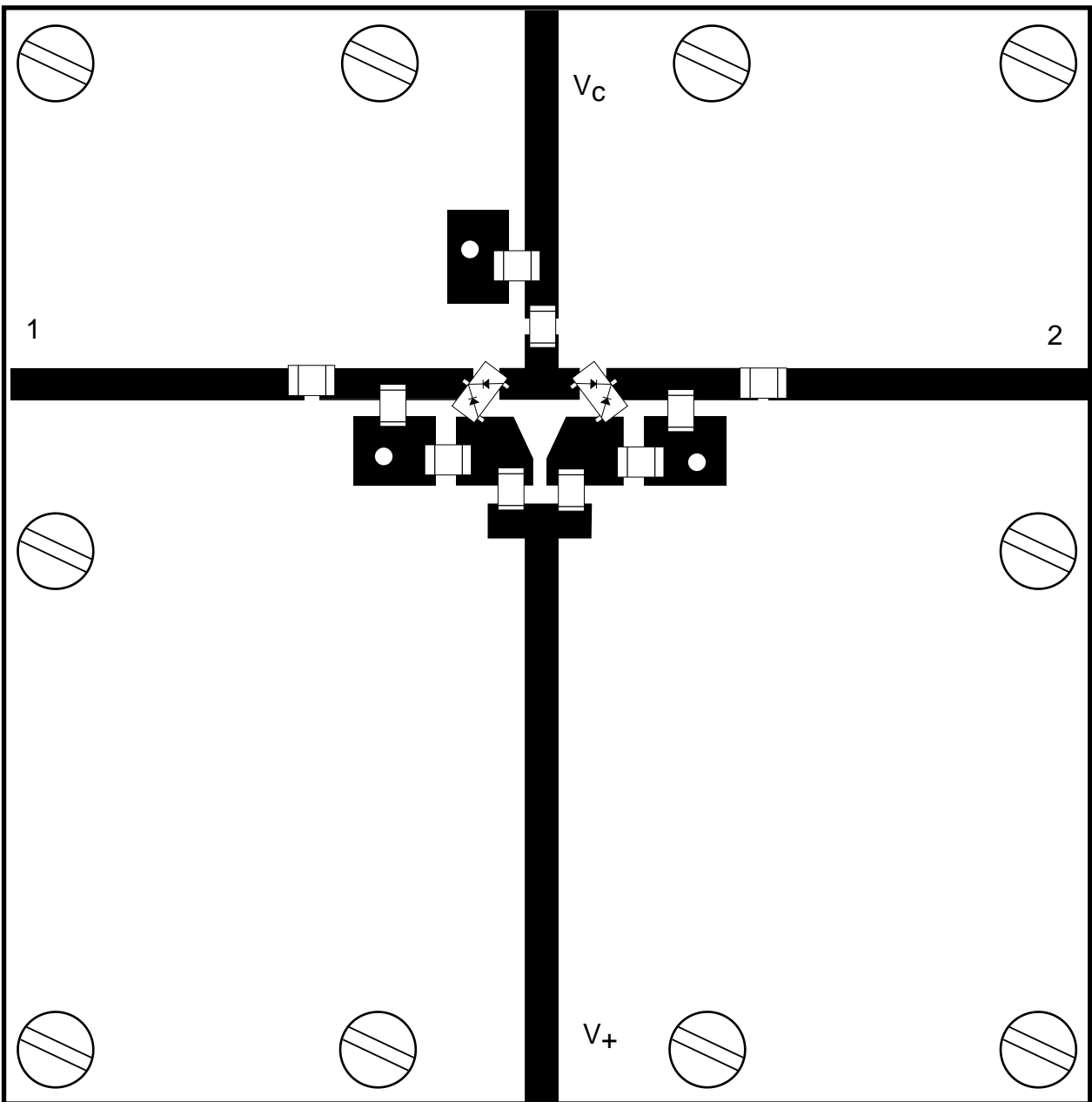

Figure 4. Circuit Board Layout.

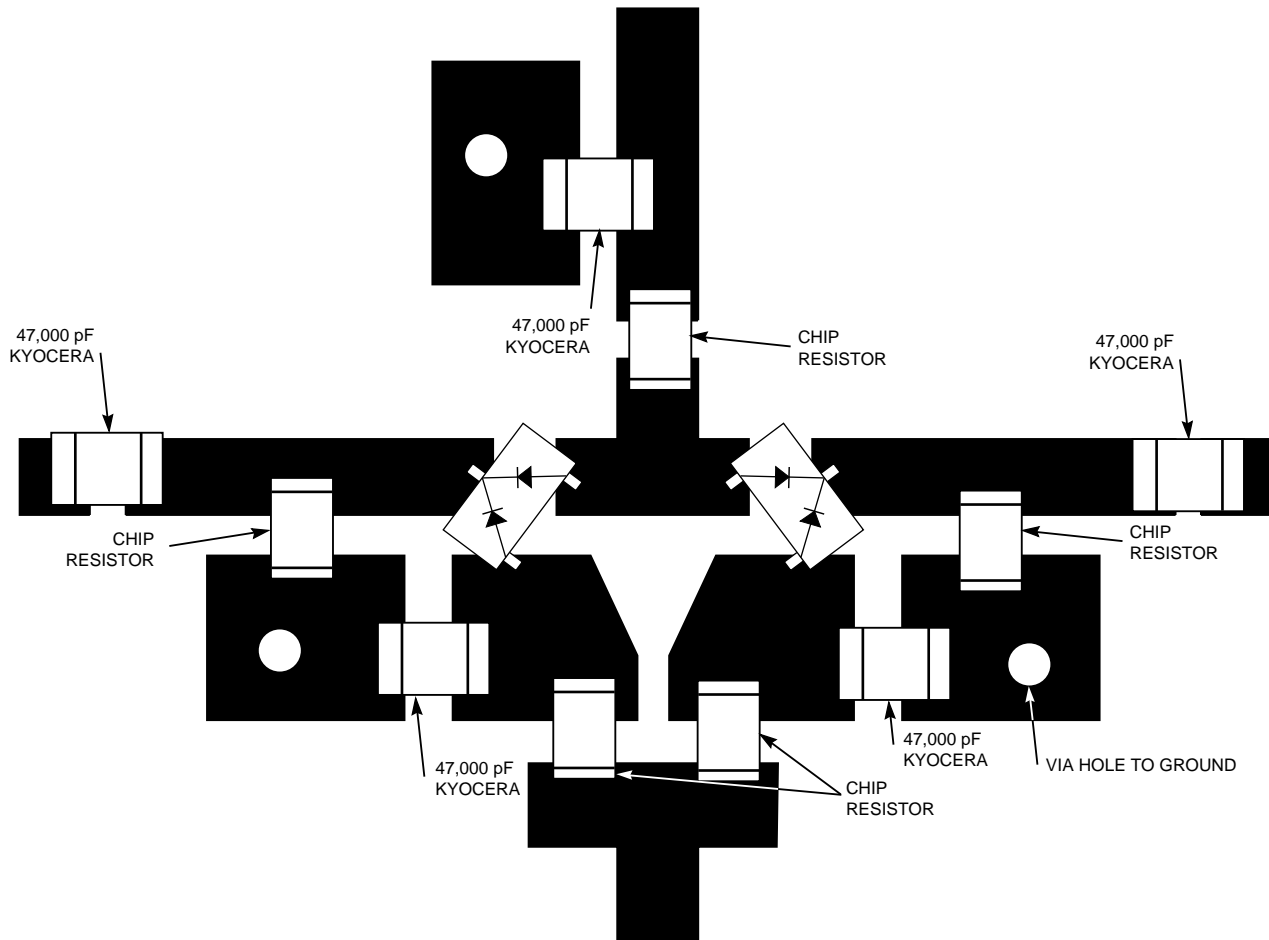

Figure 5. Detail of Circuit Layout.

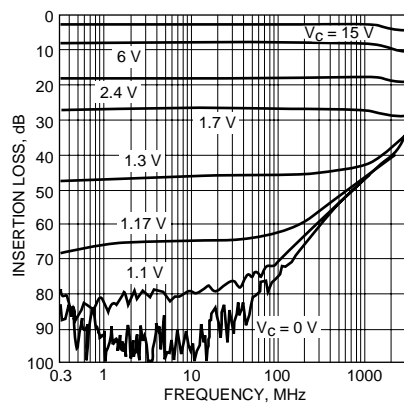

Figure 6. Attenuation vs. Frequency.

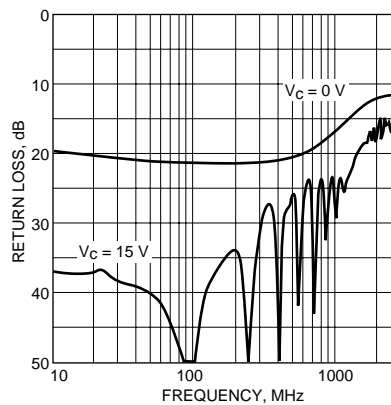

Figure 7. Return Loss vs. Frequency.

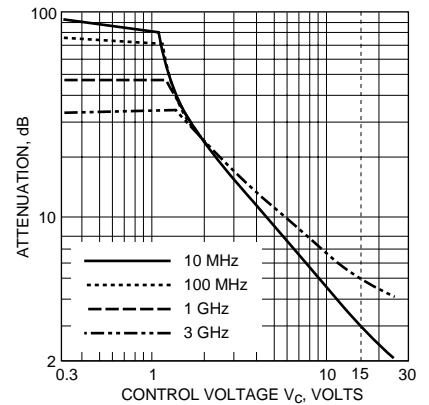

Figure 8. Attenuation vs. Control Voltage.

Appendix A - PIN Diode Cutoff Frequency

The PIN diode is generally considered to be a current controlled RF resistor. However, this model is accurate only at frequencies well above the diode's cutoff frequency, $f_c = 1 / 2\pi\tau$, where τ is the minority carrier lifetime of the device. At frequencies 10 times f_c , a PIN diode can accurately be modelled as a current controlled resistance in parallel with a small (and constant) junction capacitance (neglecting package parasitics). At frequencies under $0.1 f_c$, the PIN diode behaves as an ordinary PN junction diode. For $0.1 f_c \leq$ frequencies $\leq 10 f_c$, the characteristics of the PIN diode become very complex; it will generally behave as a frequency-dependent resistance shunted by a very large frequency and current dependent inductance or capacitance. Additionally, distortion performance will usually be very poor when operating in this frequency range. For the HSMP-3810 series of diodes, $\tau \cong 1500$ nsec, resulting in a cutoff frequency of 100 kHz. This diode should therefore provide frequency-independent values of pure resistance at frequencies above 1 MHz. However, because this diode has been optimized for wideband attenuator applications, its characteristics remain generally well behaved down to frequencies below f_c , as can be seen from the 300 kHz measured data shown in Figure 6.

Appendix B - Board Material

Several printed circuit board materials are in common use for RF circuits such as this one. Two of the most popular are FR4 and fiberglass reinforced PTFE (Teflon®). The former provides

good mechanical stability and durability at low cost. However, it suffers from high losses and a dielectric constant which is poorly controlled and strongly frequency-dependent. The latter exhibits very good RF properties, but is expensive, suffers from poor mechanical stability, and cannot survive certain SMT (Surface Mount Technology) processing steps. Agilent's new HT-2 board material provides durability and high temperature performance which are actually superior to FR4 with a controlled dielectric constant ($\epsilon_r \cong 4.3$) and a loss tangent which is half that of FR4. These properties make it ideal for microstrip circuits operating beyond 6 GHz.

At the time of this printing, HT-2 is available through Dan Schutte of International Circuits, 1319 South Arkle Street, Visalia, CA.

Appendix C - The Intercept Point

Of the several types of distortion products, one of the most troublesome is intermodulation distortion. Unlike harmonic distortion, this is a multi-tone product resulting when two or more signals of equal (or unequal) amplitude mix in a non-linear device such as a PIN diode. The frequency of the resulting unwanted signal is related to those of the original input voltages. In certain industries, the number of input signals may exceed 10, and both test and analysis become very complex. To keep matters as simple as possible, many semiconductor manufacturers make two-tone measurements using two voltages which are equal in amplitude and closely spaced in frequency. Given two such input signals at frequencies f_1 and f_2 , one can com-

pute several significant intermodulation distortion products from the equation

$$Kf_1 \pm Mf_2$$

where $K, M = 1, 2, 3, \dots$

The order of the distortion product is given by the sum $N = K + M$.

Of the infinite number of distortion products described by this equation, one is of special significance. The third order products given in Figure 1 are important because they exist on either side of the original signals f_1 and f_2 and cannot be removed by filtering.

The behavior of all types of distortion products is shown on Figure 10. As can be seen, an increase of 1 dBm in the applied signal's power will result in a 2 dBm increase in the second order products and a 3 dBm increase in the third order products. Since the level of measured distortion is dependent upon the level of the input signal, it is convenient to specify

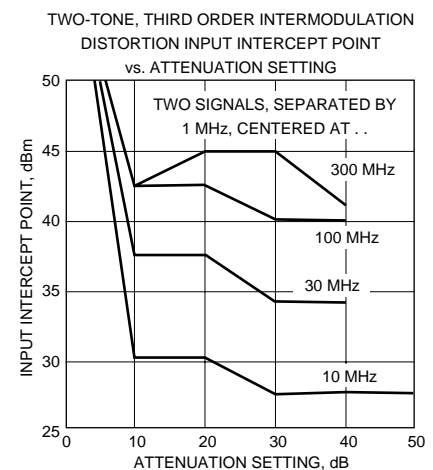

Figure 9. Measured Distortion Performance.

distortion in terms of a fictitious constant, the intercept point. This is the point at which the extrapolated fundamental signal and the extrapolated distortion product meet. In making distortion measurements, it is most convenient to measure the input power of the signal(s) applied to the DUT (De-

vice Under Test) and the output power of the distortion products. For this reason, and because the input intercept point varies less with attenuation, the input intercept point is the one most often calculated and specified. Using it, we can neatly specify the performance for a given type of distor-

tion using a single number. The equation for input intercept point is

$$IP_{in} = \frac{N(P_{in} - \alpha) - P_{dist}}{N - 1} + \alpha, \text{ in dBm}$$

where N = order of distortion product, and all power levels are specified in dBm.

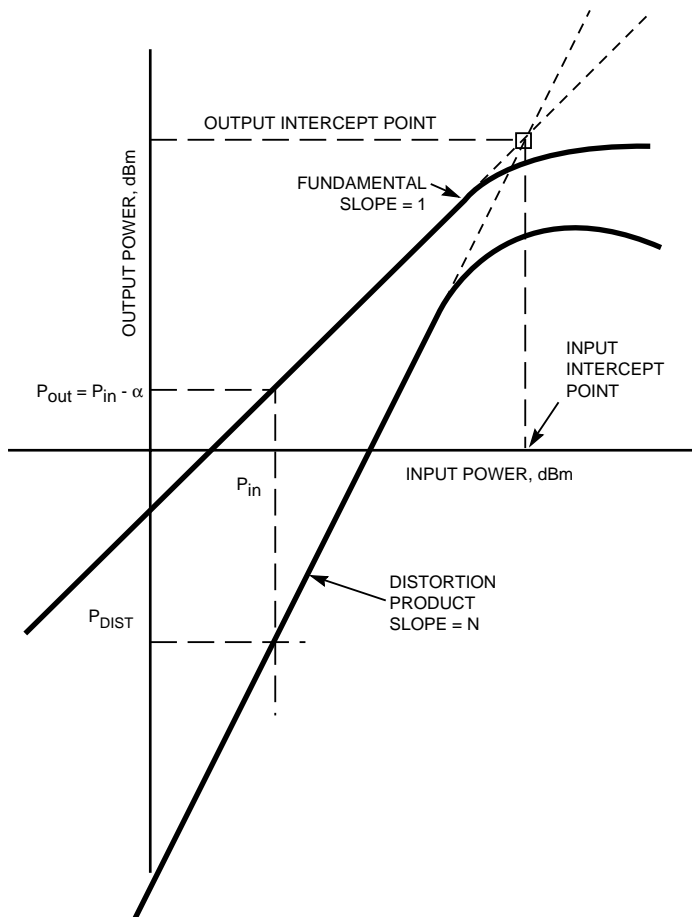

Figure 10. Behavior of Distortion Products.

Addendum (2/00)

Introduction

This addendum contains background material to the design process used to develop a variable attenuator. It describes a low cost wideband PIN diode π (Pi) attenuator which may be realised in both the SOT-23 and the SOT-323 plastic packaged surface mount devices, see Figure 2. The paper also introduces a new evaluation board, which has been designed to accommodate both package types that has an active area of only 20 x 15 mm (0.78 x 0.59 inches).

Description

The HSMP-386X series is a general purpose PIN diode designed for low current attenuators and low cost switches. For detailed design information covering the use of the HSMP-386X series refer to the data sheets. (Request Agilent publications 5967-6070E for SOT-323 devices and 5966-0940E for SOT-23 devices).

Test Results

The test results for the HSMP-3814 series of PIN diodes are available in Application Note 1048 (Request Agilent publication 5966-0449E). This paper will concentrate on results for the HSMP-386X series of diodes.

In Figure 5, the measured attenuation vs. frequency is given for several values of control voltage, with $V+$ set at 1.2V. Good performance is obtained over the frequency range of 3 MHz to 3 GHz. The slope observed at low control voltage levels is due to the internal capacitance of diodes D2 and D3. A lower insertion loss circuit is discussed in Appendix 1.

Figure 6 contains the plot of return loss vs. frequency at the maximum and minimum values of V_c . For all other values of V_c in between the return loss improves. In Figure 7, a plot is given for attenuation vs. control voltage at a number of frequencies. Finally, the intermodulation distortion performance of the attenuator is plotted in Figure 8.

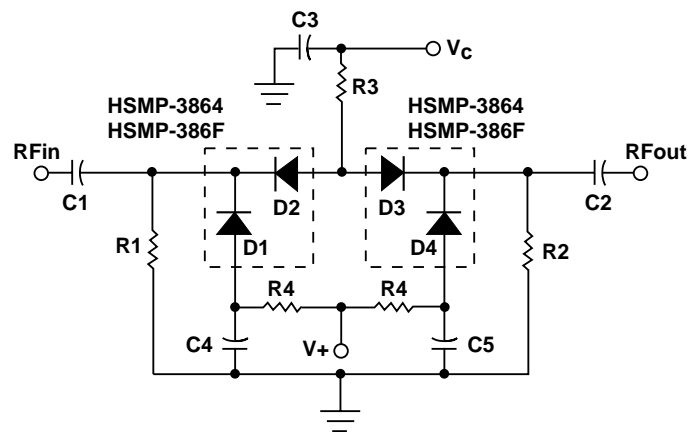

Figure 1. Wideband 4 Diode π Attenuator.

Component	Value	MFG/Part Number
R1, R2	620 Ω	RHOM/MCR10EZJH621
R3	390 Ω	RHOM/MCR10EZJH391
R4	2200 Ω	RHOM/MCR10EZJH222
C1-C5	10000 pF	AVX/CM05Y5V103Z50AB
D1-D4		Agilent/HSMP-3864/HSMP-386F

Table 1. Suggested Component Values for Wideband Attenuator.

General Assembly Information

The diodes and related components are assembled onto the printed circuit board as shown in Figure 4 and in the circuit diagram in Figure 1. The PIN Attenuator circuit board is designed to use edge-mounting SMA connectors such as Johnson Components, Inc., Model 142-0701-881. These connectors are designed to slip over the edge of 0.031-inch thick circuit boards and obviate the need to mount PCBs on a metal base plate for testing. The center conductors of the connectors are soldered to the input and output microstrip lines. The ground pins are soldered to the ground plane on the back of the board and to the top ground pads.

Conclusion

The data show that the HSMP-3864 and HSMP-386F surface mount, low cost, PIN diodes used in a four diode π attenuator circuit provides a very good match and flat attenuation over a very wide band. With an increasing use of wireless technology in portable equipment, small size can be a significant benefit, even an enabling characteristic. The active area of the on the new board is 20 x 15 mm (0.78 x 0.59 inches). The circuit is able to operate from a 5 Volt power supply a desirable attribute for integrated systems where common rail voltages are used. The benefits of lower control voltage and current consumption must be traded off against the lower distortion and the greater dynamic range of the HSMP-3814 and HSMP-381F series of diodes discussed in AN-1048.

Appendix 1— Lower Insertion Loss

R1 and R2 may be replaced by RF Chokes, a third RFC inserted between R3 and the circuit track, will lower the insertion loss considerably. The result of replacing the resistors is a reduction in operating bandwidth. Figure 3 shows a design using a combination of RF Chokes in series with R1, R2 and R3 which maybe used to reduce the insertion loss of the attenuator at minimum settings. Typically an insertion loss of 1.5 dB at 1900 MHz may be achieved on the evaluation board using the above circuit.

A Final Note on Performance

Actual performance of the HSMP-386F, HSMP-3864, HSMP-381F and HSMP-3814 mounted on the PIN Attenuator demonstration board may not exactly match data sheet specifications. The board material, passive components, and connectors all introduce losses and parasitics that may degrade device performance, especially at higher frequencies. Some variation in measured results is also to be expected as a result of the normal manufacturing distribution of products.

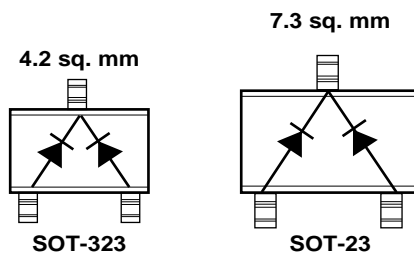

Figure 2. SOT-323 and SOT-23 Package Areas.

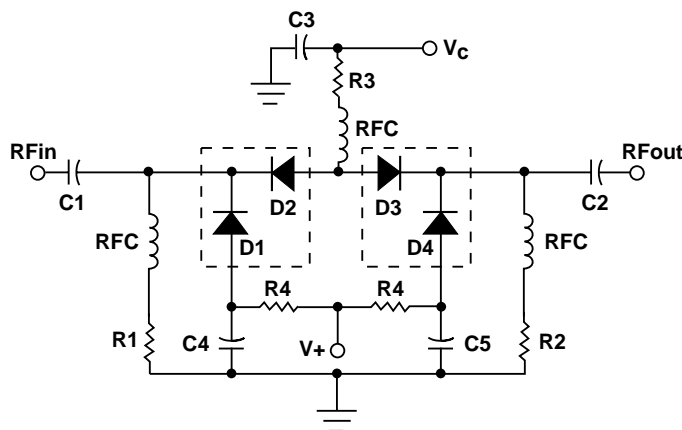

Figure 3. Low Insertion Loss 4 Diode π Attenuator.

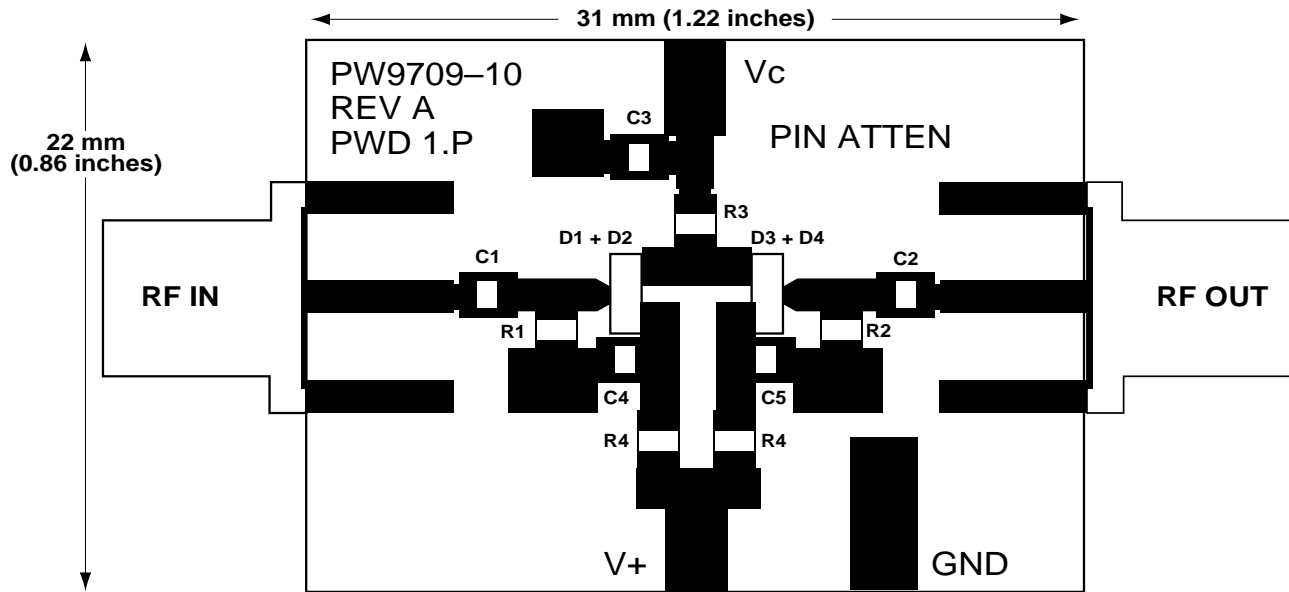

Figure 4. Circuit Board Layout.

HSMP-386F 4 Diode π Attenuator Typical Performance

$T_c = 25^\circ\text{C}$, $Z_o = 50\Omega$, $V_+ = 1.2\text{V}$

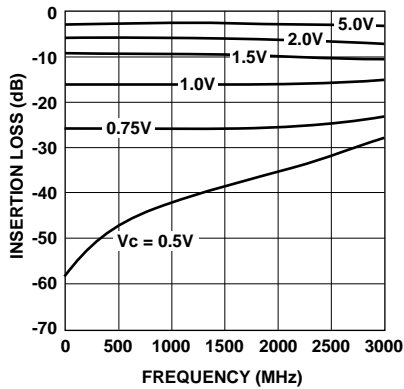

Figure 5. Attenuation vs. Frequency.

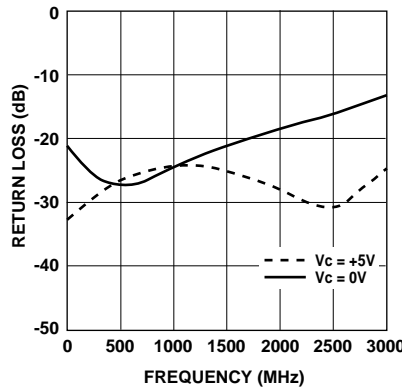

Figure 6. Return Loss vs. Frequency.

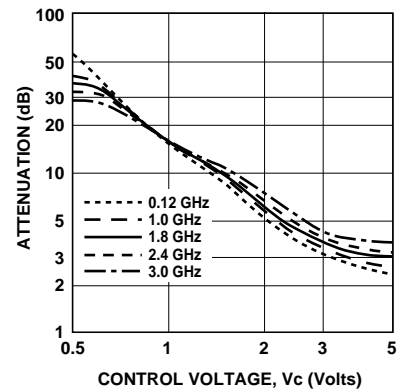

Figure 7. Attenuation vs. Control Voltage.

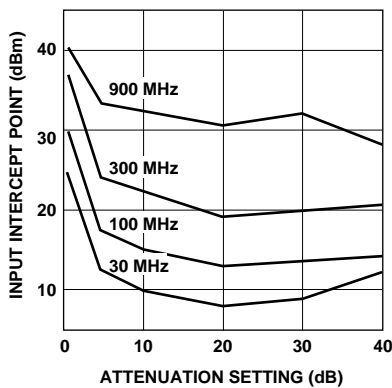

Figure 8. Input Intercept Point vs. Attenuation Setting.



Agilent Technologies

Innovating the HP Way

www.semiconductor.agilent.com

Data subject to change.

Copyright © 2000 Agilent Technologies, Inc.

Obsoletes 5965-1237E

5966-0449E (2/00)